

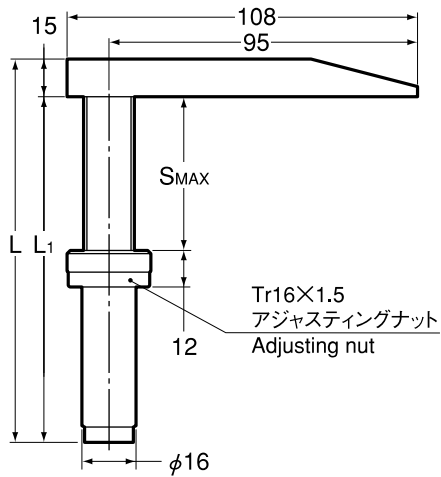

ゲージ PG  
Guage



商品コード Code	型式 Model	L	L1	SMAX	kg
0091 06000001	<b>PG-1</b>	128	113	50	0.4

ゲージスタンド PS  
Guage stand

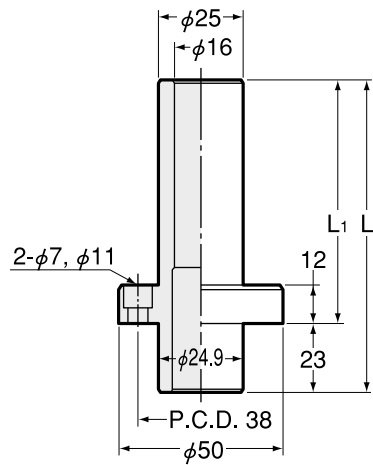

商品コード Code	型式 Model	L	L1
0091 01000001	<b>PS -1</b>	100	77
0091 01000002	<b>PS -2</b>	150	127
0091 01000003	<b>PS -3</b>	200	177
0091 01000004	<b>PS -4</b>	250	227
0091 01000005	<b>PS -5</b>	300	277

ホルダサポート PH-STC  
Holder support

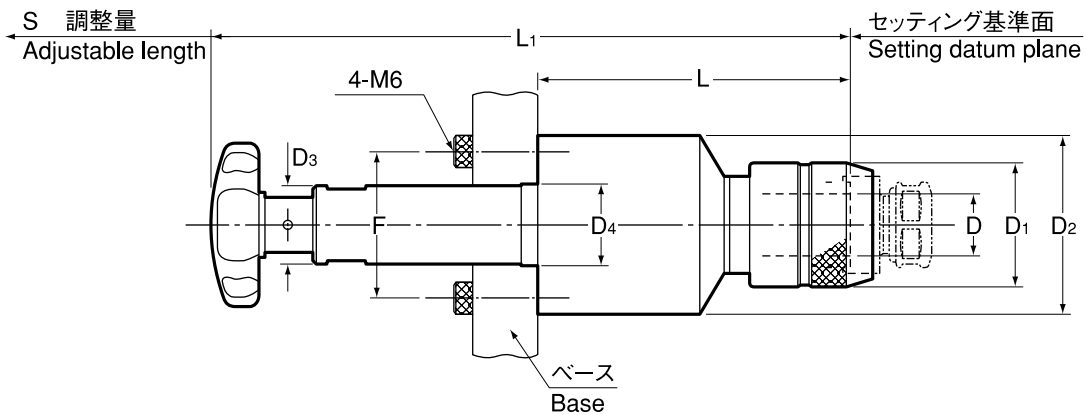

商品コード Code	型式 Model	D	D1	D2	D3	D4	L	L1	F	S	kg
0091 14000001	<b>PH -STC1</b>	19	38	55	24	25	98	200.5	45	45	1.5
0091 14000002	<b>PH -STC2</b>	31	55	55	24	25	118	220.5	45	45	1.9

ベース PBK  
Base

TYPE1

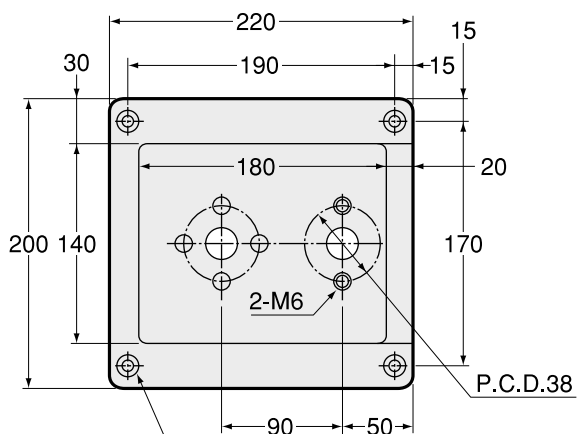

4-φ9 ザグリ φ14  
4-φ9 Counter boring φ14

TYPE2

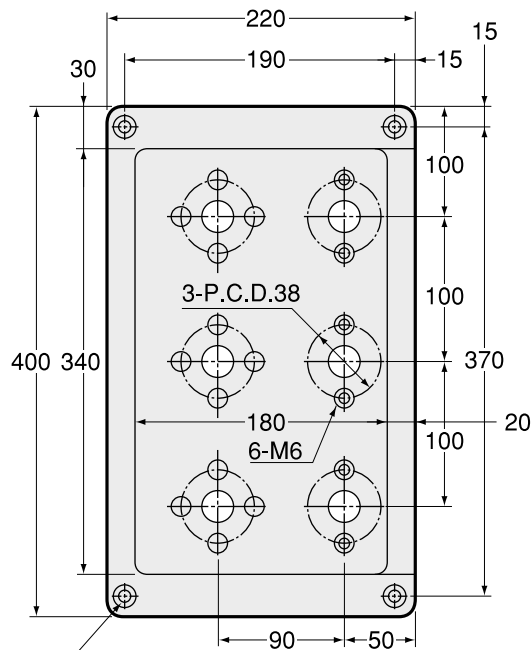

4-φ9 ザグリ φ14  
4-φ9 Counter boring φ14

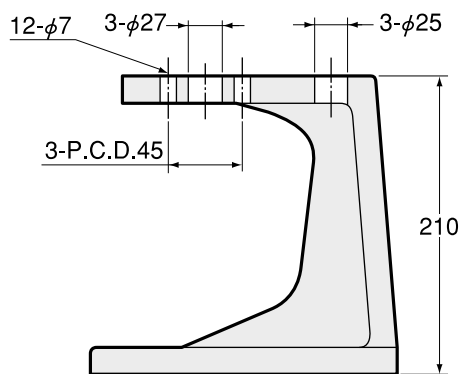
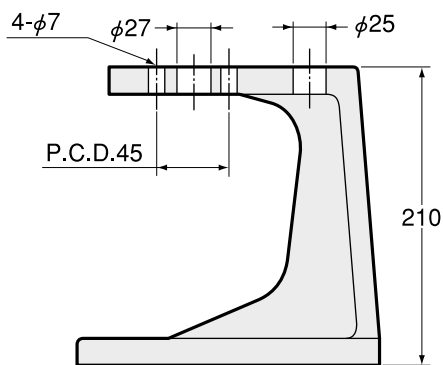

商品コード Code	型式 Model	タイプ Type	ホルダサポート Holder support	ゲージスタンド Gauge stand
0091 07100145	<b>PBK -1-45</b>	1	PH-STC1, PH-STC2	PS-1 ~ PS-5
0091 07100245	<b>PBK -2-45</b>	2	PH-STC1, PH-STC2	PS-1 ~ PS-5