



MaxLine Plus II 250GB AT Product Manual

October 30, 2003

Part Number: 1905



© October 30, 2003 Maxtor Corporation. All rights reserved. Printed in U.S.A.

This publication could include technical inaccuracies or typographical errors. Changes are periodically made to the information herein – which will be incorporated in revised editions of the publication. Maxtor may make changes or improvements in the product(s) described in this publication at any time and without notice.

UL/CSA/VDE/TUV

UL standard 1954 recognition granted under File No. E78016

CSA standard C22.2-950 certification granted under File No. LR49896

TUV Rheinland EN 60 950

Tested to FCC Rules for Radiated and Conducted Emissions, Part 15, Sub Part J, for Class-B Equipment.

PATENTS

These products are covered by or licensed under one or more of the following U.S. Patents:

4,419,701; 4, 538,193 4,625,109; 4,639,798; 4,647,769; 4,647,997; 4,661,696; 4,669,004; 4,675,652; 4,703,176; 4,730,321; 4,772,974; 4,783,705; 4,819,153; 4,882,671; 4,920,442; 4,920,434; 4,982,296; 5,005,089; 5,027,241; 5,031,061; 5,084,791; 5,119,254; 5,160,865; 5,170,229; 5,177,771; Other U.S. and Foreign Patents Pending.

Maxtor®, MaxFax® are registered trademarks of Maxtor Corporation, registered in the U.S.A. and other countries. Maxtor MaXLine Plus II 250GB AT, AutoTransfer, AutoRead, AutoWrite, DisCache, DiskWare, Defect Free Interface, and WriteCache are trademarks of Maxtor Corporation. All other brand names or trademarks are the property of their manufacturers.

Maxtor reserves the right to make changes and improvements to its products, without incurring any obligation to incorporate such changes or improvements into units previously sold or shipped.

This product or document is protected by copyright and distributed under licences restricting its use, copying, distributing, and decompilation. No part of this product or document may be reproduced in any form by any means without prior written authorization of Maxtor and its licensors, if any.

RESTRICTED RIGHTS LEGEND: Use, duplication, or disclosure by the government is subject to restrictions as set forth in subparagraphs (c)(1)(ii) of the Rights in Technical Data and Computer Software clause at DFARS 252.227-7013 and FAR 52.227-19.

THIS PUBLICATION IS PROVIDED "AS IS" WITHOUT WARRANTY OF ANY KIND, EITHER EXPRESS OR IMPLIED, INCLUDING, BUT NOT LIMITED TO, THE IMPLIED WARRANTIES OF MERCHANTABILITY, FITNESS FOR A PARTICULAR PURPOSE, OR NON-INFRINGEMENT.

You can request Maxtor publications from your Maxtor Sales Representative or order them directly from Maxtor.

Part Number: 1905

Corporate Headquarters:

**500 McCarthy Blvd.
Milpitas, California 95035
Tel: 408-894-5000
Fax: 408-362-4740**

Before You Begin

Thank you for your interest in Maxtor hard disk drives. This manual provides technical information for OEM engineers and systems integrators regarding the installation and use of Maxtor hard drives. Drive repair should be performed only at an authorized repair center. For repair information, contact the Maxtor Product Support Center at 1-800-2MAXTOR.

CAUTION: Maxtor hard drives are precision products. Failure to follow these precautions and guidelines outlined here may lead to product failure, damage and invalidation of all warranties.

- 1 **BEFORE** unpacking or handling a drive, take all proper electro-static discharge (ESD) precautions, including personnel and equipment grounding. Stand-alone drives are sensitive to ESD damage.
- 2 **BEFORE** removing drives from their packing material, allow them to reach room temperature.
- 3 During handling, **NEVER** drop, jar, or bump a drive.
- 4 Once a drive is removed from the Maxtor shipping container, **IMMEDIATELY** secure the drive through its mounting holes within a chassis. Otherwise, store the drive on a padded, grounded, antistatic surface.
- 5 **NEVER** switch DC power onto the drive by plugging an electrically live DC source cable into the drive's connector. **NEVER** connect a live bus to the drive's interface connector.
- 6 **ELECTRICAL GROUNDING** - For proper operation, the drive must be securely fastened to a device bay that provides a suitable electrical ground to the drive baseplate.

Please do not remove or cover up Maxtor factory-installed drive labels. They contain information required should the drive ever need repair. Thank you for your interest in Maxtor hard disk drives. This manual provides technical information for OEM engineers and systems integrators regarding the installation and use of Maxtor hard drives. Drive repair should be performed only at an authorized repair center. For repair information, contact the Maxtor Customer Service Center at 800-2MAXTOR or 1-303-678-2015.

Corporate Headquarters:

**500 McCarthy Blvd.
Milpitas, California 95035
Tel: 408-894-5000
Fax: 408-362-4740**

Table of Content

Chapter 1

INTRODUCTION

1.1 AUDIENCE	1-1
1.2 MANUAL ORGANIZATION	1-1
1.3 TERMINOLOGY AND CONVENTIONS	1-2
1.4 REFERENCES	1-3

Chapter 2

GENERAL DESCRIPTION

2.1 PRODUCT OVERVIEW	2-1
2.2 KEY FEATURES	2-2
2.3 REGULATORY COMPLIANCE STANDARDS	2-3
2.4 HARDWARE REQUIREMENTS	2-4

Chapter 3

INSTALLATION

3.1 SPACE REQUIREMENTS	3-1
3.2 UNPACKING INSTRUCTIONS	3-2
3.3 HARDWARE OPTIONS	3-5
3.3.1 ATA Interface Connector	3-5
3.3.2 ATA BUS ADAPTER	3-9
3.4 COMBINATION CONNECTOR (J1)	3-9
3.4.1 DC Power (J1, Section A)	3-11
3.4.2 External Drive Activity LED	3-11
3.4.3 ATA Bus Interface Connector (J1, Section C)	3-11
3.4.4 SATA (Serial ATA) Interface Connector	3-12
3.4.5 SATA BUS ADAPTER	3-12
3.5 COMBINATION CONNECTOR (J1)	3-13
3.5.1 DC Power (J1, Section A)	3-14
3.5.2 ATA Bus Interface Connector (J1, Section C)	3-16
3.6 MOUNTING	3-17
3.6.1 Orientation	3-17
3.6.2 Clearance	3-19
3.6.3 Ventilation	3-19
3.7 FOR SYSTEMS WITH A MOTHERBOARD ATA/SATA ADAPTER	3-20
3.8 FOR SYSTEMS WITH AN ATA ADAPTER BOARD	3-20

3.8.1 Adapter Board Installation	3-20
3.9 TECHNIQUES IN DRIVE CONFIGURATION.....	3-23
3.9.1 The 528-Megabytes Barrier	3-23
3.9.2 The 8.4-Gigabytes Barrier	3-23
3.9.3 Operating system limitations	3-24
3.10 SYSTEM STARTUP AND OPERATION.....	3-24

Chapter 4

PRODUCT SPECIFICATIONS

4.1 Models and Capacities.....	4-1
4.2 Drive Configuration	4-1
4.3 Performance Specifications.....	4-2
4.4 Physical Dimensions	4-3
4.5 Power Requirements.....	4-3
4.6 Power Mode Definitions	4-4
4.7 EPA Energy Star Compliance	4-4
4.8 Environmental Limits.....	4-5
4.9 Shock and Vibration.....	4-6
4.10 Reliability Specifications	4-7
4.11 EMC/EMI.....	4-8
4.11.1 Radiated Electromagnetic Field Emissions - EMC Compliance	4-8
4.11.2 Canadian Emissions Statement	4-8
4.12 Safety Regulatory Compliance.....	4-8

Chapter 5

ATA BUS INTERFACE AND ATA COMMANDS

5.1 INTRODUCTION.....	5-1
5.2 MECHANICAL INTERFACE	5-1
5.2.1 Signal Cable and Connector	5-1
5.3 ELECTRICAL INTERFACE.....	5-1
5.3.1 ATA Bus Interface	5-1
5.4 REGISTER ADDRESS DECODING.....	5-2
5.5 COMMAND INTERFACE.....	5-2
5.5.1 General Feature Set	5-2
5.5.2 Supported Commands	5-2

Chapter 6

SERVICE AND SUPPORT

6.1 Product Support/Technical Assistance/Customer Service	6-1
---	-----

Appendix A

BREAKING THE 137 GIGABYTE STORAGE BARRIER

A.1 Breaking the 137 Gigabyte Storage Barrier.....	A-1
A.1.1 History	A-1
A.1.2 Solving the 137 Gigabyte Capacity Barrier	A-3
A.1.3 How is the Extension Implemented?	A-3
A.1.4 What Do the Drives Need to Meet the Spec?	A-3
A.1.5 What Else is Involved?	A-3
A.1.6 What is the Next Barrier?	A-4

List of Figures

Figure 3-1	Mechanical Dimensions of Maxtor DiamondMax Plus9 Hard Disk Drive	3-1
Figure 3-2	Single-Pack Shipping Container	3-3
Figure 3-3	20-Pack Shipping Container	3-4
Figure 3-4	Jumper Locations on the ATA Interface Connector	3-5
Figure 3-5	AT Connector and Jumper Location	3-8
Figure 3-6	J1 DC Power and ATA Bus Combination Connector	3-10
Figure 3-7	The SATA Interface Connector	3-12
Figure 3-8	Serial ATA PCB	3-13
Figure 3-9	Mounting Dimensions for the Maxtor DiamondMax Plus9 Hard Disk Drives	3-17
Figure 3-10	Mounting Screw Clearance for the Maxtor Hard Disk Drives	3-18
Figure 3-11	Drive Power Supply and ATA Bus Interface Cables	3-21
Figure 3-12	Completing the Drive Installation	3-22

List of Tables

Table 3-1	AT Jumper Options	3-6
Table 3-2	J1 Power Connector, Section A	3-11
Table 3-3	J1 Power Connector, Section A	3-14
Table 3-4	Device plug connector pin definition.....	3-15
Table 3-5	Logical Addressing Format.....	3-25
Table 5-1	Supported Commands	5-2
Table 5-2	Identify Drive Command Parameters.....	5-5

Chapter 1 Introduction

This chapter gives an overview of the contents of this manual, including the intended audience, how the manual is organized, terminology and conventions, and references.

1.1 AUDIENCE

The MaXLine Plus II 250GB AT Product Manual is intended for several audiences. These audiences include: the end user, installer, developer, consumer electronics and personal computer original equipment manufacturer (CE/PC OEM), and distributor. The manual provides information about installation, principles of operation, interface command implementation, and maintenance.

The MaXLine Plus II 250GB AT family of drives provide a high-quality, low-cost, market leading 80 GB per disk products to serve the consumer and mainstream commercial markets, as well as the consumer electronics market.

1.2 MANUAL ORGANIZATION

This manual is organized into the following chapters:

- Chapter 1 – *Introduction*
- Chapter 2 – *General Description*
- Chapter 3 – *Installation*
- Chapter 4 – *Product Specifications*
- Chapter 5 – *ATA Bus Interface and ATA Commands*
- Chapter 6 – *Service and Support*
- Appendix A – *Breaking the 137-Gigabyte Storage Barrier*

1.3 **TERMINOLOGY AND CONVENTIONS**

In the Glossary at the back of this manual, you can find definitions for many of the terms used in this manual. In addition, the following abbreviations are used in this manual:

- ASIC Application-Specific Integrated Circuit
- ATA Advanced Technology Attachment
- bpi bits per inch
- DA Double Amplitude(represents pk-pk shaker displacement)
- dB decibels
- dBA decibels, A weighted
- DPS Data Protection System
- SPS Shock Protection System
- ECC Error Correcting Code
- Kfci thousands of flux changes per inch
- Hz Hertz
- KB Kilobytes
- LSB Least Significant Bit
- mA milliamperes
- MB Megabytes (1 MB = 1,000,000 bytes when referring to disk transfer rates or storage capacities and 1,048,576 bytes in all other cases)
- Mb/s Megabits per second
- MB/s Megabytes per second
- MHz Megahertz
- ms milliseconds
- MSB Most Significant Bit
- mV millivolts
- ns nanoseconds
- SATA Serial ATA Interface
- tpi tracks per inch
- μ s microseconds
- V Volts

The typographical and naming conventions used in this manual are listed below. Conventions that are unique to a specific table appear in the notes that follow that table.

Typographical Conventions:

- **Names of Bits:** Bit names are presented in initial capitals. An example is the Host Software Reset bit.
- **Commands:** Interface commands are listed in all capitals. An example is WRITE LONG.
- **Register Names:** Registers are given in this manual with initial capitals. An example is the Alternate Status Register.
- **Parameters:** Parameters are given as initial capitals when spelled out, and are given as all capitals when abbreviated. Examples are Prefetch Enable (PE), and Cache Enable (CE).
- **Hexadecimal Notation:** The hexadecimal notation is given in 9-point subscript form. An example is 30_H.
- **Signal Negation:** A signal name that is defined as active low is listed with a minus sign following the signal. An example is RD₋.
- **Messages:** A message that is sent from the drive to the host is listed in all capitals. An example is ILLEGAL COMMAND.

Naming Conventions:

- **Host:** In general, the system in which the drive resides is referred to as the host.
- **Computer Voice:** This refers to items you type at the computer keyboard. These items are listed in 10-point, all capitals, Courier font. An example is FORMAT C:/S.

1.4 REFERENCES

For additional information about the ATA interface, refer to the latest revision of the draft standard on the internet at <http://www.t13.org/> using the link under "1410D AT Attachment - 6 with Packet Interface (ATA/ATAPI - 6)."

Chapter 2

GENERAL DESCRIPTION

This chapter summarizes the general functions and key features of the MaxLine Plus II 250GB hard disk drive, as well as the applicable standards and regulations.

2.1 PRODUCT OVERVIEW

Maxtor's MaxLine Plus II 250GB hard disk drive is part of a family of high performance, 1-inch-high hard disk drives manufactured to meet the highest product quality standards.

These hard disk drives use nonremovable, 3 1/2-inch hard disks and are available with the ATA interface.

The MaxLine Plus II 250GB hard disk drive features an embedded hard disk drive controller, and use ATA commands to optimize system performance. Because the drive manages media defects and error recovery internally, these operations are fully transparent to the user.

The innovative design of the MaxLine Plus II 250 GB hard disk drive incorporate leading edge technologies such as Ultra ATA/133, Serial ATA Option with transfer speeds up to 150 MB/second, Advanced Cache Management, Shock Protection System™ (SPS), Data Protection System (DPS) and Quiet Drive Technology (QDT). These enhanced technologies enable Maxtor to produce a family of high-performance, high-reliability drives.

2.2 KEY FEATURES

The MaXLine Plus II 250GB AT hard disk drive includes the following key features:

General

- Low profile, 1-inch height
- Industry standard 3 1/2-inch form factor
- Emulation of IBM® PC AT® task file register, and all AT fixed disk commands
- Windows NT and 9X Certification

Performance

- Average seek time of <9.0 ms
- Average rotational latency of 4.17 ms
- New Ultra ATA interface with Maxtor-patented Ultra ATA/133 protocol supporting burst data transfer rates of 133MB/s
- Serial ATA interface with transfer speeds up to 150MB per second
- 8MB Cache buffer with 1.9MB (approximate) Advance Cache Management (ACM)
- Look-ahead DisCache feature with continuous prefetch and WriteCache write-buffering capabilities
- AutoTask Register update, Multi-block AutoRead, and Multi-block AutoWrite features in a custom ASIC
- Read-on-arrival firmware
- Quadruple-burst ECC, and double burst ECC on-the-fly
- 1:1 interleave on read/write operations
- Support of all standard ATA data transfer modes with PIO mode 4 and multiword DMA mode 2, and Ultra DMA modes 0, 1, 2, 3, 4, 5 and 6
- Adaptive cache segmentation
- 100% FDB (Fluid Dynamic Bearing Motors)

Reliability

- Exceeds one million hours mean time expected until the first failure (MTTF)
- Automatic retry on read errors
- 320-bit, non-interleaved Reed-Solomon Error Correcting Code (ECC), with cross checking correction up to fifteen separate bursts of 10 bits each totalling up to 150 bits in length
- S.M.A.R.T. 4 (Self-Monitoring, Analysis and Reporting Technology)
- Transparent media defect mapping
- High performance, in-line defective sector skipping
- Reassignment of defective sectors discovered in the field, without reformatting
- Shock Protection System to reduce handling induced failures
- Data Protection System to verify drive integrity
- Quiet Drive Technology (QDT)

Versatility

- Power saving modes
- Downloadable firmware
- Cable select feature
- Ability to daisy-chain two drives on the interface

2.3 REGULATORY COMPLIANCE STANDARDS

Maxtor Corporation's disk drive products meet all domestic and international product safety regulatory compliance requirements. Maxtor's disk drive products conform to the following specifically marked Product Safety Standards:

- Underwriters Laboratories (UL) Standard 1950. This certificate is a category certification pertaining to all 3.5-inch series drives models.
- Canadian Standards Association (CSA) Standard C.22.2 No. 1950. This certificate is a category certification pertaining to all 3.5-inch series drives models.
- TUV Rheinland Standard EN60 950. This certificate is a category certification pertaining to all 3.5-inch series drives models.

Product EMI/EMS Qualifications:

- CE Mark authorization is granted by TUV Rheinland in compliance with our qualifying under EN 55022:1994 and EN 50082-1:1997.
- C-Tick Mark is an Australian authorization marked noted on Maxtor's disk drive products. The mark proves conformity to the regulatory compliance document AS/NZS 3548: 1995 and BS EN 55022: 1995.
- Maxtor's disk drives are designed as a separate subassembly that conforms to the FCC Rules for Radiated and Conducted emissions, Part 15 Subpart J; Class B when installed in a given computer system.
- Approval from Taiwan BSMI. Number: 3892A638

2.4 HARDWARE REQUIREMENTS

The MaXLine Plus II 250GB AT hard disk drive is compatible with the IBM PC AT, and other computers that are compatible with the IBM PC AT. It connects to the PC either by means of a third-party IDE-compatible adapter board, or by plugging a cable from the drive directly into a PC motherboard that supplies an ATA interface.

Chapter 3 INSTALLATION

This chapter explains how to unpack, configure, mount, and connect the Maxtor MaXLine Plus II 250 GB AT hard disk drive prior to operation. It also explains how to start up and operate the drive.

3.1 SPACE REQUIREMENTS

The MaXLine Plus II 250GB AT hard disk drives are shipped without a faceplate.

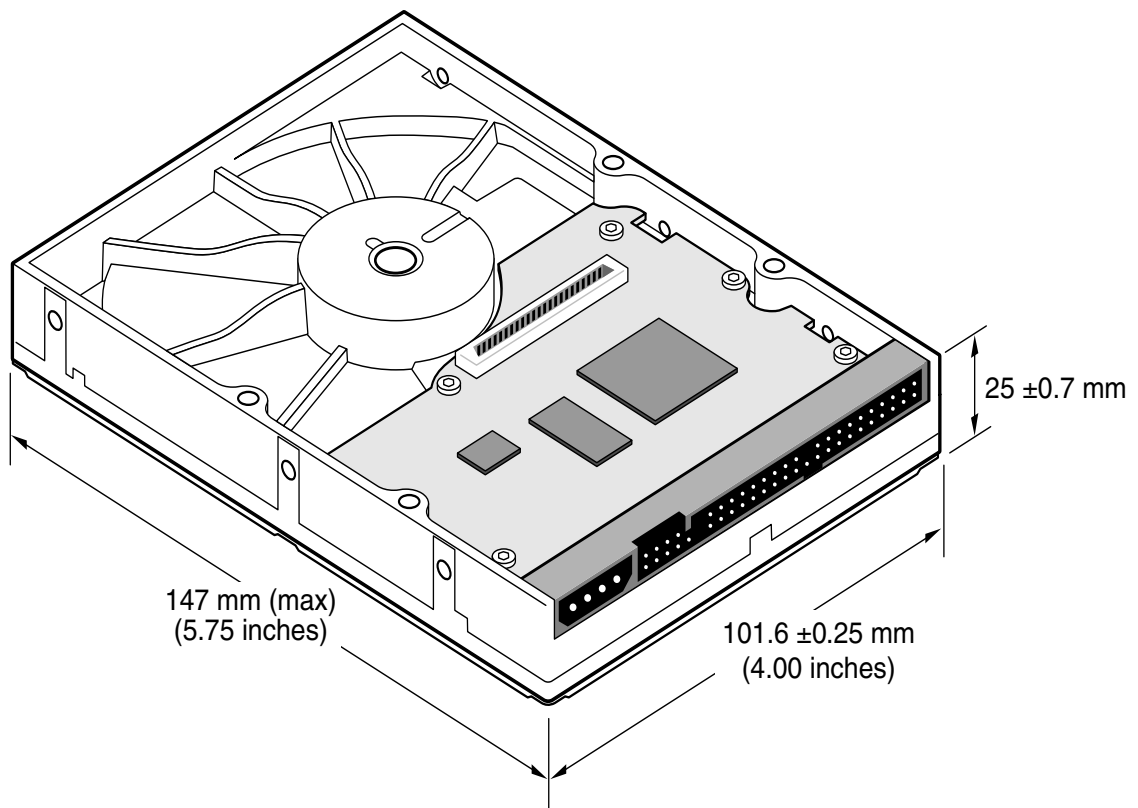

Figure 3-1 shows the external dimensions of the MaXLine Plus II 250GB AT drives.

Figure 3-1 Mechanical Dimensions of MaXLine Plus II 250GB AT Hard Disk Drive

3.2 UNPACKING INSTRUCTIONS

CAUTION: The maximum limits for physical shock can be exceeded if the drive is not handled properly. Special care should be taken not to bump or drop the drive. It is highly recommended that MaXLine Plus II 250GB at drives are not stacked or placed on any hard surface after they are unpacked. Such handling could cause media damage.

1. Open the shipping container and remove the packing assembly that contains the drive.
2. Remove the drive from the packing assembly.

CAUTION: During shipment and handling, the antistatic electrostatic discharge (ESD) bag prevents electronic component damage due to electrostatic discharge. To avoid accidental damage to the drive, do not use a sharp instrument to open the ESD bag and do not touch PCB components. Save the packing materials for possible future use.

3. When you are ready to install the drive, remove it from the ESD bag.

Figure 3-2 shows the packing assembly for a single Maxtor MaXLine Plus II 250GB AT hard disk drive. A 20-pack shipping container is available for multiple drive shipments.

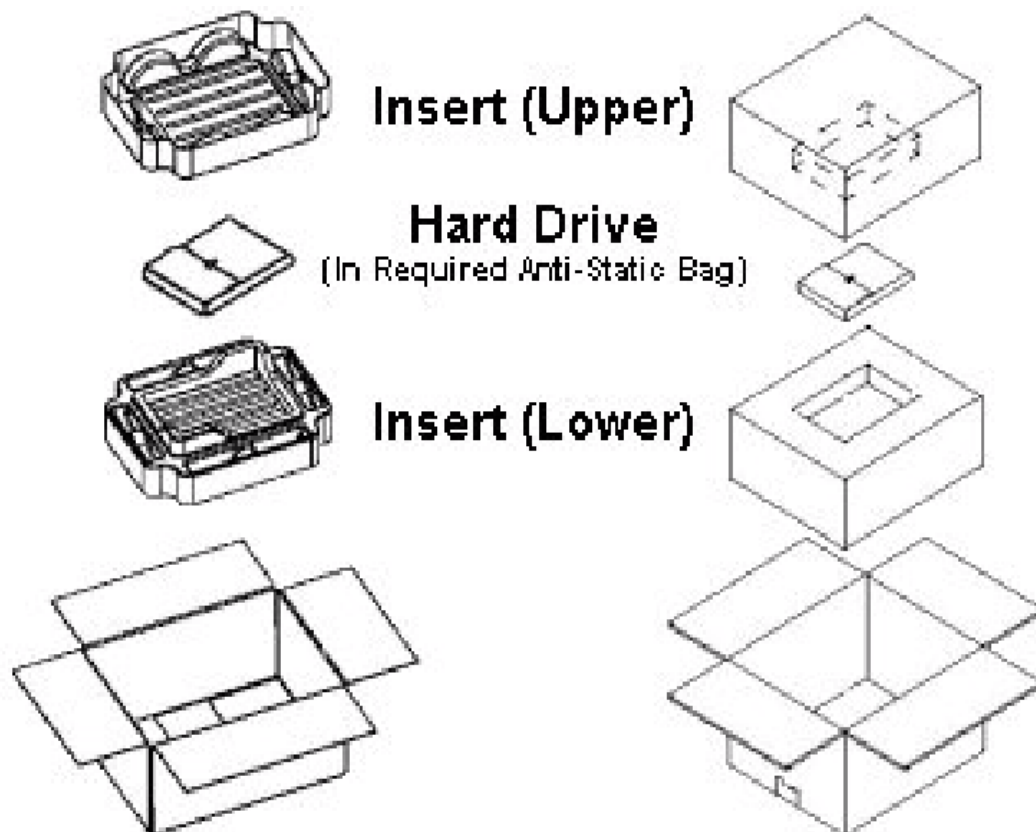
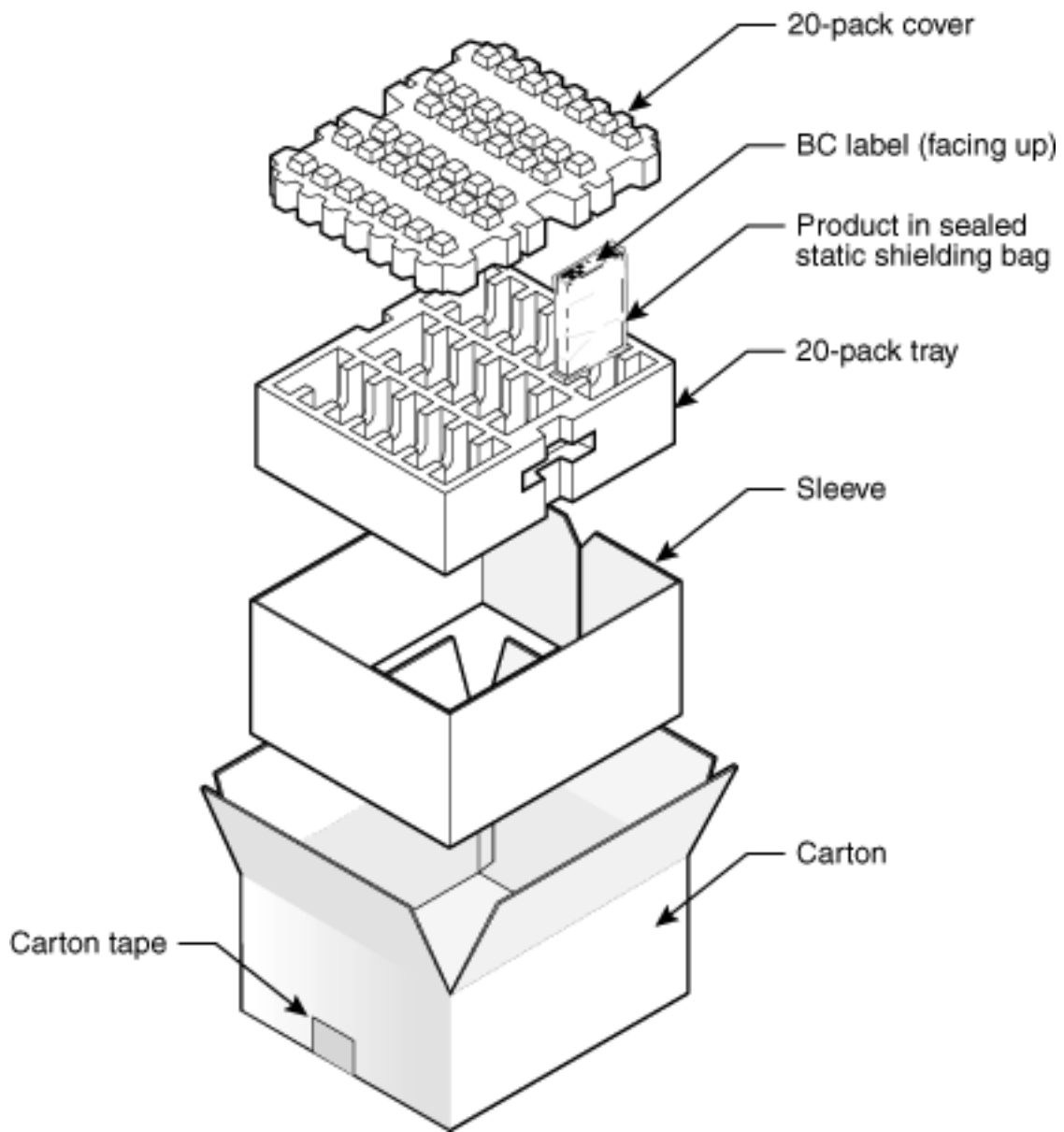

Figure 3-2 Single-Pack Shipping Container

Figure 3-3 20-Pack Shipping Container



3.3 HARDWARE OPTIONS

3.3.1 ATA Interface Connector

The configuration of a MaXLine Plus II 250GB AT hard disk drive depends on the host system in which it is to be installed. This section describes the hardware options that you must take into account prior to installation.

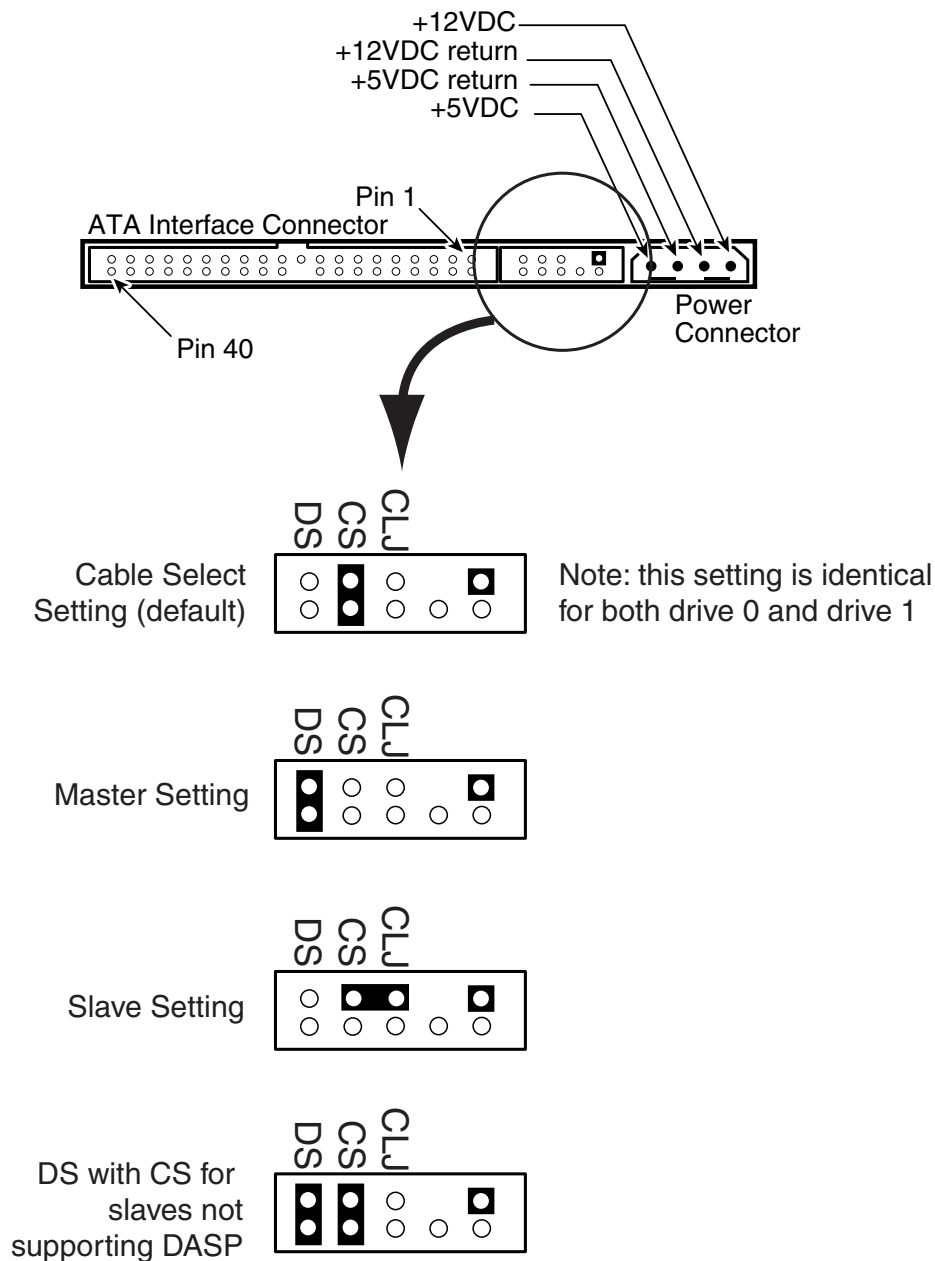

Figure 3-4 Jumper Locations on the ATA Interface Connector

The configuration of the following three jumpers controls the drive's five modes of operation:

- CS – Cable Select
- DS – Drive Select
- CLJ– Cylinder Limitation Jumper

The AT PCB has two jumper locations provided to configure the drive in a system. The default configuration for the drive as shipped from the factory is with a jumper across the CS location, and open positions in the DS and CLJ positions.

Table 3-1 defines the operation of the master/slave jumpers and their function relative to pin 28 on the interface. *1* indicates that the specified jumper is installed; *0* indicates that the jumper is not installed.

Table 3-1 AT Jumper Options

CS	DS	PIN 28	DESCRIPTION
0	0	X	Drive is configured as a slave
1	0	Gnd	Drive is configured as Master (Device 0) when attached to the end of a 80 conductor Ultra ATA cable
0	1	X	Drive is configured as a Master
1	0	Open	Drive is configured as a Slave (Device 1) when attached to the middle of a 80 conductor Ultra ATA cable
1	1	X	Drive is configured as a Master with an attached slave that does not support DASP

Note: In Table 3-1, a *0* indicates that the jumper is removed, a *1* indicates that the jumper is installed, and an X indicates that the jumper setting does not matter.

3.3.1.1 Cable Select (CS) Jumper

When a MaXLine Plus II 250GB AT hard disk drive and another ATA hard disk drive are daisy-chained together, they can be configured as Master or Slave either by the CS or DS jumpers. To configure the drive as a Master or Slave with the CS feature, the CS jumper is installed (1). The drive's position on the 80 conductor Ultra ATA data cable then determines whether the drive is a Master (Device 0) or a Slave (Device 1). If the drive is connected to the end of the Ultra (cable Select) data cable the drive is a Master. If the drive is connected to the middle connection it is set as a Slave.

Once you install the CS jumper, the drive is configured as a Master or Slave by the state of the Cable Select signal: pin 28 of the ATA bus connector. Please note that pin 28 is a vendor-specific pin that Maxtor is using for a specific purpose. More than one function is allocated to CS, according to the ATA CAM specification (see reference to this specification in Chapter 1). If pin 28 is a *0* (grounded), the drive is configured as a Master. If it is a *1* (high), the drive is configured as a Slave. In order to configure two drives in a Master/Slave relationship using the CS jumper, you need to use a cable that provides the proper signal level at pin 28 of the ATA bus connector. This allows two drives to operate in a Master/Slave relationship according to the drive cable placement.

The MaXLine Plus II 250GB AT hard disk drives are shipped from the factory as a Master (Device 0 - CS jumper installed). To configure a drive as a Slave (Device 1-DS scheme), the CS jumper must be removed. In this configuration, the spare jumper removed from the CS position may be stored on the PK jumper pins.

3.3.1.2 Drive Select (DS) Jumper

You can also daisy-chain two drives on the ATA bus interface by using their Drive Select (DS) jumpers. To use the DS feature, the CS jumper must not be installed.

To configure a drive as the Master (Device 0), a jumper must be installed on the DS pins.

Note: The order in which drives are connected in a daisy chain has no significance.

3.3.1.3 Master Jumper Configuration

In combination with the current DS or CS jumper settings, the Slave Present (SP) jumper can be implemented if necessary as follows:

Note: The CS position doubles as the Slave present on this drive.

When the drive is configured as a Master (DS jumper installed or CS jumper installed, and the Cable Select signal is set to (0), adding an additional jumper (both jumpers DS and CS now installed) will indicate to the drive that a Slave drive is present. This Master with Slave Present jumper configuration should be installed on the Master drive only if the Slave drive does not use the Drive Active/Slave Present (DASP-) signal to indicate its presence.

3.3.1.4 Cylinder Limitation Jumper (CLJ)

For user capacities below 66,055,248 sectors (32GB), inserting the CLJ jumper limits the Number of Cylinders field 1 to a value of 16,383, as reported in IDENTIFY DEVICE data word. This allows software drivers to determine that the actual capacity is larger than indicated by the maximum CHS, requiring LBA addressing to use the full capacity.

A summary of these effects for the Maxtor MaXLine Plus II 250GB AT drives is shown in the following table:

	CLJ JUMPER OUT
250GB	C = 16,383 H = 16 S = 63 LBA = 490,234,752

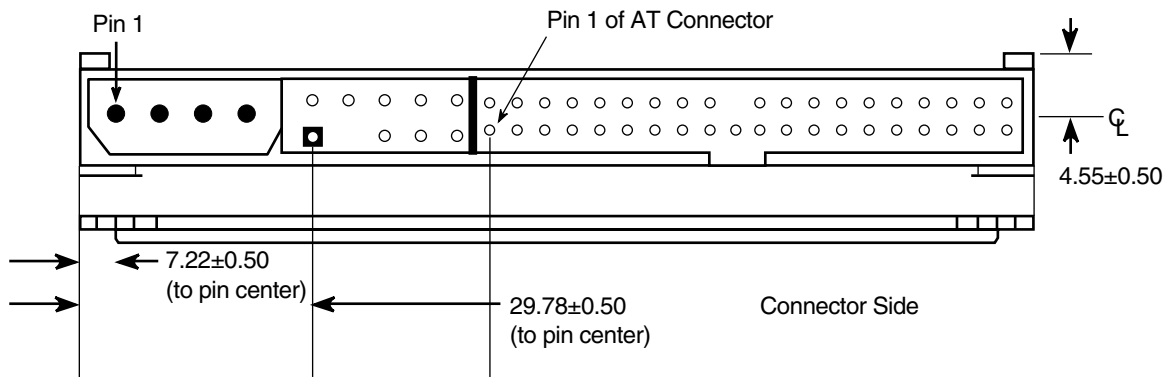

Figure 3-5 AT Connector and Jumper Location

3.3.2 ATA BUS ADAPTER

There are two ways you can configure a system to allow the MaXLine Plus II 250GB AT hard disk drives to communicate over the ATA bus of an IBM or IBM-compatible PC:

1. Connect the drive to a 40-pin ATA bus connector (if available) on the motherboard of the PC.
2. Install an IDE-compatible adapter board in the PC, and connect the drive to the adapter board.

This board is available at Maxtor (p/n: K01PCAT133).

3.3.2.1 40-Pin ATA Bus Connector

Most PC motherboards have a built-in 40-pin ATA bus connector that is compatible with the 40-pin ATA interface of the MaXLine Plus II 250GB AT hard disk drives. If the motherboard has an ATA connector, simply connect a 40-pin ribbon cable between the drive and the motherboard.

You should also refer to the motherboard instruction manual to ensure signal compatibility.

3.3.2.2 Adapter Board

If your PC motherboard does not contain a built-in 40-pin ATA bus interface connector, you must install an ATA bus adapter board and connecting cable to allow the drive to interface with the motherboard. Maxtor does supply such an adapter board.

Please carefully read the instruction manual that comes with your adapter board, as well as Chapter 6 of this manual to ensure signal compatibility between the adapter board and the drive. Also, make sure that the adapter board jumper settings are appropriate.

3.4 COMBINATION CONNECTOR (J1)

J1 is a three-in-one combination connector. The drive's DC power can be applied to section A. The ATA bus interface (40-pin) uses section C. The connector is mounted on the back edge of the printed-circuit board (PCB), as shown in Figure 3-6.

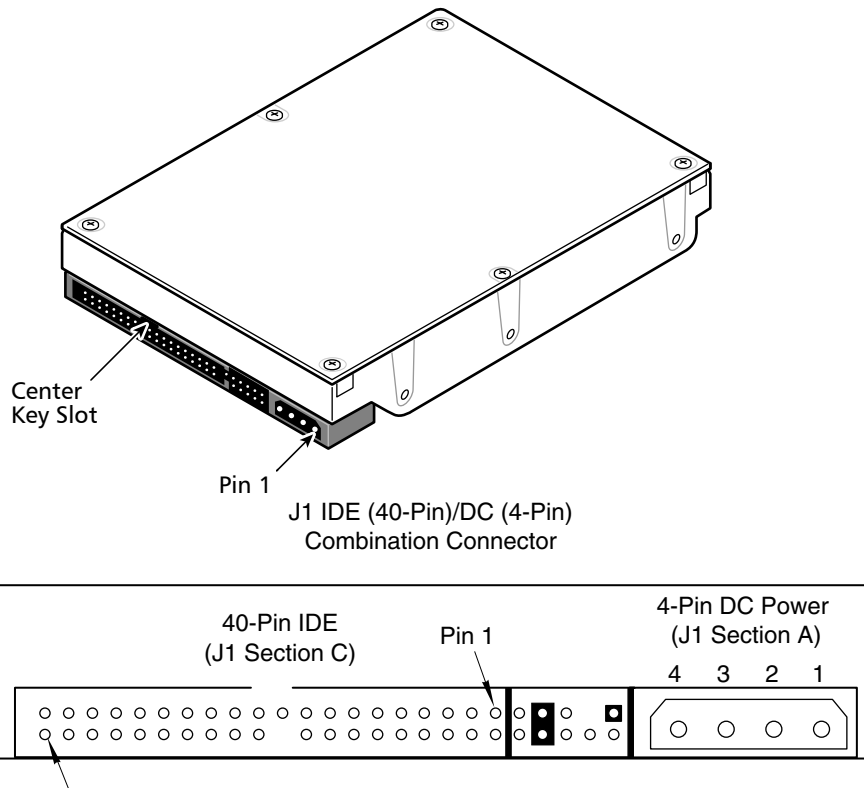

Figure 3-6 J1 DC Power and ATA Bus Combination Connector

3.4.1 DC Power (J1, Section A)

The recommended mating connectors for the +5 VDC and +12 VDC input power are listed in Table 3-2.

Table 3-2 J1 Power Connector, Section A

PIN NUMBER	VOLTAGE LEVEL	MATING CONNECTOR TYPE AND PART NUMBER (OR EQUIVALENT)
J1 Section A (4-Pin):		
1	+ 12 VDC	4-Pin Connector: AMP P/N 1-480424-0 Loose piece contacts: AMP P/N VS 60619-4 Strip contacts: AMP P/N VS 61117-4
2	Ground Return for + 12 VDC	
3	Ground Return for + 5 VDC	
4	+ 5 VDC	

Note: Labels indicate the pin numbers on the connector. Pins 2 and 3 of section A are the +5 and +12 volt returns and are connected together on the drive.

3.4.2 External Drive Activity LED

An external drive activity LED may be connected to the DASP-I/O pin 39 on J1. For more details, see the pin description in Table 6-1.

3.4.3 ATA Bus Interface Connector (J1, Section C)

On the MaXLine Plus II 250GB AT hard disk drives, the ATA bus interface cable connector (J1, section C) is a 40-pin Universal Header, as shown in Figure 3-6.

To prevent the possibility of incorrect installation, the connector has been keyed by removing Pin 20. This ensures that a connector cannot be installed upside down.

See Chapter 5, “ATA Bus Interface and ATA Commands,” for more detailed information about the required signals. Refer to Table 5-1 for the pin assignments of the ATA bus connector (J1, section C).

3.4.4 SATA (Serial ATA) Interface Connector

The MaXLine Plus II 250GB AT hard disk drives also offer an optional Serial ATA interface. SATA has no user changeable configuration jumpers. All configurations are controlled in the SATA interface by the host.

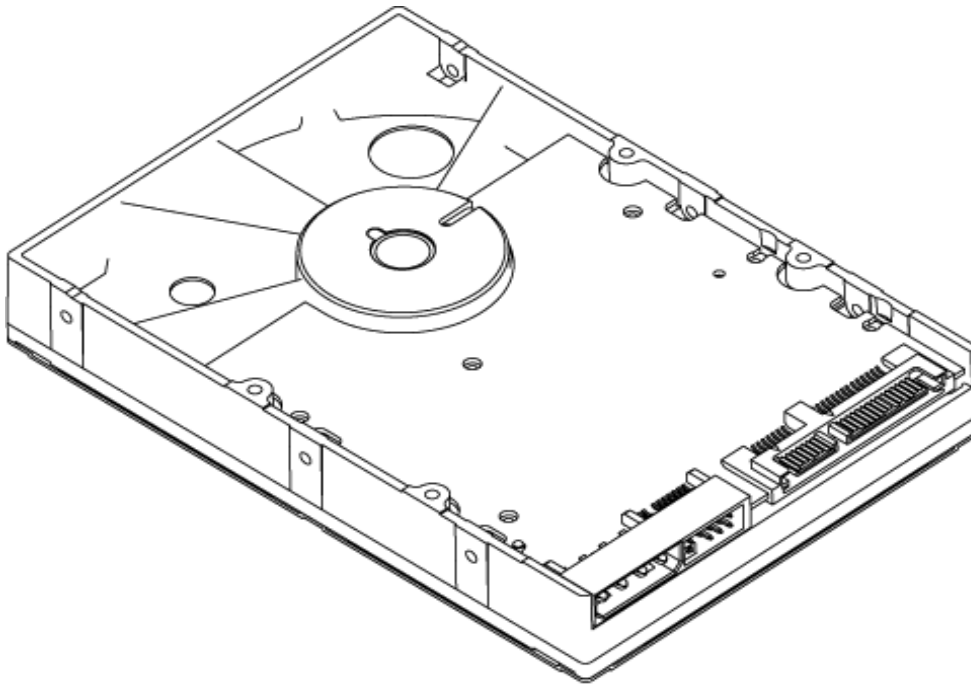

Figure 3-7 The SATA Interface Connector

3.4.5 SATA BUS ADAPTER

There are two ways you can configure a system to allow the MaXLine Plus II 250GB AT hard disk drives to communicate over the SATA bus of an IBM or IBM-compatible PC:

1. Connect the drive to a SATA bus connector (if available) on the motherboard of the PC.
2. Install an IDE-compatible adapter board in the PC, and connect the drive to the adapter board.

3.4.5.1 SATA Bus Connector

Some PC motherboards have a built in SATA bus connector. These SATA bus connectors are compatible with Maxtor MaXLine Plus II 250GB AT hard disk drives. If the motherboard has a SATA connector, simply connect a 7 pin SATA cable between the drive and the motherboard.

3.4.5.2 Adapter Board

If your PC motherboard does not contain a built-in SATA bus interface connector, you must install an SATA bus adapter board and connecting cable to allow the drive to interface with the motherboard. Maxtor does not supply such an adapter board, but they are available from several third-party vendors.

Please carefully read the instruction manual that comes with your adapter board to ensure signal compatibility between the adapter board and the drive. Also, make sure that the adapter board jumper settings are appropriate.

3.5 COMBINATION CONNECTOR (J1)

J1 is a three-in-one combination connector. The drive's DC power can be applied to section A or B. Do not connect both a and b to power at the same time. The SATA interface (7-pin) uses section C. The connector is mounted on the back edge of the printed-circuit board (PCB), as shown in Figure 3-6.

CAUTION: Do not connect both a and b to power at the same time

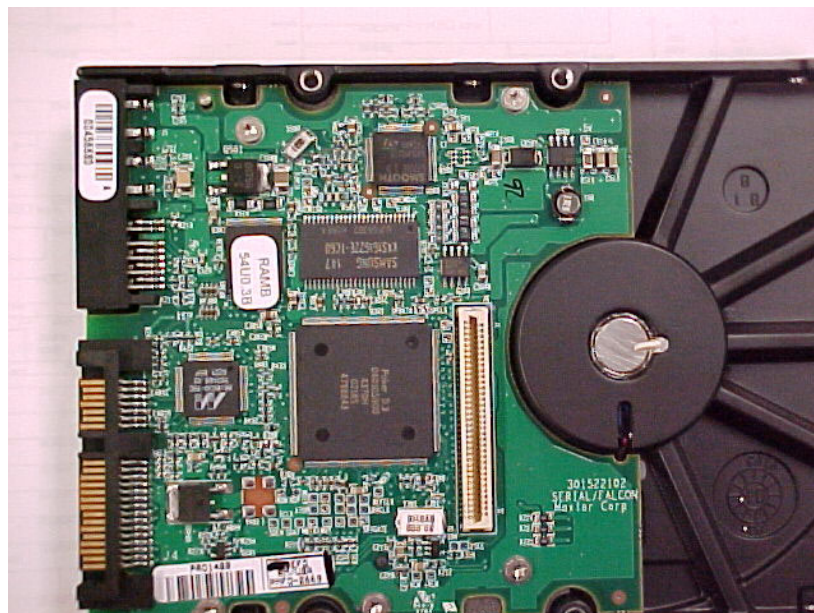

Figure 3-8 Serial ATA PCB

There are total of 7 pins in the signal segment and 15 pins in the power segment. The pin definitions are shown in Table 3-3. Note that the pin is numbered from the pin furthest from the power segment.

Table 3-3 Device plug connector pin definition

Signal segment	S1	Ground	2 nd Mate
	S2	A +	Differential signal pair A from Phy
	S3	A-	
	S4	Ground	2 nd Mate
	S5	B-	Differential signal pair B from Phy
	S6	B +	
	S7	Ground	2 nd Mate
Key and spacing separate signal and power segments			
Power segment	P1	V ₃₃	3.3V power
	P2	V ₃₃	3.3V power
	P3	V ₃₃	3.3V power, pre-charge, 2 nd mate
	P4	Ground	1 st mate
	P5	Ground	2 nd mate
	P6	Ground	2 nd mate
	P7	V ₅	5V power, pre-charge, 2 nd mate
	P8	V ₅	5V power
	P9	V ₅	5V power
	P10	Ground	2 nd mate
	P11	Reserved	1. The pin corresponding to P11 in the backplane receptacle connector is also reserved 2. The corresponding pin to be mated with P11 in the power cable receptacle connector will always be grounded.
	P12	Ground	1 st mate
	P13	V ₁₂	12V power, pre-charge, 2 nd mate
	P14	V ₁₂	12V power
	P15	V ₁₂	12V power

The following points should be noted:

All pins are in a single row, with a 1.27 mm (.050") pitch.

- The comments on the mating sequence in Table 3-3 apply to the case of backplane blindmate connector only. In this case, the mating sequences are: (1) the ground pins P4 and P12; (2) the pre-charge power pins and the other ground pins; and (3) the signal pins and the rest of the power pins.
- There are three power pins for each voltage. One pin from each voltage is used for precharge in the backplane blind-mate situation.
- If a device uses 3.3 V, then all V₃₃ pins must be terminated. Otherwise, it is optional to terminate any of the V₃₃ pins. If a device uses 5.0 V, then all V₅ pins must be terminated. Otherwise, it is optional to terminate any of the V₅ pins.
- If a device uses 12.0 V, then all V₁₂ pins must be terminated. Otherwise, it is optional to terminate any of the V₁₂ pins.

3.5.1 ATA Bus Interface Connector (J1, Section C)

On the MaXLine Plus II 250GB AT hard disk drives, the SATA bus interface cable connector (J1, section C) is a standard 7-pin SATA.

To prevent the possibility of incorrect installation, the connector has been keyed. This ensures that a connector cannot be installed upside down.

3.6 MOUNTING

Drive mounting orientation, clearance, and ventilation requirements are described in the following subsections.

3.6.1 Orientation

The mounting holes on the MaXLine Plus II 250GB AT hard disk drives allow the drive to be mounted in any orientation. Figure 3-9 and Figure 3-10 show the location of the three mounting holes on each side of the drive. The drive can also be mounted using the four mounting hole locations on the PCB side of the drive.

Note: It is highly recommended that the drive is hard mounted on to the chassis of the system being used for general operation, as well as for test purposes. Failure to hard mount the drive can result in erroneous errors during testing.

Drives can be mounted in any orientation. Normal position is with the PCB facing down.

All dimensions are in millimeters. For mounting, #6-32 UNC screws are recommended.

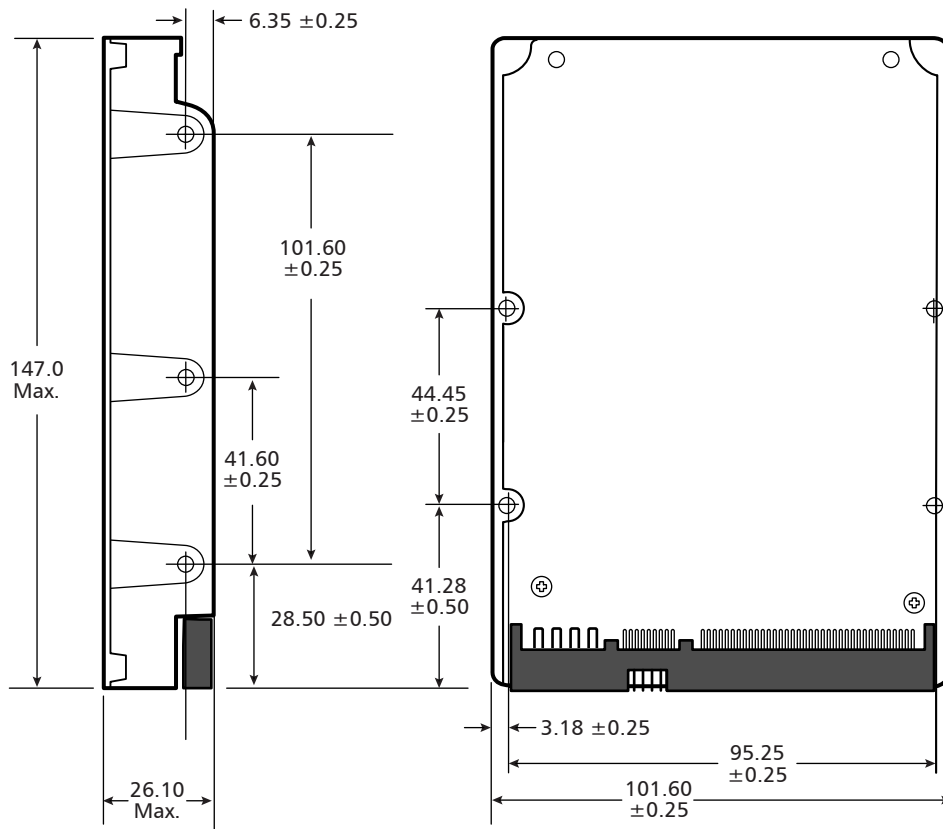

Figure 3-9 Mounting Dimensions for the MaXLine Plus II 250GB AT Hard Disk Drives

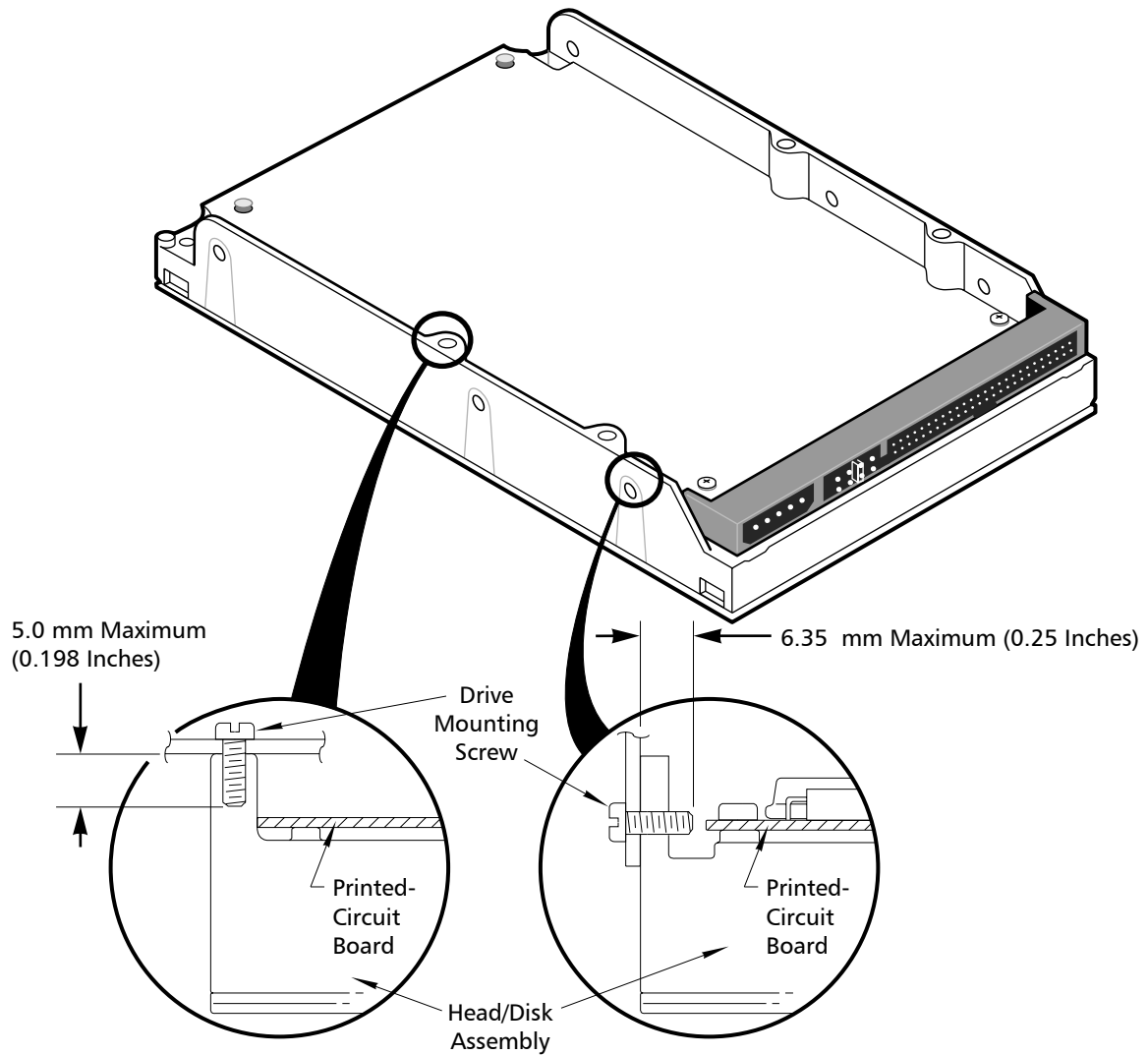

Figure 3-10 Mounting Screw Clearance for the Maxtor Hard Disk Drives

CAUTION: The PCB is very close to the mounting holes. Do not exceed the specified length for the mounting screws. The specified screw length allows full use of the mounting hole threads, while avoiding damaging or placing unwanted stress on the PCB. Figure 3-10 specifies the minimum clearance between the PCB and the screws in the mounting holes. To avoid stripping the mounting hole threads, the maximum torque applied to the screws must not exceed 8 inch-pounds. A maximum screw length of 0.25 inches may be used.

3.6.2 Clearance

Clearance from the drive to any other surface (except mounting surfaces) must be a minimum of 1.25 mm (0.05 inches).

3.6.3 Ventilation

The MaXLine Plus II 250GB AT hard disk drives operate without a cooling fan, provided the ambient air temperature does not exceed 131°F (55°C) at any point along the drive form factor envelope.

FOR SYSTEMS WITH A MOTHERBOARD ATA/SATA ADAPTER

You can install the MaXLine Plus II 250GB AT hard disk drives in an AT-compatible system that contains a 40-pin ATA bus connector/SATA on the motherboard.

To connect the drive to the motherboard, use a 40 conductor ribbon cable (80 conductor ribbon cable if using Ultra ATA/66/100 or /133 drive) 18 inches in length or shorter. Ensure that pin 1 of the drive is connected to pin 1 of the motherboard connector. To connect the drive to the motherboard for the MaXLine Plus II 250GB AT SATA drives, use a SATA cable 1 meter long or shorter. Ensure that pin 1 of the drive is connected to pin 1 of the motherboard connector.

3.7 FOR SYSTEMS WITH AN ATA ADAPTER BOARD

To install the MaXLine Plus II 250GB AT hard disk drive in an AT-compatible system without a 40-pin ATA bus connector/SATA connector on its motherboard, you need a third-party IDE-compatible adapter board.

3.7.1 Adapter Board Installation

Carefully read the manual that accompanies your adapter board before installing it. Make sure that all the jumpers are set properly and that there are no address or signal conflicts. You must also investigate to see if your AT-compatible system contains a combination floppy and hard disk controller board. If it does, you must disable the hard disk drive controller functions on that controller board before proceeding.

Once you have disabled the hard disk drive controller functions on the floppy/hard drive controller, install the adapter board. Again, make sure that you have set all jumper straps on the adapter board to avoid addressing and signal conflicts.

Note: For Sections 3.3 and 3.7, power should be turned off on the computer before installing the drive.

3.7.1.1 Connecting the Adapter Board and the Drive

Use a 40-pin/SATA cable to connect the drive to the board.
See figure 3-11.

To connect the drive to the board:

1. Insert the 40-pin cable/SATA connector into the mating connector of the adapter board. Make sure that pin 1 of the connector matches with pin 1 on the cable.
2. Insert the other end of the cable into the header on the drive. When inserting this end of the cable, make sure that pin 1 of the cable connects to pin 1 of the drive connector.
3. Secure the drive to the system chassis by using the mounting screws, as shown in Figure 3-12.

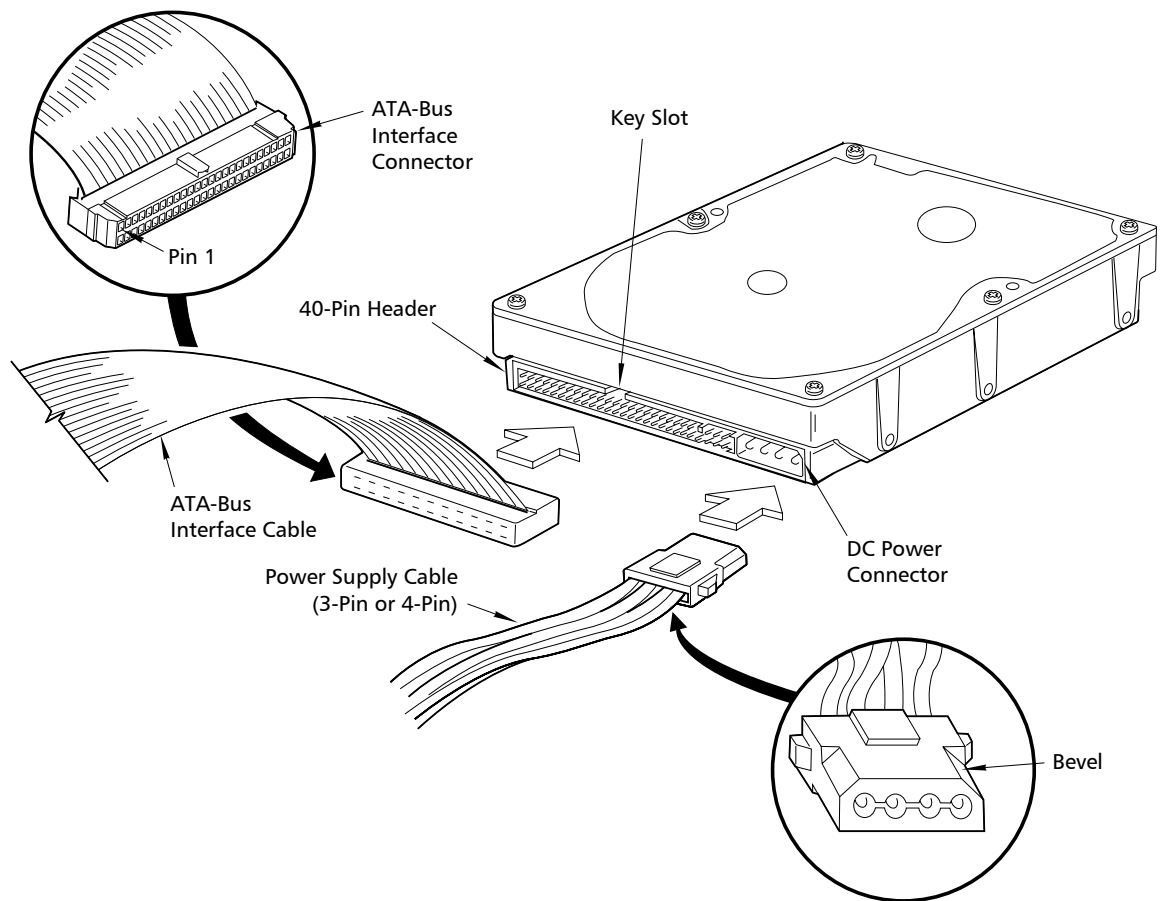

Figure 3-11 Drive Power Supply and ATA Bus Interface Cables

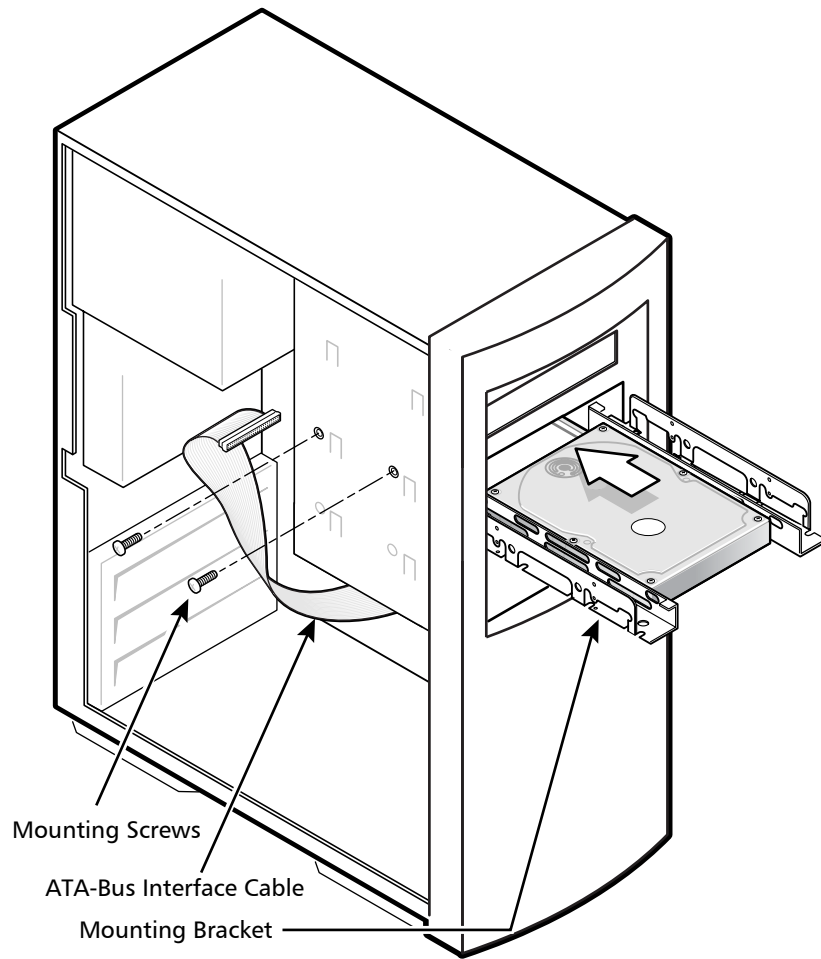

Figure 3-12 *Completing the Drive Installation*

3.8 TECHNIQUES IN DRIVE CONFIGURATION

3.8.1 The 528-Megabytes Barrier

Older BIOS that only support Int 13 commands for accessing ATA drives through DOS based operating systems will be limited to use only 1024 cylinders. This will reduce the effective capacity of the drive to 528Mbytes.

Whenever possible the MaXLine Plus II 250GB AT drive should be used on systems that support LBA translation to ensure the use of the entire capacity of the disk drive. If that is not possible the following are some techniques that can be used to overcome this barrier.

- Use a third party software program that translates the hard drive parameters to an acceptable configuration for MS-DOS.
- Use a hard disk controller that translates the hard drive parameters to an appropriate setup for both MS-DOS and the computer system's ROM-BIOS.
- Insert the Cylinder Limitation Jumper (CLJ) on the drive (see Section 3.3.1.4).

3.8.2 The 8.4-Gigabytes Barrier

Newer BIOS's allow users to configure disk drives to go beyond the 528MB barrier by using several BIOS translation schemes. However, while using these translations the BIOS using Int 13 functions are limited to 24 bits of addressing which results in another barrier at the 8.4GB capacity.

To overcome this barrier a new set of Int 13 extensions are being implemented by most BIOS manufacturers. The new Int 13 extension allows for four words of addressing space (64 bits) resulting in 9.4 Terrabytes of accessible space.

Whenever possible the MaXLine Plus II 250GB AT drive should be used on systems with BIOS that support Int 13 extensions. If that is not possible the following are some techniques that can be used to overcome this barrier:

- Use a third party software that supplements the BIOS and adds Int 13 extension support.
- Obtain a BIOS upgrade from the system board manufacturer. Many system board manufacturers allow their BIOS to be upgraded in the field using special download utilities. Information on BIOS upgrades can be obtained on the System Board Customer Service respective web sites on the Internet.
- Insert the Cylinder Limitation Jumper (CLJ) on the drive (see Section 3.3.1.4).

3.8.3 Operating system limitations

Most popular operating systems available today have additional limitations which affect the use of large capacity drives. However, these limitations can not be corrected on the BIOS and it is up to the operating system manufacturers to release improved versions to address these problems.

DOS and Windows 95 use a File Allocation Table (FAT) size of 16 bits which will only support partitions up to 2.1 GB. Windows 95 OSR2, Windows 98, and Windows ME use a FAT size of 32 bits, allowing partitions of up to 2.2 terrabytes. Windows NT, 2000, and XP Use NTFS, which allows partition sizes up to 16 terrabytes.

3.9 SYSTEM STARTUP AND OPERATION

Once you have installed the MaXLine Plus II 250GB AT hard disk drive, and adapter board (if required) in the host system, you are ready to partition and format the drive for operation. To set up the drive correctly, follow these steps:

1. Power on the system.
2. Run the SETUP program. This is generally on a Diagnostics or Utilities disk, or within the system's BIOS. Some system BIOS have an auto-detecting feature making SETUP unnecessary.
3. Enter the appropriate parameters.

The SETUP program allows you to enter the types of optional hardware installed—such as the hard disk drive type, the floppy disk drive capacity, and the display adapter type. The system's BIOS uses this information to initialize the system when the power is switched on. For instructions on how to use the SETUP program, refer to the system manual for your PC.

During the AT system CMOS setup, you must enter the drive type for the MaXLine Plus II 250GB AT hard disk drives. The drive supports the translation of its physical drive geometry parameters such as cylinders, heads, and sectors per track to a logical addressing mode. The drive can work with different BIOS drive-type tables of the various host systems.

You can choose any drive type that does not exceed the capacity of the drive. Table 3-3 gives the logical parameters that provide the maximum capacity on the MaXLine Plus II 250GB AT family of hard disk drives.

Table 3-4 Logical Addressing Format

MODELS	INTERFACE	CYL	HD	SPT	MAX LBA	CAPACITY
7Y250M0	SATA 150 8 MB Buffer	486,344	16	63	490,234,752	250GB
7Y250P0	PATA/133 8 MB Buffer	486,344	16	63	490,234,752	250GB

Note: *Capacity may be restricted to 8.4GB (or less) due to system BIOS limitations. Check with your system manufacturer to determine if your BIOS supports LBA Mode for hard drives greater than 8.4GB. Default logical cylinders is limited to 16,383 as per the ATA-4 specifications. To match the logical specifications of the drive to the drive type of a particular BIOS, consult the system's drive-type table. This table specifies the number of cylinders, heads, and sectors for a particular drive type.

You must choose a drive type that meets the following requirements:

For the MaXLine Plus II 250GB AT: Logical Cylinders x Logical Heads x Logical Sectors/Track x 512 = 8,455,200,768

4. Boot the system using the operating system installation disk—for example, MS-DOS—then follow the installation instructions in the operating system manual.

Chapter 4

PRODUCT SPECIFICATIONS

4.1 Models and Capacities

<i>MODELS</i>	<i>7Y250PO/7Y250MO</i>
Formatted Capacity (GB LBA Mode)	250GB
GB means 1 billion bytes. Total accessible capacity varies depending on operating environment.	

4.2 Drive Configuration

Sectors per Drive (max LBA)	490,234,752
Integrated Interface	Maxtor Ultra ATA/133 (ATA-5/ATA-6), SATA 150 MB 8 MB Buffer
Recording Method	RLL EEP4
Servo Type	Embedded
Number of Servo Sectors	192
Data Zones per Surface	16
Data Sectors per Track (ID/OD)	610/1102
Areal Density (Gbits/in ² max, ID/OD)	54.752
Recording Density (kbp, ID/OD)	ID = 770 OD = 615
Track Density (ktpi)	89 ktpi

Performance Specifications

Seek Times (typical read, ms)	
Track-to-Track	0.8
Average (normal seek)	≤9.0
Full Stroke (normal seek)	≤7.0
Average Latency (ms)	4.17
Controller Overhead (ms)	< 0.3
Rotation Speed (RPM ±0.1%)	7200
Data Transfer Speed (MByte/sec max)	
To/From Interface (Maxtor Ultra ATA/133, up to)	133
To/From Interface (SATA with 8 MB Buffer)	150
To/From Media (ID/OD up to nn.n, where nn.n is the maximum transfer rate possible)	ID = 460 OD = 803
Sustained (ID/OD up to nn.n, where nn.n is the maximum transfer rate possible)	ID = 37 OD = 67
Data Buffer Size (MB)/Type	8 MB
Drive Ready Time (typical sec)	< 8.0

4.3 Physical Dimensions

PARAMETER	VALUE
Height (maximum in mm)	26.10
Width (typical mm)	101.6
Depth (in. and mm)	147
Weight (maximum in grams)	630

4.4 Power Requirements

<i>MODE</i>	<i>12V (MA)</i>	<i>5V (MA)</i>	<i>POWER (W)</i>
Spin-up (peak)	1566.2	841.6	23.2
Seek	666.4	931.3	12.6
Read/Write	556.4	665.1	9.5
Idle	456.3	670.8	8.8
Standby	37.2	119.7	1.0
Sleep	37.2	118.1	1.0

4.5 Power Mode Definitions

Spin-up

The drive is spinning up following initial application of power and has not yet reached full speed.

Seek

A random access operation by the drive.

Read/Write

Data is being read from or written to the drive.

Idle

The drive is spinning, the actuator is parked and powered off and all other circuitry is powered on.

The drive is capable of responding to read commands within 40 ms.

Standby

The motor is not spinning. The drive will leave this mode upon receipt of a command that requires disk access. The time-out value for this mode is programmable. The buffer is active to accept write data.

Sleep

This is the lowest power state – with the interface set to inactive. A software or hardware reset is required to return the drive to the Standby state.

4.6 EPA Energy Star Compliance

Maxtor Corporation supports the goals of the U.S. Environmental Protection Agency's Energy Star program to reduce the electrical power consumption of computer equipment.

4.7 Environmental Limits

PARAMETER	OPERATING	NON-OPERATING/ STORAGE
Temperature	5° C to 55° C (with no ARR impact) 0° C to 60° C (Margin Demonstrated ¹)	low temperature (-40° C) high temperature (71° C) per MIL-STD-810E, method 501.3, climatic category; hot-induced conditions.
Thermal Gradient	25° C per hour (maximum)	
Relative Humidity	5% to 95% (non-condensing)	
Wet Bulb	30° C (maximum)	
Altitude (relative to sea level)	-650 to 10,000 feet	-650 to 40,000 feet
Acoustic Noise ²	IDLE MODE <i>(Track Following at Speed)</i>	NORMAL SEEK MODE
Fluid Bearing	2.9 bel average 3.4 bel maximum	4.0 bel average 4.2 bel maximum

Notes:

1. Margin Demonstrated implies the product will operate at the stated conditions with an acceptable impact to the ARR specification for any OEM requiring those values in their purchase specification.
2. The testing performed by Maxtor is consistent with ISO 7779. Variation in acoustic levels from the idle specification may occur due to offline activity according to the SMART specification and/or atmospheric conditions.

4.8 Shock and Vibration

PARAMETER	OPERATING	NON-OPERATING
Mechanical Shock	R=0.988/shock at 60 Gs; R= 0.999/shock at 30 Gs	2 msec, 1/2 sine R=0.90@> = 300G, 1 disk R=0.95@> = 250G, 1 disk R=0.99@> = 200G, 1 disk
Rotational Shock	R=0.988 @ 2000 rad/sec ²	R=0.95 @ 20K rad/sec ² , 0.5ms to 1ms input R=0.99 @ 15K rad/sec ² , 0.5ms to 1ms input
Rotational Random Vibration	5 - 2000 Hz 3.60 rad/sec ² RMS Overall	2 - 300 Hz 96.5 rad/sec ² RMS
Random Vibration	5 - 2000 Hz 0.44 GRMS Overall	PSD: 7 - 800 Hz at 3.08 GRMS No Damage
Swept Sine Vibration (1 octave/minute, peak amplitude) 10 to 300 Hz 301 to 400 Hz 401 to 500 Hz	1.0 G (0 to peak) amplitude, 1 octave per minute 0.25 G (0 to peak) amplitude, 1 octave per minute 0.0625 G (0 to peak) amplitude, 1 octave per minute	
Operating Sine Vibration 0.25 octave/min., 5- 1500 Hz	Frequency(Hz)/Acceleration(Gpk) 5 = 0.25" DA 8.8 = 0.25" DA 9 = 1.000 100 = 1.000 300 = 0.060 885 = 0.060 890 = 0.100 895 = 0.070 1500 = 0.100	

4.9 Reliability Specifications

Annualized Return Rate

<1.0% Annualized Return Rate (ARR) indicates the average against products shipped. ARR includes all reasons for returns (failures, handling, damage, NDF) but does not include inventory credit returns.

Start/Stop Cycles

>50,000 This indicates the average minimum cycles for reliable start/stop function.

R=0.9998@ >4500, R=0.9995 @ >7500, R=0.5 @ >= 50000

Data Reliability

<1 per 10e15 bits read

Data errors (non-recoverable). Average data error rate allowed with all error recovery features activated.

Component Design Life

5 years (*minimum*)

Component design life is defined as a.) the time period before identified wear-out mechanisms impact the failure rate, or b.) the time period up to the wear-out point when useful component life expires.

4.10 EMC/EMI

4.10.1 Radiated Electromagnetic Field Emissions - EMC Compliance

The hard disk drive mechanism is designed as a subassembly for installation into a suitable enclosure and is therefore not subject to Subpart J of Part 15 of FCC Rules (47CFR15) or the Canadian Department of Communications Radio Interference Regulations. Although not required, the disk mechanism has been tested within a suitable end-use product and found to comply with Class B limits of the FCC Rules and Regulations of the Canadian Department of Communications.

The CE Marking indicates conformity with the European Union Low Voltage Directive (73/23/EEC) when the disk mechanism is installed in a typical personal computer. Maxtor recommends that testing and analysis for EMC compliance be performed with the disk mechanism installed within the user's end-use application.

4.10.2 Canadian Emissions Statement

This digital apparatus does not exceed the Class B limits for radio noise emissions from digital apparatus as set out in the radio interference regulations of the Canadian department of communications.

Le present appareil numerique n'emet pas de bruit radioelectriques depassant les

limites applicables aux appareils numériques de Class B prescrites dans le règlement sur le brouillage radioélectrique édicté par le ministère des communications du Canada.

4.11 Safety Regulatory Compliance

All Maxtor hard drives comply with relevant product safety standards such as CE, CUL, TUV and UL rules and regulations. As delivered, Maxtor hard drives are designed for system integration before they are used.

Chapter 5

ATA BUS INTERFACE AND ATA COMMANDS

This chapter describes the interface between the MaxLine Plus II 250GB AT hard disk drive and the ATA bus. The commands that are issued from the host to control the drive are listed, as well as the electrical and mechanical characteristics of the interface.

5.1 INTRODUCTION

MaxLine Plus II 250GB AT hard disk drive use the standard ATA/ATAPI interface. Support of various options in the standard are explained in the following sections.

5.2 MECHANICAL INTERFACE

5.2.1 Signal Cable and Connector

The MaxLine Plus II 250GB AT hard disk drive contains a 40-pin unitized connector for both signal and power connections as well as configuration jumpers. The dimensions and specifications of the unitized connector comply with Annex. A in the ATA/ATAPI standard.

The MaxLine Plus II 250GB AT drive require the use of an 80 conductor cable (ATA/ATAPI-6, Annex. A, Figure A.4 and description) to support the drive's Ultra DMA capability.

5.3 ELECTRICAL INTERFACE

5.3.1 ATA Bus Interface

5.3.1.1 Electrical Characteristics

Signals on the ATA interface are assigned to connector pins according to Annex. A in the ATA/ATAPI-6 standard for the 80 conductor cable assembly. The signaling protocol complies with clause 9 and signal timing complies with clause 10 of the standard.

The MaxLine Plus II 250GB AT hard disk drive support all Ultra DMA Data Transfer modes (0 - 5) defined in the ATA/ATAPI-6 standard. In addition, these drives support Mode 6, and can send and receive data at the full 133MB/s transfer rate. Hosts may assert the RESET- signal for longer than the minimum. When power is applied with RESET- asserted, the MaxLine Plus II 250GB AT disk media will not begin to spin up until RESET- is negated. This may reduce maximum current consumption for the

overall system.

5.4 REGISTER ADDRESS DECODING

The MaxLine Plus II 250GB AT hard disk drives allow their host systems to address the full set of command and control registers as specified in clause 7 of the ATA/ATAPI-6 standard.

5.5 COMMAND INTERFACE

5.5.1 General Feature Set

The μ Processor, Disk Controller, and ATA Interface electronics are contained in a proprietary ASIC developed by Maxtor.

5.5.2 Supported Commands

The MaxLine Plus II 250GB AT hard disk drive support all the mandatory commands from the general feature set for devices not supporting the Packet command feature set. Refer to the ATA/ATAPI-6 standard for a detailed description of these commands. The IDENTIFY DRIVE command, however, is elaborated in the section "Identify Drive Command" on page 5-5.

Table 5-1 lists the supported commands.

Table 5-1 Supported Commands

Command	Command Code	Feature Register Value(s)
CHECK POWER MODE	98h, E5h	
DEVICE CONFIGURATION FREEZE LOCK	B1h	C1h
DEVICE CONFIGURATION IDENTIFY	B1h	C2h
DEVICE CONFIGURATION RESTORE	B1h	C0h
DEVICE CONFIGURATION SET	B1h	C3h
DOWNLOAD MICROCODE	92h	07h, 01h
EXECUTE DRIVE DIAGNOSTIC	90h	
FLUSH CACHE	E7h	
IDENTIFY DRIVE	ECh	
IDLE	97h, E3h	
IDLE IMMEDIATE	95h, E1h	

Table 5-1 Supported Commands

Command	Command Code	Feature Register Value(s)
NOP	00h	
READ BUFFER	E4h	
READ DMA	C8h, C9h	
READ MULTIPLE	C4h	
READ NATIVE MAX ADDRESS	F8h	
READ SECTOR(S)	20h, 21h	
READ VERIFY SECTOR(S)	40h, 41h	
SECURITY DISABLE PASSWORD	F6h	
SECURITY ERASE PREPARE	F3h	
SECURITY ERASE UNIT	F4h	
SECURITY FREEZE LOCK	F5H	
SECURITY SET PASSWORD	F1h	
SECURITY UNLOCK	F2h	
SEEK	70h	
SET FEATURES	EFh	Note 1
SET MAX ADDRESS	F9h	00h
SET MAX SET PASSWORD	F9h	01h
SET MAX LOCK	F9h	02h
SET MAX UNLOCK	F9h	03h
SET MAX FREEZE LOCK	F9h	04h
SET MULTIPLE MODE	C6h	
SLEEP	99h, E6h	
SMART DISABLE OPERATIONS	B0h	D9h
SMART ENABLE OPERATIONS	B0h	D8h
SMART ENABLE/DISABLE ATTRIBUTE AUTOSAVE	B0h	D2h

Table 5-1 Supported Commands

Command	Command Code	Feature Register Value(s)
SMART EXECUTE OFF-LINE IMMEDIATE	B0h	D4h
SMART READ DATA	B0h	D0h
SMART READ LOG	B0h	D5h
SMART RETURN STATUS	B0h	DAh
SMART SAVE ATTRIBUTE VALUES	B0h	D3h
SMART WRITE LOG	B0h	D6h
STANDBY	96h, E2h	
STANDBY IMMEDIATE	94h, E0h	
WRITE BUFFER	E8h	
WRITE DMA	CAh, CBh	
WRITE MULTIPLE	C5h	
WRITE SECTOR(S)	30h, 31h	

Note: 1. As defined in the ATA/ATAPI-6 standard.

Identify Drive Command

This command allows the host to receive parameter information from the drive.

When the command is received, the drive:

1. Sets BSY
2. Stores the required parameter information in the sector buffer
3. Sets the DRQ bit
4. Generates an interrupt

The host may then read the information out of the sector buffer. Parameter words in the buffer are shown in Table 5-2.

Note: All reserved bits or words should be zeroes.

Table 5-2 Identify Drive Command Parameters

Word	CONTENT DESCRIPTION
0	General configuration bit-significant information:
	15: 0 = ATA device
	14-8: Retired
	7: 1 = removable media device
	6: Obsolete
	5-3: Retired
	2: Response incomplete
	1: Retired
	0: Reserved
1	Obsolete
2	Specific configuration
3	Obsolete
4-5	Retired
6	Obsolete
7-8	Reserved for assignment by the CompactFlash Association
9	Retired
10-19	Serial number (20 ASCII characters)

Table 5-2 Identify Drive Command Parameters

Word	CONTENT DESCRIPTION
20-21	Retired
22	Reserved
23-26	Firmware revision (8 ASCII characters)
27-46	Model number (40 ASCII characters)
47	15-8: 80h
	7-0: 00h = Reserved
	01h-FFh: = Maximum number of sectors that shall be transferred per interrupt on READ/WRITE MULTIPLE commands
48	Reserved
49	Capabilities
	15-14: Reserved for the IDENTIFY PACKET DEVICE command.
	13: 1 = Standby timer values as specified in this standard are supported. 0 = Standby timer values shall be managed by the device
	12: Reserved for the IDENTIFY PACKET DEVICE command.
	11: 1 = IORDY supported. 0 = IORDY may be supported
	10: 1 = IORDY may be disabled
	9: 1 = LBA supported
	8: 1 = DMA supported.
	7-0: Retired
50	Capabilities
	15: Shall be cleared to zero.
	14: Shall be set to one.
	13-2: Reserved.
	1: Obsolete
	0: Shall be set to one to indicate a device specific Standby timer value minimum.
51-52	Obsolete

Table 5-2 Identify Drive Command Parameters

Word	CONTENT DESCRIPTION
53	15-3: Reserved
	2: 1 = the fields reported in word 88 are valid. 0 = the fields reported in word 88 are not valid
	1: 1 = the fields reported in words (70:64) are valid. 0 = the fields reported in words (70:64) are not valid
	0: Obsolete
54-58	Obsolete
59	15-9: Reserved
	8: 1 = Multiple sector setting is valid
	7-0: xxh = Current setting for number of sectors that shall be transferred per interrupt on R/W Multiple command
60-61	Total number of user addressable sectors
62	Obsolete
63	15-11: Reserved
	10: 1 = Multiword DMA mode 2 is selected. 0 = Multiword DMA mode 2 is not selected
	9: 1 = Multiword DMA mode 1 is selected. 0 = Multiword DMA mode 1 is not selected
	8: 1 = Multiword DMA mode 0 is selected. 0 = Multiword DMA mode 0 is not selected
	7-3: Reserved
	2: 1 = Multiword DMA mode 2 and below are supported
	1: 1 = Multiword DMA mode 1 and below are supported
	0: 1 = Multiword DMA mode 0 is supported
	64
7-0: PIO modes supported	
65	Minimum Multiword DMA transfer cycle time per word
	15-0: Cycle time in nanoseconds
66	Manufacturer's recommended Multiword DMA transfer cycle time
	15-0: Cycle time in nanoseconds

Table 5-2 Identify Drive Command Parameters

Word	CONTENT DESCRIPTION
67	Minimum PIO transfer cycle time without flow control
	15-0: Cycle time in nanoseconds
68	Minimum PIO transfer cycle time with IORDY flow control
	15-0: Cycle time in nanoseconds
69-70	Reserved (for future command overlap and queuing)
71-74	Reserved for IDENTIFY PACKET DEVICE command.
75	Queue depth
	15-5: Reserved
	4-0: Maximum queue depth – 1
76-79	Reserved for Serial ATA
80	Major version number
	0000h or FFFFh = device does not report version
	15: Reserved
	14: Reserved for ATA/ATAPI-14
	13: Reserved for ATA/ATAPI-13
	12: Reserved for ATA/ATAPI-12
	11: Reserved for ATA/ATAPI-11
	10: Reserved for ATA/ATAPI-10
	9: Reserved for ATA/ATAPI-9
	8: Reserved for ATA/ATAPI-8
	7: Reserved for ATA/ATAPI-7
	6: 1 = supports ATA/ATAPI-6
	5: 1 = supports ATA/ATAPI-5
	4: 1 = supports ATA/ATAPI-4
	3: 1 = supports ATA-3
	2: Obsolete
1: Obsolete	
0: Reserved	

Table 5-2 Identify Drive Command Parameters

Word	CONTENT DESCRIPTION
81	Minor version number
	0000h or FFFFh = device does not report version. 0001h-FFFEh = see 6.16.41 of ATA/ATAPI-7 specification
82	Command set supported.
	15: Obsolete
	14: 1 = NOP command supported
	13: 1 = READ BUFFER command supported
	12: 1 = WRITE BUFFER command supported
	11: Obsolete
	10: 1 = Host Protected Area feature set supported
	9: 1 = DEVICE RESET command supported
	8: 1 = SERVICE interrupt supported
	7: 1 = release interrupt supported
	6: 1 = look-ahead supported
	5: 1 = write cache supported
	4: Shall be cleared to zero to indicate that the PACKET Command feature set is not supported
	3: 1 = mandatory Power Management feature set supported
	2: 1 = Removable Media feature set supported
	1: 1 = Security Mode feature set supported
0: 1 = SMART feature set supported	
83	Command sets supported.
	15: Shall be cleared to zero
	14: Shall be set to on
	13: 1 = FLUSH CACHE EXT command supported
	12: 1 = mandatory FLUSH CACHE command supported
	11: 1 = Device Configuration Overlay feature set supported
	10: 1 = 48-bit Address feature set supported
	9: 1 = Automatic Acoustic Management feature set supported
	8: 1 = SET MAX security extension supported

Table 5-2 Identify Drive Command Parameters

Word	CONTENT DESCRIPTION
83	7: See Address Offset Reserved Area Boot, INCITS TR27:2001
	6: 1 = SET FEATURES subcommand required to spinup after power-up
	5: 1 = Power-Up In Standby feature set supported
	4: 1 = Removable Media Status Notification feature set supported
	3: 1 = Advanced Power Management feature set supported
	2: 1 = CFA feature set supported
	1: 1 = READ/WRITE DMA QUEUED supported
	0: 1 = DOWNLOAD MICROCODE command supported
84	Command set/feature supported extension.
	15: Shall be cleared to zero
	14: Shall be set to one
	13-8: Reserved
	7: 1 = WRITE DMA QUEUED FUA EXT command supported
	6: 1 = WRITE DMA FUA EXT and WRITE MULTIPLE FUA EXT commands supported
	5: 1 = General Purpose Logging feature set supported
	4: 1 = Streaming feature set supported
	3: 1 = Media Card Pass Through Command feature set supported
	2: 1 = Media serial number supported
	1: 1 = SMART self-test supported
	0: 1 = SMART error logging supported
85	Command set/feature enabled.
	15: Obsolete
	14: 1 = NOP command enabled
	13: 1 = READ BUFFER command enabled
	12: 1 = WRITE BUFFER command enabled
	11: Obsolete
	10: 1 = Host Protected Area feature set enabled
	9: 1 = DEVICE RESET command enabled
8: 1 = SERVICE interrupt enabled	

Table 5-2 Identify Drive Command Parameters

Word	CONTENT DESCRIPTION
85	7: 1 = release interrupt enabled
	6: 1 = look-ahead enabled
	5: 1 = write cache enabled
	4: Shall be cleared to zero to indicate that the PACKET Command feature set is not supported.
	3: 1 = Power Management feature set enabled
	2: 1 = Removable Media feature set enabled
	1: 1 = Security Mode feature set enabled
	0: 1 = SMART feature set enabled
86	Command set/feature enabled.
	15-14: Reserved
	13: 1 = FLUSH CACHE EXT command supported
	12: 1 = FLUSH CACHE command supported
	11: 1 = Device Configuration Overlay supported
	10: 1 = 48-bit Address features set supported
	9: 1 = Automatic Acoustic Management feature set enabled
	8: 1 = SET MAX security extension enabled by SET MAX SET PASSWORD
	7: See Address Offset Reserved Area Boot, INCITS TR27:2001
	6: 1 = SET FEATURES subcommand required to spin-up after power-up
	5: 1 = Power-Up In Standby feature set enabled
	4: 1 = Removable Media Status Notification feature set enabled
	3: 1 = Advanced Power Management feature set enabled
	2: 1 = CFA feature set enabled
	1: 1 = READ/WRITE DMA QUEUED command supported
0: 1 = DOWNLOAD MICROCODE command supported	
87	Command set/feature default.
	15: Shall be cleared to zero
	14: Shall be set to one
	13-8: Reserved
	7: 1 = WRITE DMA QUEUED FUA EXT command supported

Table 5-2 Identify Drive Command Parameters

Word	CONTENT DESCRIPTION
87	6: 1 = WRITE DMA FUA EXT and WRITE MULTIPLE FUA EXT commands supported
	5: General Purpose Logging feature set supported
	4: 1 = Valid CONFIGURE STREAM command has been executed
	3: 1 = Media Card Pass Through Command feature set enabled
	2: 1 = Media serial number is valid
	1: 1 = SMART self-test supported
	0: 1 = SMART error logging supported
88	15: Reserved
	14: 1 = Ultra DMA mode 6 is selected. 0 = Ultra DMA mode 6 is not selected
	13: 1 = Ultra DMA mode 5 is selected. 0 = Ultra DMA mode 5 is not selected
	12: 1 = Ultra DMA mode 4 is selected. 0 = Ultra DMA mode 4 is not selected
	11: 1 = Ultra DMA mode 3 is selected. 0 = Ultra DMA mode 3 is not selected
	10: 1 = Ultra DMA mode 2 is selected. 0 = Ultra DMA mode 2 is not selected
	9: 1 = Ultra DMA mode 1 is selected. 0 = Ultra DMA mode 1 is not selected
	8: 1 = Ultra DMA mode 0 is selected. 0 = Ultra DMA mode 0 is not selected
	7: Reserved
	6: 1 = Ultra DMA mode 6 and below are supported
	5: 1 = Ultra DMA mode 5 and below are supported
	4: 1 = Ultra DMA mode 4 and below are supported
	3: 1 = Ultra DMA mode 3 and below are supported
	2: 1 = Ultra DMA mode 2 and below are supported
	1: 1 = Ultra DMA mode 1 and below are supported
0: 1 = Ultra DMA mode 0 is supported	
89	Time required for security erase unit completion
90	Time required for Enhanced security erase completion
91	Current advanced power management value
92	Master Password Revision Code

Table 5-2 Identify Drive Command Parameters

Word	CONTENT DESCRIPTION
93	Hardware reset result. The contents of bits (12:0) of this word shall change only during the execution of a hardware reset
15:	Shall be cleared to zero.
14:	Shall be set to one.
13:	1 = device detected CBLID- above ViH. 0 = device detected CBLID- below ViL
12-8:	Device 1 hardware reset result. Device 0 shall clear these bits to zero. Device shall set these bits as follows:
12:	Reserved.
11:	0 = Device 1 did not assert PDIAG-. 1 = Device 1 asserted PDIAG-.
10-9:	These bits indicate how Device 1 determined the device number:
	00 = Reserved.
	01 = a jumper was used.
	10 = the CSEL signal was used.
	11 = some other method was used or the method is unknown.
8:	Shall be set to one.
7-0:	Device 0 hardware reset result. Device 1 shall clear these bits to zero. Device shall set these bits as follows:
7:	Reserved.
6:	0 = Device 0 does not respond when Device 1 is selected. 1 = Device 0 responds when Device 1 is selected.
5:	0 = Device 0 did not detect the assertion of DASP-. 1 = Device 0 detected the assertion of DASP-
4:	0 = Device 0 did not detect the assertion of PDIAG-. 1 = Device 0 detected the assertion of PDIAG-.
3:	0 = Device 0 failed diagnostics. 1 = Device 0 passed diagnostics.
2-1:	These bits indicate how Device 0 determined the device number:
	00 = Reserved.
	01 = a jumper was used.
	10 = the CSEL signal was used.
	11 = some other method was used or the method is unknown.
0:	Shall be set to one.

Table 5-2 Identify Drive Command Parameters

Word	CONTENT DESCRIPTION
94	15-8: Vendor's recommended acoustic management value.
	7-0: Current automatic acoustic management value
95	Stream Minimum Request Size
96	Stream Transfer Time - DMA
97	Stream Access Latency - DMA
98-99	Streaming Performance Granularity
100-103	Maximum user LBA for 48-bit Address feature set.
104	Stream Transfer Time – PIO
105	Stream Access Latency – PIO
106	Physical sector size
	15: Shall be cleared to zero
	14: Shall be set to one
	13: 1 = Device has multiple logical sectors per physical sector.
	12-4: Reserved
	3-0: 2 ^X logical sectors per physical sector
107	Inter-seek delay for ISO-7779 acoustic testing in microseconds
108-126	Reserved
127	Removable Media Status Notification feature set support
	15-2: Reserved
	1-0:
	00 = Removable Media Status Notification feature set not supported
	01 = Removable Media Status Notification feature supported
	10 = Reserved
	11 = Reserved

Table 5-2 Identify Drive Command Parameters

Word	CONTENT DESCRIPTION
128	Security status
	15-9: Reserved
	8: Security level 0 = High, 1 = Maximum
	7-6: Reserved
	5: 1 = Enhanced security erase supported
	4: 1 = Security count expired
	3: 1 = Security frozen
	2: 1 = Security locked
	1: 1 = Security enabled
	0: 1 = Security supported
129-159	Vendor specific
160-254	Reserved
255	Integrity word
	15-8: Checksum
	7-0: Signature

Chapter 6

SERVICE AND SUPPORT

6.1 Product Support/Technical Assistance/Customer Service

For Product Service and Support Information please visit our site at:

www.maxtor.com for warranty service or www.maxtorkb.com for technical support.

Appendix A

BREAKING THE 137 GIGABYTE STORAGE BARRIER

This appendix provides information about the 137GB storage barrier. It discusses the history, cause and the solution to overcome this barrier.

A.1 Breaking the 137 Gigabyte Storage Barrier

Capacity barriers have been a fact of the personal computer world since its beginnings in the early 1980's. At least 10 different capacity barriers have occurred in the storage industry over the last 15 years. The most notable barriers seen previously have been at 528 megabytes and then at 8.4 gigabytes.

The most recent barrier which will be surmounted in 2001, is the 137-gigabyte limit on a single ATA drive. The first ATA devices to exceed 137 gigabytes will be four-platter hard disk drives with 40 gigabytes per platter, yielding 160 gigabytes per drive. These drives will be available in the second half of 2001. Later in the same year, capacity will continue to grow to 60 gigabytes per platter, and a three-disk, 180-gigabyte device will be available and shipping.

The ANSI NCITS T13 Technical Committee (also known as the ANSI ATA committee) has broken this barrier by incorporating a proposal from Maxtor into the ATA/ATAPI-6 draft standard that defines a method for 48-bit addressing on a single drive, giving more than 144 petabytes (144,000 gigabytes) of storage.

In addition, the proposal from Maxtor that was incorporated into ATA/ATAPI-6 defines a method for extending the maximum amount of data that can be transferred per command for ATA devices from 256 sectors (about 131 kilobytes) to 65,536 sectors (about 33 megabytes). This new method is particularly useful for applications that use extremely large files, such as those for A/V or multimedia.

The following sections will describe issues surrounding the 137-gigabyte barrier and the solution for breaking it.

A.1.1 History

Many of the "barriers" in the past resulted from BIOS and operating system issues caused by failure to anticipate the remarkable increases in device storage capacity by the people who designed hard disk structures, access routines, and operating systems many years ago. They thought, "Who will ever have xxx much storage?" In some cases, the barriers were caused by hardware or software bugs not found until hard disks had grown in size beyond a certain point where the bugs would occur.

Past barriers often frustrated people trying to add a new hard disk to an older system when they discovered that not all of the designed capacity of the hard disk was accessible. This inability to access the entire drive is referred to as a “capacity barrier” and it has been seen and overcome many times in the computer and disk drive industry.

The 137-gigabyte barrier is the result of the original design specification for the ATA interface that provided only 28 bits of address for data. This specification means a hard disk can have a maximum of 268,435,456 sectors of 512 bytes of data which puts the ATA interface maximum at 137.4 gigabytes.

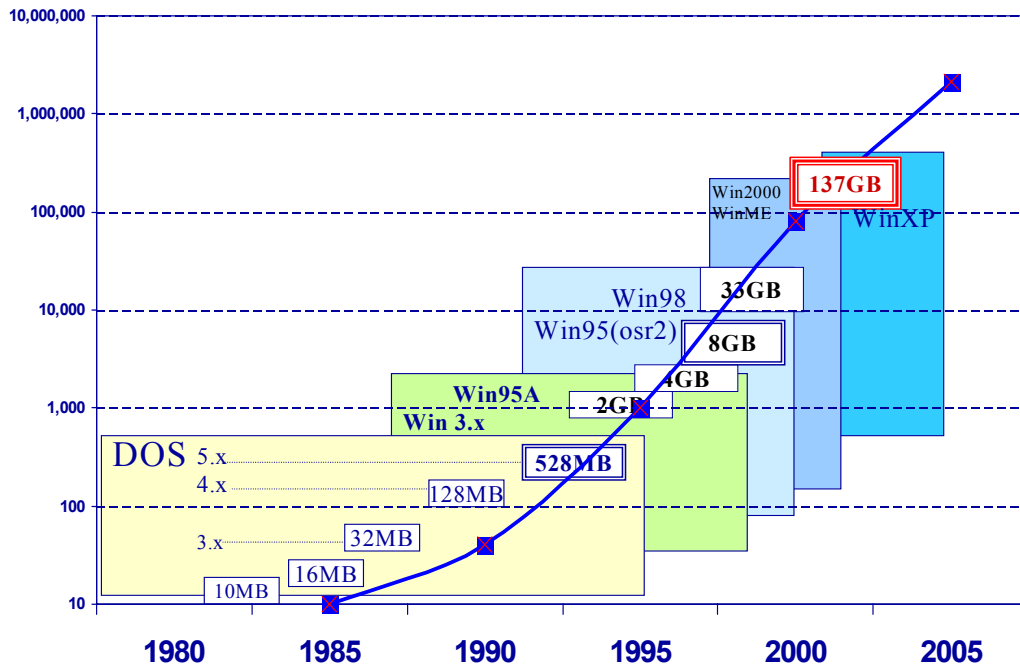

- | | |
|--------------------|---|
| 10 megabytes:early | PC/XT limit |
| 16 megabytes: | FAT 12 limit |
| 32 megabytes: | DOS 3.x limit |
| 128 megabytes: | DOS 4.x limit |
| 528 megabytes: | Early ATA BIOSs without BIOS extensions |
| 2.1 gigabytes: | DOS file system partition limit |
| 4.2 gigabytes: | CMOS extended CHS addressing limit (not widely experienced) |
| 8.4 gigabytes: | BIOS/Int13 24-bit addressing limit |
| 32 gigabytes: | BIOS limit |

A.1.2 Solving the 137 Gigabyte Capacity Barrier

As described earlier, the issue causing the 137-gigabyte barrier is the 28-bit addressing method of the original ATA specification. A change to expand this method was required to provide more address bits for the interface, allowing significant growth for many years to come. A critical issue in expanding the addressing capability was maintaining compatibility with the existing installed base of products.

A new ATA standard, ATA/ATAPI-6, has been in the works for some time, and the latest draft of this standard resolves this issue by increasing the maximum number of bits used for addressing from 28 to 48. This solution increases the maximum capacity of an ATA device to 144 petabytes while maintaining compatibility with current ATA products.

A.1.3 How is the Extension Implemented?

The 48-bit Address feature set provides a method to address devices with capacities up to approximately 144 petabytes by increasing the number of bits used to specify logical block addresses (LBAs) from 28 to 48. The feature set also provides a method to increase the number of sectors that can be transferred by a single command from 256 to 65,536 by increasing the number of bits specifying sector count to 16 bits.

New commands specific to this feature set have been defined so that devices can implement the new feature set in addition to previously defined commands. Devices implementing the 48-bit Address feature set commands will also implement commands that use 28-bit addressing in order to maintain interoperability with older system components. In addition, 8-bit and 48-bit commands may be intermixed.

The 48-bit Address feature set operates in LBA addressing only. Support of the 48-bit Address feature set is indicated in the IDENTIFY DEVICE response data. In a device implementing the 48-bit Address feature set, the registers used for addressing are, in fact, a two-byte deep FIFO. Each time one of these registers is written, the new content written is placed into the “most recently written” location and the previous content of the register is moved to “previous content” location. A host may read the “previous content” of the registers by first setting a bit in the Device Control register to 1 and then reading the desired register.

A.1.4 What Do the Drives Need to Meet the Spec?

The challenge to drive manufacturers is to develop and implement new interface chips on drives that can accept and decode the new 48-bit addressing scheme. Many functions of decoding the commands sent to and from the drive are automated in the silicon of the drive interface ASIC, and this is where drive manufacturers must update their designs. Maxtor is the leader in development efforts and is the first to deliver a product with the capacity and drive technology to deliver greater than 137 gigabytes of capacity.

A.1.5 What Else is Involved?

Effort is required from OS vendors to increase storage device addressing up to 48 bits or more. This increase will be a significant challenge for many OS vendors that have 32-bit code models. Adapting to 48-bit commands will be easy, but most vendors will stop filling data at the 32-bit boundary and pad the upper 16 bits with zeros,

leaving that space empty.

The BIOS companies will also have to perform some work to recognize the increased capacity of the devices attached to the bus and allow the extended 48-bit commands to pass on to the devices. Boot partitions will also be an issue for the capacity of the drive if the BIOS does not recognize the 48-bit addressing scheme at or before the system boots the OS from the hard drive.

Independent software driver efforts for legacy operating systems (Windows NT 4, Windows 98, and so on) will need to be implemented to allow higher-capacity devices to work on installed systems and recognize the maximum available capacity of the drive over the 137-gigabyte limit.

A.1.6 What is the Next Barrier?

While it is true that the ATA/ATAPI-6 standard defines a method to provide a total capacity for a device of 144 petabytes, the next limit will be imposed not by the ATA devices but by many of the popular operating systems in use today. This limit will be at 2.2 terabytes (2,200 gigabytes). This barrier exists because many of today's operating systems are based on 32-bit addressing. These operating systems include many flavors of Linux, Mac OS 9.x, and Windows 95, 98, ME, NT 4, 2000, and XP (Windows XP/64-bit also has the limit because of leveraged 32-bit code).

This barrier could be real as early as 2004 if current hard drive capacity rate increases continue along the same growth trends.

Appendix A: Terminology

- **BIOS:** (an acronym for Basic Input/Output System design): The BIOS processes and redirects all data as it is being accessed and stored.
- **FAT:** (an acronym for File Allocation Table): The FAT tells the computer where data has been stored on the hard drive.
- **CHS:** (an acronym for Cylinders, Heads, and Sectors): The basic layout components of a hard drive. INT 13h & INT 13h extensions: protocols used for accessing data on hard drives.

Appendix B: Big Numbers

- 131 kilobytes = 131,000 bytes
a little more than 30 pages of text
- 33 megabytes = 33,000,000 bytes
more than 8,000 pages of text or 25 300-page books
- 137 gigabytes = 137,000,000,000 bytes
more than 100,000 books, or the contents of a good library
- 2.2 terabytes = 2,200,000,000,000 bytes
almost 2,000,000 books, or the about content of the Library of Congress
- 144 petabytes = 144,000,000,000,000,000 bytes

120 billion books – (more than all that man has written)

- 9.4 zettabytes = 9,400,000,000,000,000,000 bytes

Appendix C: Resources

- Maxtor “Big Drive” web site for resource information:
<http://www.maxtor.com/bigdrive>
- ATA/ATAPI-6: <http://www.T13.org>

GLOSSARY

A

ACCESS – (v) Read, write, or update information on some storage medium, such as a disk. (n) One of these operations.

ACCESS TIME – The interval between the time a request for data is made by the system and the time the data is available from the drive. Access time includes the actual seek time, rotational latency, and command processing overhead time. See also seek, rotational latency, and overhead.

ACTUATOR – Also known as the *positioner*. The internal mechanism that moves the read/write head to the proper track. The Maxtor actuator consists of a rotary voice coil and the head mounting arms. One end of each head mounting arm attaches to the rotor with the read/write heads attached at the opposite end of each arm. As current is applied to the rotor, it rotates, positioning the heads over the desired cylinder on the media.

ALLOCATION – The process of assigning particular areas of the disk to particular files. See also allocation unit.

ALLOCATION UNIT – An allocation unit, also known as a *cluster*, is a group of sectors on the disk that can be reserved for the use of a particular file.

AVERAGE SEEK TIME – The average time it takes for the read/write head to move to a specific location. To compute the average seek time, you divide the time it takes to complete a large number of random seeks all over the disk by the number of seeks performed.

B

BACKUP – A copy of a file, directory, or volume on a separate storage device from the original, for the purpose of retrieval in case the original is accidentally erased, damaged, or destroyed.

BAD BLOCK – A block (usually the size of a sector) that cannot reliably hold data because of a media flaw or damaged format markings.

BAD TRACK TABLE – A label affixed to the casing of a hard disk drive that tells which tracks are flawed and cannot hold data. The listing is typed into the low-level formatting program when the drive is being installed. Because Maxtor disk drive's defect-management scheme handles all such flaws automatically, there is no need to concern yourself with bad track tables.

BIT – Abbreviation for binary digit. A binary digit may have one of two values—1 or 0. This contrasts with a decimal digit, which may have a value from 0 to 9. A bit is one of the logic 1 or logic 0 binary settings that make up a byte of data. See also byte.

BLOCK – A sector or group of sectors.

BPI – Abbreviation for *bits per inch*. A measure of how densely information is packed on a storage medium. Flux changes per inch is also a term commonly used in describing storage density on a magnetic surface.

BUFFER – An area of RAM reserved for temporary storage of data that is waiting to be sent to a device that is not yet ready to receive it. The data is usually on its way to or from the disk drive or some other peripheral device.

BUS – The part of a chip, circuit board, or interface designed to send and receive data.

BYTE – The basic unit of computer memory, large enough to hold one character of alphanumeric data. Comprised of eight bits. See also bit.

C

CACHE – Random-access memory used as a buffer between the CPU and a hard disk. Information more likely to be read or changed is placed in the cache, where it can be accessed more quickly to speed up general data flow.

CAPACITY – The amount of information that can be stored on a disk drive. The data is stored in bytes, and capacity is usually expressed in megabytes.

CDB – Command Descriptor Block. The SCSI structure used to communicate requests from an initiator (system) to a target (drive).

CLEAN ROOM – An environmentally controlled dust-free assembly or repair facility in which hard disk drives are assembled or can be opened for internal servicing.

CLUSTER – A group of sectors on a disk drive that is addressed as one logical unit by the operating system.

CONTROLLER – Short form of *disk controller*. The chip or complete circuit that translates computer data and commands into
CONTROLLER CARD – An adapter holding the control electronics for one or more hard disks, usually installed in a slot in the computer.

CPU – Acronym for *Central Processing Unit*. The microprocessor chip that performs the bulk of data processing in a computer.

CRC – Acronym for *Cyclic Redundancy Check*. An error detection code that is recorded within each sector and is used to see whether parts of a string of data are missing or erroneous.

CYLINDER – On a disk drive that has more than one recording surface and heads that move to various tracks, the group of all tracks located at a given head position. The number of cylinders times the number of heads equals the number of tracks per drive.

D

DATA SEPARATOR – On a disk drive that stores data and timing information in an encoded form, the circuit that extracts the data from the combined data and clock signal.

DEDICATED SERVO – A surface separate from the surface used for data that contains only disk timing and positioning information and contains no data.

DEFECT MANAGEMENT – A method that is implemented to ensure long term data integrity. Defect management eliminates the need for user defect maps. This is accomplished by scanning the disk drives at the factory for defective sectors. Defective sectors are deallocated prior to shipment. In addition, during regular use, the drive continues to scan and compensate for any new defective sectors on the disk.

DISK – In general, any circular-shaped data-storage medium that stores data on the flat surface of the platter. The most common type of disk is the magnetic disk, which stores data as magnetic patterns in a metal or metal-oxide coating. Magnetic disks come in two forms: floppy and hard. Optical recording is a newer disk technology that gives higher capacity storage but at slower access times.

DISK CONTROLLER – A plug-in board, or embedded circuitry on the drive, that passes information to and from the disk. The Maxtor disk drives all have controllers embedded on the drive printed-circuit board.

DISKWARE – The program instructions and data stored on the disk for use by a processor.

DMA – Acronym for *direct memory access*. A process by which data moves directly between a disk drive (or other device) and system memory without passing through the CPU, thus allowing the system to continue processing other tasks while the new data is being retrieved.

DRIVE – Short form of *disk drive*.

DRIVE GEOMETRY – The functional dimensions of a drive in terms of the number of heads, cylinders, and sectors per track. See also logical format.

E

ECC – Acronym for *error correction code*. The recording of extra verifying information encoded along with the disk data. The controller uses the extra information to check for data errors, and corrects the errors when possible.

EMBEDDED SERVO – A timing or location signal placed on the disk's surface on the tracks that also store data. These signals allow the actuator to fine-tune the position of the read/write heads.

ENCODING – The protocol by which particular data patterns are changed prior to being written on the disk surface as a pattern of On and Off or 1 and 0 signals.

EXTERNAL DRIVE – A drive mounted in an enclosure separate from the PC or computer system enclosure, with its own power supply and fan, and connected to the system by a cable.

F

FAT – Acronym for *file allocation table*. A data table stored on the outer edge of a disk that tells the operating system which sectors are allocated to each file and in what order.

FCI – Acronym for *flux changes per inch*. See also BPI.

FILE SERVER – A computer that provides network stations with controlled access to shareable resources. The network operating system is loaded on the file server, and most shareable devices (disk subsystems, printers) are attached to it. The file server controls system security and monitors station-to-station communications. A dedicated file server can be used only as a file server while it is on the network. A non-dedicated file server can be used simultaneously as a file server and a workstation.

FLUX DENSITY – The number of magnetic field patterns that can be stored in a given length of disk surface. The number is usually stated as flux changes per inch (FCI), with typical values in the thousands.

FLYING HEIGHT – The distance between the read/write head and the disk surface caused by a cushion of air that keeps the head from contacting the media. Smaller flying heights permit more dense storage of data, but require more precise mechanical designs.

FORMAT – To write onto the disk surface a magnetic track pattern that specifies the locations of the tracks and sectors. This information must exist on a disk before it can store any user data. Formatting erases any previously stored data.

FORMATTED CAPACITY – The amount of room left to store data on the disk after the required space has been used to write sector headers, boundary definitions, and timing information generated by a format operation. All Maxtor drive capacities are expressed in formatted capacity.

FORM FACTOR – The physical outer dimensions of a device as defined by industry standard. For example, most Maxtor disk drives use a 3 1/2-inch form factor.

G

GIGABYTE (GB) – One billion bytes (one thousand megabytes).

GUIDE RAILS – Plastic strips attached to the sides of a disk drive mounted in an IBM AT and compatible computers so that the drive easily slides into place.

H

HALF HEIGHT – Term used to describe a drive that occupies half the vertical space of the original full size 5 1/4-inch drive. 1.625 inches high.

HARD DISK – A type of storage medium that retains data as magnetic patterns on a rigid disk, usually made of an iron oxide or alloy over a magnesium or aluminum platter. Because hard disks spin more rapidly than floppy disks, and the head flies closer to the disk, hard disks can transfer data faster and store more in the same volume.

HARD ERROR – A repeatable error in disk data that persists when the disk is reread, usually caused by defects in the media surface.

HEAD – The tiny electromagnetic coil and metal pole piece used to create and read back the magnetic patterns (write and read information) on the media.

HIGH-CAPACITY DRIVE – By industry conventions typically a drive of 1 gigabytes or more.

HIGH-LEVEL FORMATTING – Formatting performed by the operating system's format program. Among other things, the formatting program creates the root directory and file allocation tables. See also low-level formatting.

HOME – Reference position track for re-calibration of the actuator, usually the outer track (track 0).

HOST ADAPTER – A plug-in board that forms the interface between a particular type of computer system bus and the disk drive.

I

INITIALIZE – See low level formatting.

INITIATOR – A SCSI device that requests another SCSI device to perform an operation. A common example of this is a system requesting data from a drive. The system is the initiator and the drive is the target.

INTERFACE – A hardware or software protocol, contained in the electronics of the disk controller and disk drive, that manages the exchange of data between the drive and computer.

INTERLEAVE – The arrangement of sectors on a track. A 1:1 interleave arranges the sectors so that the next sector arrives at the read/write heads just as the computer is ready to access it. See also interleave factor.

INTERLEAVE FACTOR – The number of sectors that pass beneath the read/write heads before the next numbered sector arrives. When the interleave factor is 3:1, a sector is read, two pass by, and then the next is read. It would take three revolutions of the disk to access a full track of data. Maxtor drives have an interleave of 1:1, so a full track of data can be accessed within one revolution of the disk, thus offering the highest data throughput possible.

INTERNAL DRIVE – A drive mounted inside one of a computer's drive bays (or a hard disk on a card, which is installed in one of the computer's slots).

J

JUMPER – A tiny box that slips over two pins that protrude from a circuit board. When in place, the jumper connects the pins electrically. Some board manufacturers use Dual In-Line Package (DIP) switches instead of jumpers.

K

KILOBYTE (K) – A unit of measure consisting of 1,024 (2^{10}) bytes.

L

LANDING ZONE – A position inside the disk's inner cylinder in a non data area reserved as a place to rest the heads during the time that power is off. Using this area prevents the heads from touching the surface in data areas upon power down, adding to the data integrity and reliability of the disk drive.

LATENCY – The period of time during which the read/write heads are waiting for the data to rotate into position so that it can be accessed. Based on a disk rotation speed of 3,662 rpm, the maximum latency time is 16.4 milliseconds, and the average latency time is 8.2 milliseconds.

LOGICAL FORMAT – The logical drive geometry that appears to an AT system BIOS as defined by the drive tables and stored in CMOS. With an installation program like Disk Manager, the drive can be redefined to any logical parameters necessary to adapt to the system drive tables.

LOOK AHEAD – The technique of buffering data into cache RAM by reading subsequent blocks in advance to anticipate the next request for data. The look ahead technique speeds up disk access of sequential blocks of data.

LOW-LEVEL FORMATTING – Formatting that creates the sectors on the platter surfaces so the operating system can access the required areas for generating the file structure. Maxtor drives are shipped with the low-level formatting already done.

LOW PROFILE – Describes drives built to the 3 1/2-inch form factor, which are only 1 inch high.

M

MB – See megabyte.

MEDIA – The magnetic film that is deposited or coated on an aluminum substrate which is very flat and in the shape of a disk. The media is overcoated with a lubricant to prevent damage to the heads or media during head take off and landing. The media is where the data is stored inside the disk in the form of magnetic flux or polarity changes.

MEGABYTE (MB) – A unit of measurement equal to 1,024 kilobytes, or 1,048,576 bytes except when referring to disk storage capacity.

1 MB = 1,000,000 bytes when referring to disk storage capacity.

See also kilobyte.

MEGAHERTZ – A measurement of frequency in millions of cycles per second.

MHz – See megahertz.

MICROPROCESSOR – The integrated circuit chip that performs the bulk of data processing and controls the operation of all of the parts of the system. A disk drive also contains a microprocessor to handle all of the internal functions of the drive and to support the embedded controller.

MICROSECOND (μ s) – One millionth of a second (.000001 sec.).

MILLISECOND (ms) – One thousandth of a second (.001 sec.).

MTTF – MTTF is a basic measure of reliability for non-repairable systems. It is the mean time expected until the first failure of a piece of equipment. MTTF is a statistical value and is meant to be the mean over a long period of time and large number of units. For constant failure rate systems, MTTF is the inverse of the failure rate. If failure rate is in failures/million hours, $MTTF = 1,000,000 / \text{Failure Rate}$ for components with exponential distributions.

MTTR – Mean Time To Repair. The average time it takes to repair a drive that has failed for some reason. This only takes into consideration the changing of the major sub-assemblies such as circuit board or sealed housing. Component level repair is not included in this number as this type of repair is not performed in the field.

O

OVERHEAD – The processing time of a command by the controller, host adapter or drive prior to any actual disk accesses taking place.

OVERWRITE – To write data on top of existing data, erasing it.

OXIDE – A metal-oxygen compound. Most magnetic coatings are combinations of iron or other metal oxides, and the term has become a general one for the magnetic coating on tape or disk.

P

PARTITION – A portion of a hard disk devoted to a particular operating system and accessed as one logical volume by the system.

PERFORMANCE – A measure of the speed of the drive during normal operation. Factors affecting performance are seek times, transfer rate and command overhead.

PERIPHERAL – A device added to a system as an enhancement to the basic CPU, such as a disk drive, tape drive or printer.

PHYSICAL FORMAT – The actual physical layout of cylinders, tracks, and sectors on a disk drive.

PLATED MEDIA – Disks that are covered with a hard metal alloy instead of an iron-oxide compound. Plated disks can store greater amounts of data in the same area as a coated disk.

PLATTER – An disk made of metal (or other rigid material) that is mounted inside a fixed disk drive. Most drives use more than one platter mounted on a single spindle (shaft) to provide more data storage surfaces in a small package. The platter is coated with a magnetic material that is used to store data as transitions of magnetic polarity.

POH – Acronym for *power on hours*. The unit of measurement for Mean Time Between Failure as expressed in the number of hours that power is applied to the device regardless of the amount of actual data transfer usage. See MTBF.

POSITIONER – See actuator.

R

RAM – Acronym for *random access memory*. An integrated circuit memory chip which allows information to be stored and retrieved by a microprocessor or controller. The information may be stored and retrieved in any order desired, and the address of one storage location is as readily accessible as any other.

RAM DISK – A “phantom disk drive” for which a section of system memory (RAM) is set aside to hold data, just as if it were a number of disk sectors. The access to this data is extremely fast but is lost when the system is reset or turned off.

READ AFTER WRITE – A mode of operation that has the computer read back each sector on the disk, checking that the data read back is the same as recorded. This slows disk operations, but raises reliability.

READ VERIFY – A disk mode where the disk reads in data to the controller, but the controller only checks for errors and does not pass the data on to the system.

READ/WRITE HEAD – The tiny electromagnetic coil and metal pole piece used to create and read back the magnetic patterns (write or read information) on the disk. Each side of each platter has its own read/write head.

REMOVABLE DISK – Generally said of disk drives where the disk itself is meant to be removed, and in particular of hard disks using disks mounted in cartridges. Their advantage is that multiple disks can be used to increase the amount of stored material, and that once removed, the disk can be stored away to prevent unauthorized use.

RLL – Run Length Limited. A method used on some hard disks to encode data into magnetic pulses. RLL requires more processing, but stores almost 50% more data per disk than the MFM method.

ROM – Acronym for *read only memory*. Usually in the form of an ROM in the controller that contains programs that can be accessed and read but not modified by the system.

ROTARY ACTUATOR – The rotary actuator replaces the stepper motor used in the past by many hard disk manufacturers. The rotary actuator is perfectly balanced and rotates around a single pivot point. It allows closed-loop feedback positioning of the heads, which is more accurate than stepper motors.

ROTATIONAL LATENCY – The delay between when the controller starts looking for a specific block of data on a track and when that block rotates around to where it can be read by the read/write head. On the average, it is half of the time needed for a full rotation (about 8 ms.).

S

SCSI – Acronym for *Small Computer System Interface*, an American National Standards Institute (ANSI) version of Shugart Associates' SASI interface between the computer and controller. SCSI has grown in popularity and is one of the most flexible and intelligent interfaces available.

SECTOR – A section of space along a track on the disk, or the data that is stored in that section. Hard disks most often have sectors that are 512 data bytes long plus several bytes overhead for error correcting codes. Each

sector is preceded by ID data known as a header, which cannot be overwritten.

SEEK – A movement of the disk read/write head in or out to a specific track.

SERVO DATA – Magnetic markings written on the media that guide the read/write heads to the proper position.

SERVO SURFACE – A separate surface containing only positioning and disk timing information but no data.

SETTLE TIME – The interval between when a track to track movement of the head stops, and when the residual vibration and movement dies down to a level sufficient for reliable reading or writing.

SHOCK RATING – A rating (expressed in Gs) of how much shock a disk drive can sustain without damage.

SOFT ERROR – An error in reading data from the disk that does not recur if the same data is reread. Often caused by power fluctuations or noise spikes.

SOFT SECTORED – Disks that mark the beginning of each sector of data within a track by a magnetic pattern.

SPINDLE – The center shaft of the disk upon which the drive's platters are mounted.

SPUTTER – A type of coating process used to apply the magnetic coating to some high-performance disks. In sputtering, the disks are placed in a vacuum chamber and the coating is vaporized and deposited on the disks. The resulting surface is hard, smooth, and capable of storing data at high density. Maxtor disk drives use sputtered thin film disks.

STEPPER – A type of motor that moves in discrete amounts for each input electrical pulse. Stepper motors used to be widely used for read/write head positioner, since they can be geared to move the head one track per step. Stepper motors are not as fast or reliable as the rotary voice coil actuators which Maxtor disk drives use.

SUBSTRATE – The material the disk platter is made of beneath the magnetic coating. Hard disks are generally made of aluminum or magnesium alloy (or glass, for optical disks) while the substrate of floppies is usually mylar.

SURFACE – The top or bottom side of the platter which is coated with the magnetic material for recording data. On some drives one surface may be reserved for positioning information.

T

THIN FILM – A type of coating, used for disk surfaces. Thin film surfaces allow more bits to be stored per disk.

TPI – Acronym for *tracks per inch*. The number of tracks or cylinders that are written in each inch of travel across the surface of a disk.

TRACK – One of the many concentric magnetic circle patterns written on a disk surface as a guide to where to store and read the data.

TRACK DENSITY – How closely the tracks are packed on a disk surface. The number is specified as tracks per inch (TPI).

TRACK TO TRACK SEEK TIME – The time required for the read/write heads to move to an adjacent track.

TRANSFER RATE – The rate at which the disk sends and receives data from the controller. Drive specifications usually reference a high number that is the burst mode rate for transferring data across the interface from the disk buffer to system RAM. Sustained data transfer is at a much lower rate because of system processing overhead, head switches, and seeks.

U

UNFORMATTED CAPACITY – The total number of bytes of data that could be fit onto a disk. Formatting the disk requires some of this space to record location, boundary definitions, and timing information. After formatting, user data can be stored on the remaining disk space, known as formatted capacity. The size of a Maxtor drive is expressed in formatted capacity.

V

VOICE COIL – A type of motor used to move the disk read/write head in and out to the right track. Voice-coil actuators work like loudspeakers with the force of a magnetic coil causing a proportionate movement of the head. Maxtor's actuator uses voice-coil technology, and thereby eliminates the high stress wearing parts found on stepper motor type actuators.

W

WEDGE SERVO – The position on every track that contains data used by the closed loop positioning control. This information is used to fine tune the position of the read/write heads exactly over the track center.

WINCHESTER DISKS – Hard disks that use a technology similar to an IBM model using Winchester as the code name. These disks use read/write heads that ride just above the magnetic surface, held up by the air flow created by the turning disk. When the disk stops turning, the heads land on the surface, which has a specially lubricated coating. Winchester disks must be sealed and have a filtration system since ordinary dust particles are large enough to catch between the head and the disk.

WRITE ONCE – In the context of optical disks, technologies that allow the drive to store data on a disk and read it back, but not to erase it.

INDEX

A

abbreviations 1-1
adapter board 2-4, 3-20

C

Cable Select 3-7
cable select (CS) jumper 3-6
clearance 3-19
command descriptions 5-2
connector, IDE 3-11, 3-16
cooling fan requirements 3-19

D

daisy-chain 2-3
daisy-chained 3-6
drive select (DS) jumper 3-7

F

faceplate 3-1
floppy drive 3-20

H

hardware options 3-5

I

IDE 2-4, 3-9, 3-12
IDE-bus interface 5-1
IDE-bus interface connector 3-11, 3-16
input power connections 3-11, 3-14
interface, IDE-bus 5-1

J

jumper configurations 3-6
jumper locations 3-5
jumper options 3-6

M

maximum screw torque 3-18
mechanical dimensions 3-1
motherboard 3-20
mounting 3-17
mounting dimensions 3-17
mounting holes 3-17
mounting screw clearance 3-18
mounting screws 3-18
MS-DOS 3-26

P

packing assembly 3-2
packing materials 3-2
power and AT bus connector 3-10
power and bus interface cables 3-21
power connector 3-9, 3-13

S

shipping container 3-2
Slave Present 3-7
slave present (SP) jumper 3-7

V

ventilation 3-19
ventilation requirements 3-17