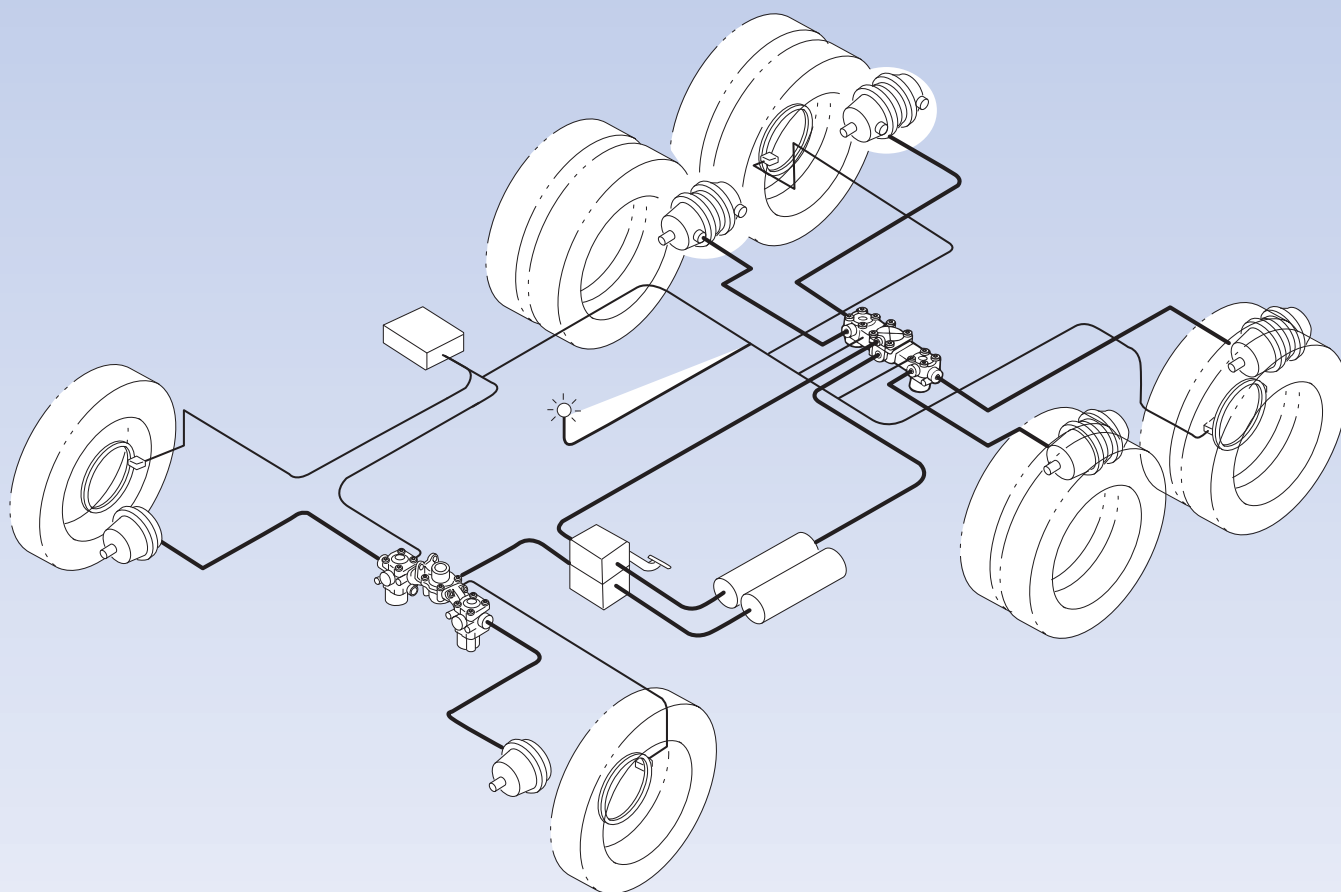


# ANTI-LOCK BRAKING SYSTEM (ABS) AND ELECTRONIC STABILITY CONTROLS (ESC)

## MAINTENANCE MANUAL



**WABCO**



## Table of contents

<b>1</b>	<b>General Information</b> .....	<b>6</b>
<b>2</b>	<b>Safety Information</b> .....	<b>8</b>
<b>3</b>	<b>Introduction</b> .....	<b>9</b>
3.1	Contents.....	9
3.1.1	<i>For Additional Information</i> .....	9
3.1.2	<i>Anti-Lock Braking System (ABS)</i> .....	9
3.1.3	<i>System Components</i> .....	10
3.2	System Configuration.....	14
<b>4</b>	<b>Stability and Safety Enhancement Systems</b> .....	<b>16</b>
4.1	ATC .....	16
4.2	ATC Components.....	16
<b>5</b>	<b>Diagnostics, Troubleshooting and Testing</b> .....	<b>23</b>
5.1	General .....	23
5.2	Maintenance Information .....	23
5.2.1	<i>Testing</i> .....	36
<b>6</b>	<b>Component Replacement</b> .....	<b>60</b>
6.1	Component Removal and Installation .....	60
6.1.1	<i>Wheel Speed Sensors</i> .....	60
<b>7</b>	<b>System Configurations</b> .....	<b>76</b>
7.1	System Configurations System Configuration Layouts.....	76
<b>8</b>	<b>Wiring Diagrams and Connectors</b> .....	<b>80</b>
8.1	Wiring Diagrams and Connectors ECU Connector Pin Assignments .....	80
8.1.1	<i>ECU (Frame-mounted)</i> .....	81
8.1.2	<i>ECU (Frame-mounted) with ESC and/or HSA</i> .....	81
8.1.3	<i>Basic ECU ABS Only with Optional Automatic Traction Control (ATC) (Cab-mounted)</i> .....	82
<b>9</b>	<b>SPN, SID, FMI Fault Codes</b> .....	<b>93</b>
9.1	SPN, SID, FMI Diagnostic Trouble Code List .....	93
<b>10</b>	<b>Appendix I</b> .....	<b>122</b>
10.1	Reconfiguration Procedure .....	122
10.1.1	<i>How to Reconfigure an ECU (E Version)</i> .....	122
10.1.2	<i>TOOLBOX™ Software</i> .....	122
10.1.3	<i>Manual Reconfiguration</i> .....	124

# Table of Contents

<b>11</b>	<b>Appendix II</b> .....	<b>126</b>
11.1	E4 ESC End of Line Calibration Procedure .....	126
11.1.1	<i>SAS Calibration</i> .....	126
<b>12</b>	<b>Appendix III</b> .....	<b>137</b>
12.1	E8 ESC End of Line Calibration Procedure .....	137
12.1.1	<i>SAS Calibration</i> .....	137
<b>13</b>	<b>Appendix IV</b> .....	<b>142</b>
13.1	Aftermarket Programming.....	142
13.1.1	<i>Minimum Requirements for Aftermarket Programming</i> .....	142
13.2	Aftermarket Programming Procedures .....	143
13.3	Aftermarket Programming Failure Codes List.....	154

**Edition 1**  
Version 1 (03.2019)  
MM-0112 (en)

This publication is not subject to any update service.  
You will find the current version on the internet at  
<http://www.wabco-na.com>

# Asbestos and Non-Asbestos Fibers



## ASBESTOS FIBERS WARNING

The following procedures for servicing brakes are recommended to reduce exposure to asbestos fiber dust, a cancer and lung disease hazard. Material Safety Data Sheets are available from WABCO.

### Hazard Summary

Because some brake linings contain asbestos, workers who service brakes must understand the potential hazards of asbestos and precautions for reducing risks. Exposure to airborne asbestos dust can cause serious and possibly fatal diseases, including asbestosis (a chronic lung disease) and cancer, principally lung cancer and mesothelioma (a cancer of the lining of the chest or abdominal cavities). Some studies show that the risk of lung cancer among persons who smoke and who are exposed to asbestos is much greater than the risk for non-smokers. Symptoms of these diseases may not become apparent for 15, 20 or more years after the first exposure to asbestos.

Accordingly, workers must use caution to avoid creating and breathing dust when servicing brakes. Specific recommended work practices for reducing exposure to asbestos dust follow. Consult your employer for more details.

### Recommended Work Practices

1. **Separate Work Areas.** Whenever feasible, service brakes in a separate area away from other operations to reduce risks to unprotected persons. OSHA has set a maximum allowable level of exposure for asbestos of 0.1 f/cc as an 8-hour time-weighted average and 1.0 f/cc averaged over a 30-minute period. Scientists disagree, however, to what extent adherence to the maximum allowable exposure levels will eliminate the risk of disease that can result from inhaling asbestos dust. OSHA requires that the following sign be posted at the entrance to areas where exposures exceed either of the maximum allowable levels:

**DANGER: ASBESTOS  
CANCER AND LUNG DISEASE HAZARD  
AUTHORIZED PERSONNEL ONLY  
RESPIRATORS AND PROTECTIVE CLOTHING  
ARE REQUIRED IN THIS AREA.**

2. **Respiratory Protection.** Wear a respirator equipped with a high-efficiency (HEP A) filter approved by NIOSH or MSHA for use with asbestos at all times when servicing brakes, beginning with the removal of the wheels.
3. **Procedures for Servicing Brakes.**
  - a. Enclose the brake assembly within a negative pressure enclosure. The enclosure should be equipped with a HEPA vacuum and worker arm sleeves. With the enclosure in place, use the HEPA vacuum to loosen and vacuum residue from the brake parts.
  - b. As an alternative procedure, use a catch basin with water and a biodegradable, non-phosphate, water-based detergent to wash the brake drum or rotor and other brake parts. The solution should be applied with low pressure to prevent dust from becoming airborne. Allow the solution to flow between the brake drum and the brake support or the brake rotor and caliper. The wheel hub and brake assembly components should be thoroughly wetted to suppress dust before the brake shoes or brake pads are removed. Wipe the brake parts clean with a cloth.
  - c. If an enclosed vacuum system or brake washing equipment is not available, employers may adopt their own written procedures for servicing brakes, provided that the exposure levels associated with the employer's procedures do not exceed the levels associated with the enclosed vacuum system or brake washing equipment. Consult OSHA regulations for more details.
  - d. Wear a respirator equipped with a HEPA filter approved by NIOSH or MSHA for use with asbestos when grinding or machining brake linings. In addition, do such work in an area with a local exhaust ventilation system equipped with a HEPA filter.
  - e. **NEVER** use compressed air by itself, dry brushing, or a vacuum not equipped with a HEPA filter when cleaning brake parts or assemblies. **NEVER** use carcinogenic solvents, flammable solvents, or solvents that can damage brake components as wetting agents.
4. **Cleaning Work Areas.** Clean work areas with a vacuum equipped with a HEPA filter or by wet wiping. **NEVER** use compressed air or dry sweeping to clean work areas. When you empty vacuum cleaners and handle used rags, wear a respirator equipped with a HEPA filter approved by NIOSH or MSHA for use with asbestos. When you replace a HEPA filter, wet the filter with a fine mist of water and dispose of the used filter with care.
5. **Worker Clean-Up.** After servicing brakes, wash your hands before you eat, drink or smoke. Shower after work. Do not wear work clothes home. Use a vacuum equipped with a HEPA filter to vacuum work clothes after they are worn. Launder them separately. Do not shake or use compressed air to remove dust from work clothes.
6. **Waste Disposal.** Dispose of discarded linings, used rags, cloths and HEPA filters with care, such as in sealed plastic bags. Consult applicable EPA, state and local regulations on waste disposal.

### Regulatory Guidance

References to OSHA, NIOSH, MSHA, and EPA, which are regulatory agencies in the United States, are made to provide further guidance to employers and workers employed within the United States. Employers and workers employed outside of the United States should consult the regulations that apply to them for further guidance.



## NON-ASBESTOS FIBERS WARNING

The following procedures for servicing brakes are recommended to reduce exposure to non-asbestos fiber dust, a cancer and lung disease hazard. Material Safety Data Sheets are available from WABCO.

### Hazard Summary

Most recently manufactured brake linings do not contain asbestos fibers. These brake linings may contain one or more of a variety of ingredients, including glass fibers, mineral wool, aramid fibers, ceramic fibers and silica that can present health risks if inhaled. Scientists disagree on the extent of the risks from exposure to these substances. Nonetheless, exposure to silica dust can cause silicosis, a non-cancerous lung disease. Silicosis gradually reduces lung capacity and efficiency and can result in serious breathing difficulty. Some scientists believe other types of non-asbestos fibers, when inhaled, can cause similar diseases of the lung. In addition, silica dust and ceramic fiber dust are known to the State of California to cause lung cancer. U.S. and international agencies have also determined that dust from mineral wool, ceramic fibers and silica are potential causes of cancer.

Accordingly, workers must use caution to avoid creating and breathing dust when servicing brakes. Specific recommended work practices for reducing exposure to non-asbestos dust follow. Consult your employer for more details.

### Recommended Work Practices

1. **Separate Work Areas.** Whenever feasible, service brakes in a separate area away from other operations to reduce risks to unprotected persons.
2. **Respiratory Protection.** OSHA has set a maximum allowable level of exposure for silica of 0.1 mg/m<sup>3</sup> as an 8-hour time-weighted average. Some manufacturers of non-asbestos brake linings recommend that exposures to other ingredients found in non-asbestos brake linings be kept below 1.0 f/cc as an 8-hour time-weighted average. Scientists disagree, however, to what extent adherence to these maximum allowable exposure levels will eliminate the risk of disease that can result from inhaling non-asbestos dust.

Therefore, wear respiratory protection at all times during brake servicing, beginning with the removal of the wheels. Wear a respirator equipped with a high-efficiency (HEPA) filter approved by NIOSH or MSHA, if the exposure levels may exceed OSHA or manufacturers' recommended maximum levels. Even when exposures are expected to be within the maximum allowable levels, wearing such a respirator at all times during brake servicing will help minimize exposure.

3. **Procedures for Servicing Brakes.**
  - a. Enclose the brake assembly within a negative pressure enclosure. The enclosure should be equipped with a HEPA vacuum and worker arm sleeves. With the enclosure in place, use the HEPA vacuum to loosen and vacuum residue from the brake parts.
  - b. As an alternative procedure, use a catch basin with water and a biodegradable, non-phosphate, water-based detergent to wash the brake drum or rotor and other brake parts. The solution should be applied with low pressure to prevent dust from becoming airborne. Allow the solution to flow between the brake drum and the brake support or the brake rotor and caliper. The wheel hub and brake assembly components should be thoroughly wetted to suppress dust before the brake shoes or brake pads are removed. Wipe the brake parts clean with a cloth.
  - c. If an enclosed vacuum system or brake washing equipment is not available, carefully clean the brake parts in the open air. Wet the parts with a solution applied with a pump-spray bottle that creates a fine mist. Use a solution containing water, and, if available, a biodegradable, non-phosphate, water-based detergent. The wheel hub and brake assembly components should be thoroughly wetted to suppress dust before the brake shoes or brake pads are removed. Wipe the brake parts clean with a cloth.
  - d. Wear a respirator equipped with a HEPA filter approved by NIOSH or MSHA when grinding or machining brake linings. In addition, do such work in an area with a local exhaust ventilation system equipped with a HEPA filter.
  - e. **NEVER** use compressed air by itself, dry brushing, or a vacuum not equipped with a HEPA filter when cleaning brake parts or assemblies. **NEVER** use carcinogenic solvents, flammable solvents, or solvents that can damage brake components as wetting agents.
4. **Cleaning Work Areas.** Clean work areas with a vacuum equipped with a HEPA filter or by wet wiping. **NEVER** use compressed air or dry sweeping to clean work areas. When you empty vacuum cleaners and handle used rags, wear a respirator equipped with a HEPA filter approved by NIOSH or MSHA, to minimize exposure. When you replace a HEPA filter, wet the filter with a fine mist of water and dispose of the used filter with care.
5. **Worker Clean-Up.** After servicing brakes, wash your hands before you eat, drink or smoke. Shower after work. Do not wear work clothes home. Use a vacuum equipped with a HEPA filter to vacuum work clothes after they are worn. Launder them separately. Do not shake or use compressed air to remove dust from work clothes.
6. **Waste Disposal.** Dispose of discarded linings, used rags, cloths and HEPA filters with care, such as in sealed plastic bags. Consult applicable EPA, state and local regulations on waste disposal.

### Regulatory Guidance

References to OSHA, NIOSH, MSHA, and EPA, which are regulatory agencies in the United States, are made to provide further guidance to employers and workers employed within the United States. Employers and workers employed outside of the United States should consult the regulations that apply to them for further guidance.

## 1 General Information

### Symbols used in this document

#### **DANGER**

Description of an immediate situation which will result in irreversible injury or death if the warning is ignored.

#### **WARNING**

Description of a possible situation which may result in irreversible injury or death if the warning is ignored.

#### **CAUTION**

Description of a possible situation which may result in irreversible injury if the warning is ignored.

#### **NOTICE**

Description of a possible situation which may result in material damage if the warning is ignored.



Important information, notes and/or tips



Reference to information on the internet

#### 1. Action step

- Action step
- ⇒ Consequence of an action

#### ■ List

- List

 **Note on the use of a tool/WABCO tool**

### How to Obtain Additional Maintenance, Service and Product Information

If you have any questions about the material covered in this publication, or for more information about the WABCO product line, please contact WABCO Customer Care Center at 855-228-3203, by email at [wnacustomercare@wabco-auto.com](mailto:wnacustomercare@wabco-auto.com), or visit our website: [www.wabco-na.com](http://www.wabco-na.com).

# General Information

## WABCO Academy



<https://www.wabco-academy.com/home/>

## WABCO online product catalog



<http://inform.wabco-auto.com/>

## Your direct contact to WABCO

WABCO North America  
WABCO USA LLC  
1220 Pacific Drive  
Auburn Hills, MI 48326  
Customer Care Center: (855) 228-3203  
[www.wabco-na.com](http://www.wabco-na.com)

## 2 Safety Information

### Provisions for a safe work environment

- Only trained and qualified technicians may carry out work on the vehicle.
- Read this publication carefully.
- Follow all warnings, notices and instructions to avoid personal injury and property damage.
- Always abide by the vehicle manufacturer's specifications and instructions.
- Observe all accident regulations of the respective company as well as regional and national regulations.
- The workplace should be dry, sufficiently lit and ventilated.
- Use personal protective equipment if required (safety shoes, protective goggles, respiratory protection and ear protectors).

Read and observe all Danger, Warning and Caution hazard alert messages in this publication. They provide information that can help prevent serious personal injury, damage to components, or both.

#### **WARNING**

To prevent serious eye injury, always wear safe eye protection when you perform vehicle maintenance or service.

#### **WARNING**

Park the vehicle on a level surface. Block the wheels to prevent the vehicle from moving. Support the vehicle with safety stands. Do not work under a vehicle supported only by jacks. Jacks can slip or fall over. Serious personal injury and damage to components can result.

#### **WARNING**

Remove all air pressure from the air system before you disconnect any component, including the desiccant cartridge. Pressurized air can cause serious personal injury.

#### **WARNING**

This product can expose you to chemicals including Nickel, which is known to the State of California to cause cancer and birth defects or other reproductive harm. For more information, go to [www.P65Warnings.ca.gov](http://www.P65Warnings.ca.gov).

#### **CAUTION**

When welding on an ABS- or ABS/ATC-equipped vehicle is necessary, disconnect the power connector from the ECU to prevent damage to the electrical system and ABS/ATC components.



## 3 Introduction

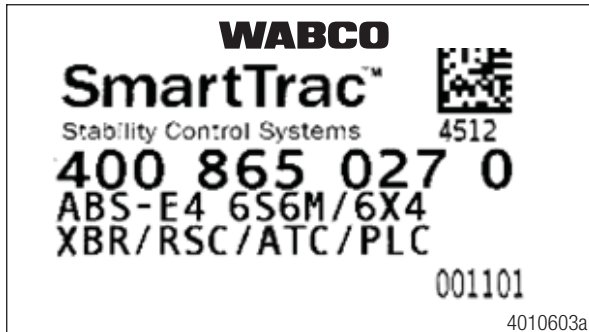
### 3.1 Contents

This manual contains service information for the following systems.

- E version WABCO Anti-Lock Braking System (ABS)
- Automatic Traction Control (ATC)
- Roll Stability Control (RSC)
- Electronic Stability Controls (ESC) for trucks, tractors and buses

The ABS version is marked on the ECU. Figure 3.1. If you cannot identify the ECU version installed on your vehicle, contact the WABCO Customer Care Center at 855-228-3203. This manual contains service and diagnostic information for WABCO Enhanced Easy-Stop™ Trailer ABS with Power Line Carrier (PLC) capability.

Fig. 3.1



#### 3.1.1 For Additional Information

Diagnostic and testing procedures for other ECU versions can be found in the following manuals.

- C version ECUs — Maintenance Manual 28, Anti-Lock Braking Systems (ABS) for Trucks, Tractors and Buses
- D version ECUs — Maintenance Manual 30, Anti-Lock Braking Systems (ABS) for Trucks, Tractors and Buses

Refer to the following manuals for Trailer ABS diagnostics and information.

- Maintenance Manual 33, Easy-Stop™ Trailer ABS
- Maintenance Manual MM-0180, Enhanced Easy-Stop™ Trailer ABS with PLC

#### 3.1.2 Anti-Lock Braking System (ABS)

ABS is a system designed to provide and maintain the best possible traction and steering control during an extreme braking event.

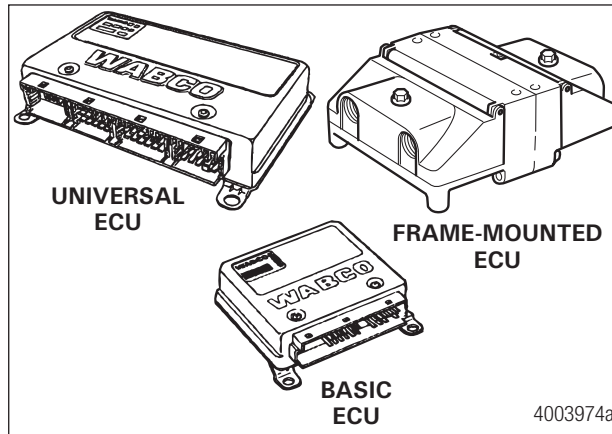
During a potential wheel lock event, the ABS ECU, using information provided by the wheel speed sensors, sends a signal(s) to the appropriate modulator valve(s) to hold, apply or release the brakes as needed. ABS works automatically, the driver does not have to select this feature.

## 3.1.3 System Components

### Electronic Control Unit (ECU)

The ECU is the control center or “brain” of the ABS, RSC and ESC systems. It receives information from the sensors, processes data and sends signals to modulators and active braking valves to achieve different tasks. Depending on the system and vehicle configuration, ECUs are available for cab- or frame-mounted applications and are divided into Basic Cab, Universal Cab, Frame and Advance Frame models. RSC and ESC systems are only available on universal and advance frame ECUs. Figure 3.2.

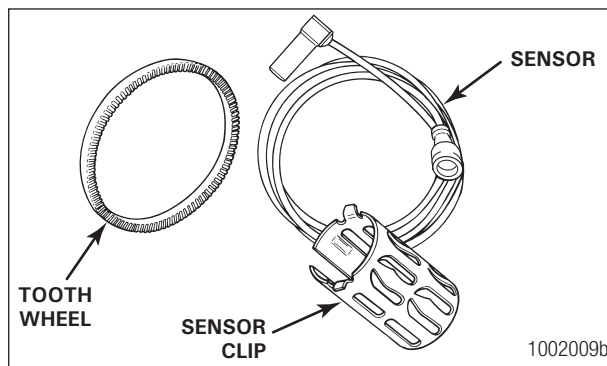
Fig. 3.2



### Wheel Speed Sensing Systems

Wheel speed sensing systems consist of a tooth wheel mounted on the hub or rotor of each monitored wheel and a speed sensor installed with its end against the tooth wheel. The sensor continuously sends wheel speed information to the ECU. A sensor clip holds the sensor in place and against the tooth wheel. Figure 3.3.

Fig. 3.3



The type of axle determines sensor mounting location.

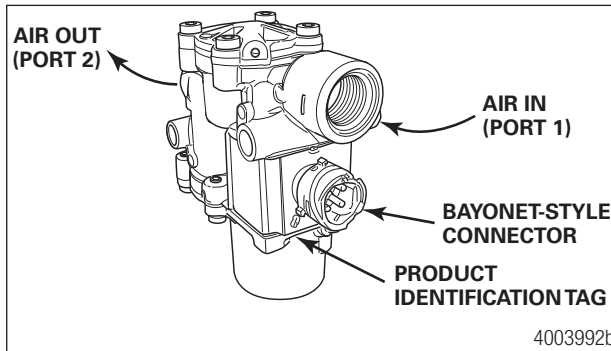
- Steering axle sensors are installed in the steering knuckle or in a bolted-on bracket.
- Drive axle sensors are mounted in a block attached to the axle housing or in a bolted-on bracket.

Check the wheel speed sensors for correct alignment and adjustment. Apply lubricant to the sensor and sensor clip whenever wheel-end maintenance is performed. Make sure tooth wheels are free of contaminants. Refer to Section 5 and Section 6 for more information.

## Pressure Modulator Valves

A modulator valve controls air pressure to an affected wheel-end brake during an ABS, RSC or ESC event to reduce speed and prevent wheel lock up. Modulator valves are also used during ATC events to properly gain traction on the affected wheel end. Figure 3.4.

Fig. 3.4



A modulator valve is usually located on a frame rail or cross member near the brake chamber or as part of a valve package. A valve package combines two modulator valves, a service relay (Figure 3.5) or quick release valve (Figure 3.6), and depending on the vehicle configuration, an active braking valve (ABV).

Fig. 3.5

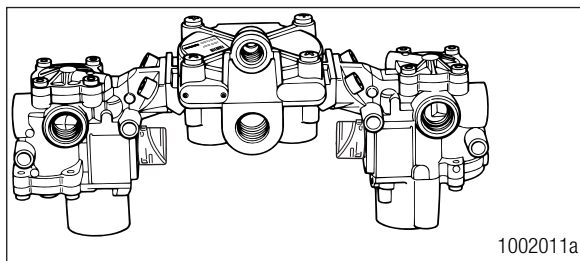
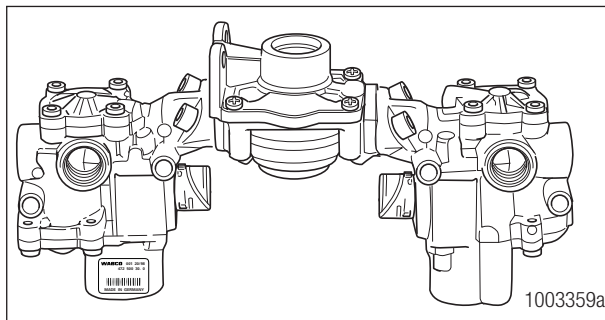


Fig. 3.6



### Easy Listening Tip!

! To ensure the ABS valves are working — just listen! Figure 3.7.

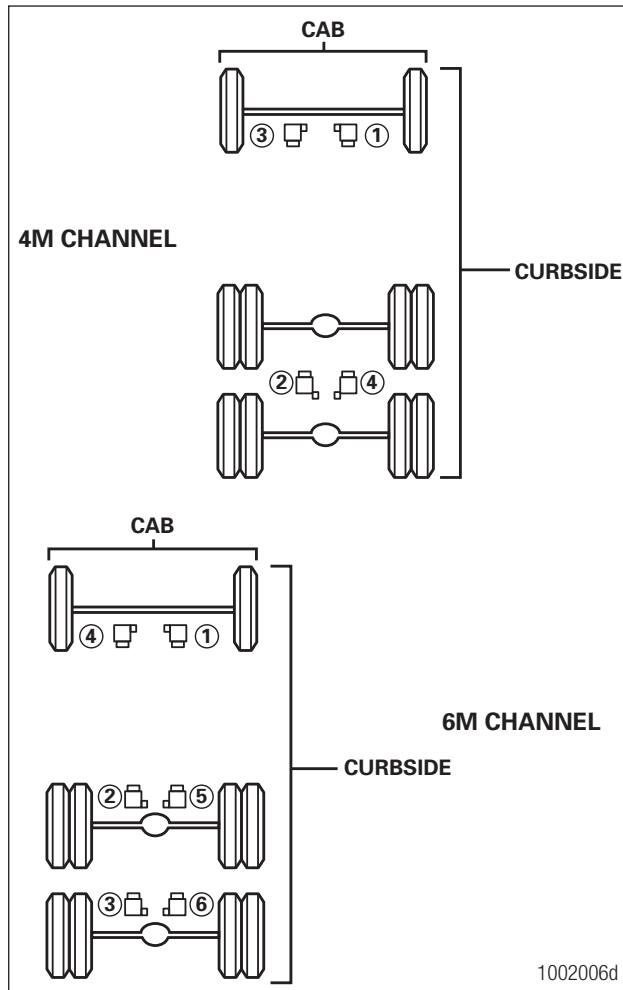
### WARNING

Park the vehicle on a level surface. Block the wheels to prevent the vehicle from moving. Support the vehicle with safety stands. Do not work under a vehicle supported only by jacks. Jacks can slip or fall over. Serious personal injury and damage to components can result.

1. Turn on the ignition.
2. Wait for the ABS indicator lamp to come on.

3. Listen for the valves to click or puff/chuff air in the order shown in Figure 3.7.

Fig. 3.7

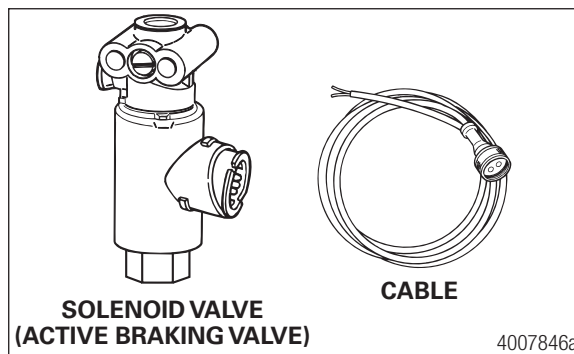


In previous versions of ABS, the valves are cycled diagonally. Diagonal cycling does not occur with E version ABS.

## Active Braking Valves (ABV)

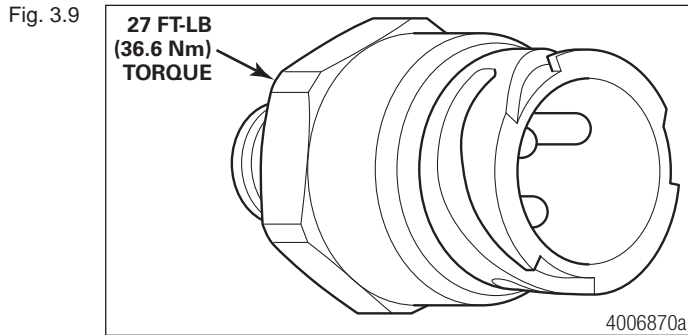
Active Braking Valves, sometimes referred to as ABVs or 3/2 valve, are solenoid valves used for active braking during ATC, RSC or ESC events. Depending on system configurations, ABVs can be located in the front axle braking system, rear axle braking system and/or the trailer service brake system. Figure 3.8.

Fig. 3.8



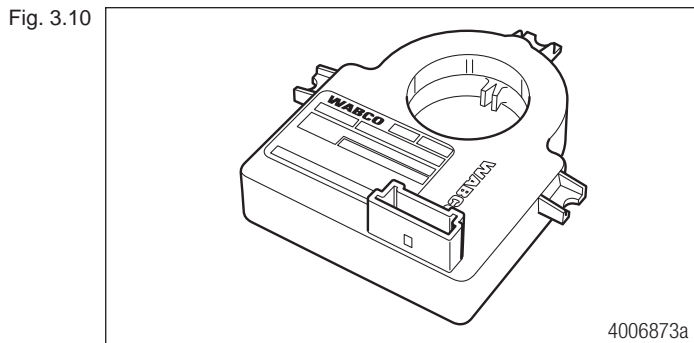
## Brake Pressure Sensor (BPS)

The Brake Pressure Sensor or BPS is part of the RSC, ESC and HSA system. It provides the system with the driver's brake demand. The sensor can be located in the primary or secondary delivery circuit depending on the application. Figure 3.9.



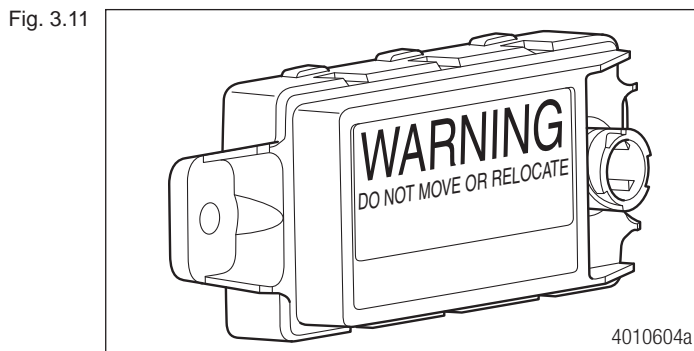
## Steering Angle Sensor (SAS)

The Steering Angle Sensor (SAS) is part of the ESC system. The SAS delivers the driver's steering input (steering wheel position) to the ECU using a dedicated ESC system internal data link. The ECU supplies the sensor with voltage and ground. The SAS must be calibrated using diagnostic tools whenever it is replaced, or when any vehicle steering components are replaced or adjusted. Refer to Section 10. Figure 3.10.



## Electronic Stability Control (ESC) Module

The ESC module is part of the ESC system. It measures the vehicle yaw rate as well as vehicle lateral acceleration. The ESC module includes part of the ESC control algorithm. It exchanges data with the ECU via the ESC system internal data link. The ECU supplies the module with voltage and ground. The ESC module must be initialized by diagnostic tools whenever the ECU or the ESC module is replaced. Refer to Section 10. Figure 3.11.



## **Trailer Modulator Valve**

In some stability control applications, an additional modulator valve (the same as what is used for ABS modulation) will be located in the trailer control line downstream of the 3/2 solenoid valve used to control the trailer.

## **Off-Road ABS Switch**

On some vehicles, an off-road ABS switch can be included. The off-road ABS function improves vehicle control and helps reduce stopping distances in off-road conditions or on poor traction surfaces such as loose gravel, sand and dirt.

## **ATC Switch**

A vehicle manufacturer might offer an ATC switch to control the ATC function. Depending on the vehicle ECU configuration for the switch, there are two function options.

- Deep snow and mud option
- ATC momentary override option

Refer to Section 4 for more information regarding these features.

## **Blink Code Switch**

A vehicle manufacturer might offer a Blink Code switch to obtain simple troubleshooting information. Refer to Section 5 for more information about Blink Codes.

## **3.2 System Configuration**

The system configuration is defined by the number of wheel end sensors and modulator valves. There are three common system configurations used with E version ECUs. Refer to Section 7 for more system configurations.

- 4S/4M (4 wheel speed sensors, 4 modulator valves)
- 6S/4M (6 wheel speed sensors, 4 modulator valves)
- 6S/6M (6 wheel speed sensors, 6 modulator valves)

# Introduction

Each system configuration can have features such as ATC, HSA, RSC or ESC. See Figure 3.12 and Figure 3.13 for an example.

Fig. 3.12

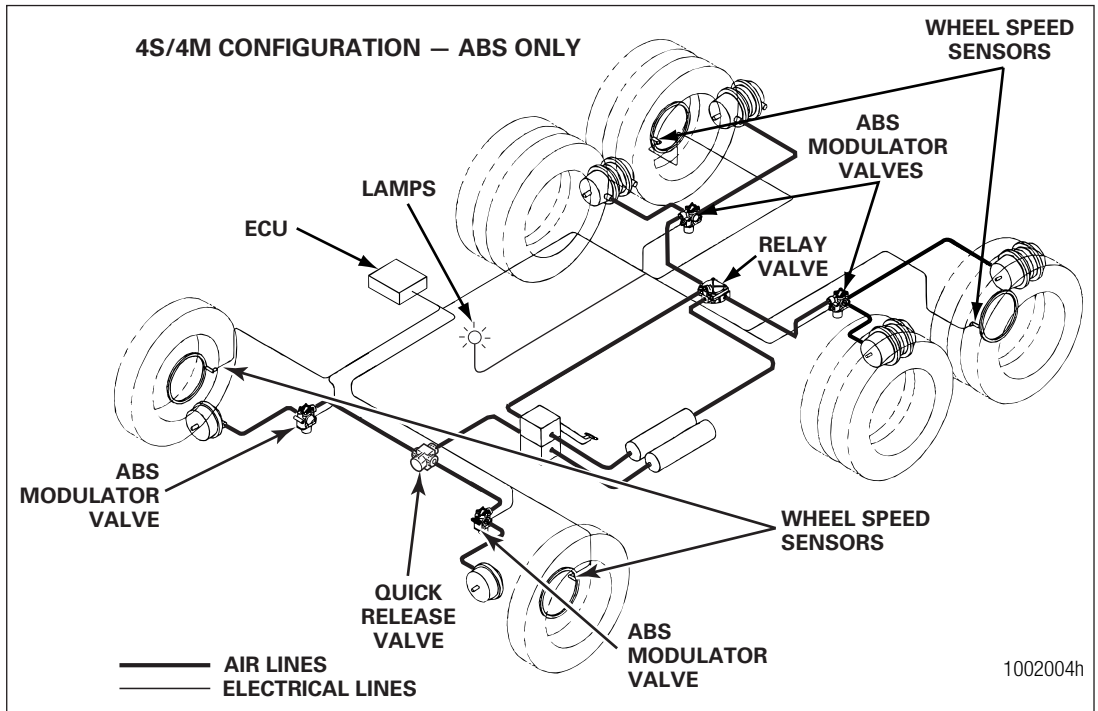
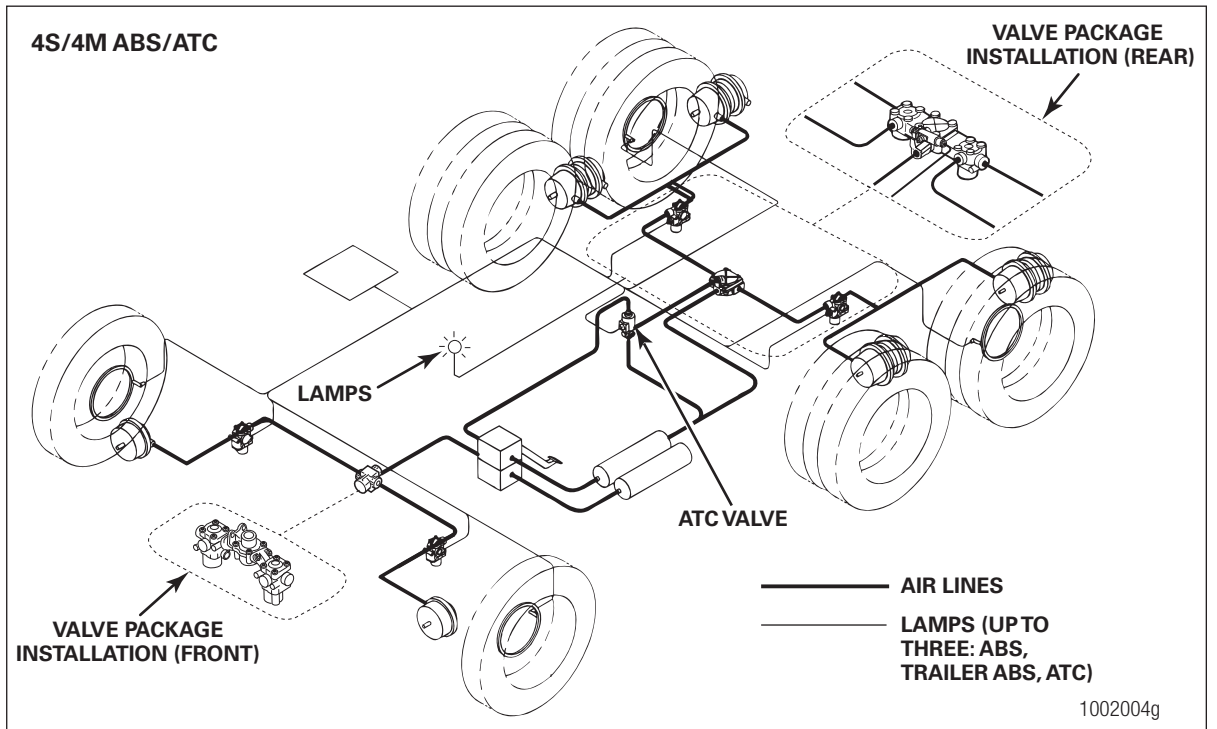


Fig. 3.13



## 4 Stability and Safety Enhancement Systems

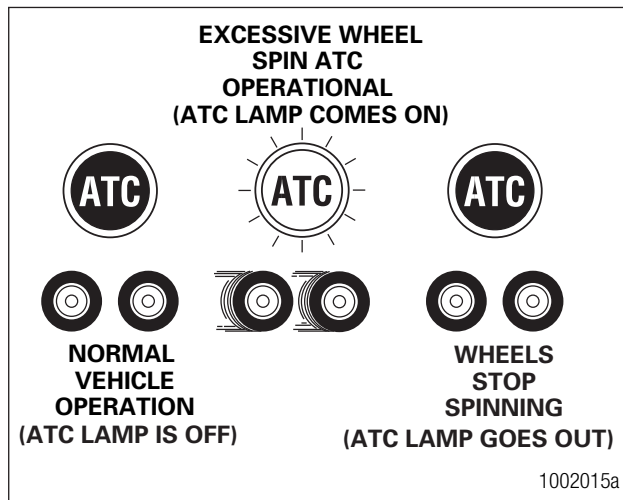
### 4.1 ATC

Automatic Traction Control is available as an option on all E version ECUs and is standard on most. ATC helps improve traction in low traction road conditions. ATC reduces the potential of jackknifing caused by excessive wheel spin during acceleration or in curves. ATC works automatically in two different ways.

- A. When one drive wheel is spinning at a different speed than the other, ATC momentarily applies the brake until traction is regained.
- B. When both drive wheels are spinning on a poor-traction surface, ATC automatically reduces engine power to attain optimum tire-to-road traction.

ATC will automatically turn on and off. Driver input is not required to turn this feature on. If the vehicle experiences a traction control event, the ATC indicator lamp will come on, indicating ATC is active. The light turns off when the event has ended. Figure 4.1.

Fig. 4.1



Some vehicle manufacturers may refer to ATC as Anti-Spin Regulation (ASR).

If ATC is installed, there will be an indicator lamp on the vehicle dash or instrument panel marked ATC, ASR, or potentially Stability Control, depending on the application.

### 4.2 ATC Components

ATC uses the base ABS components plus an active braking valve that can be installed with individual modulator valves, or installed as part of the rear valve package.

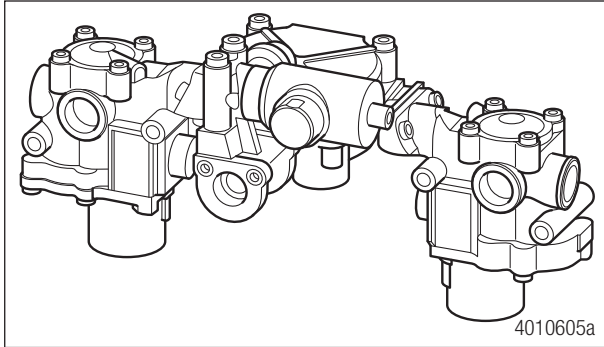
When installed with individual modulator valves, the active braking valve is mounted on the frame or cross member, near the rear of the vehicle.



# Stability and Safety Enhancement Systems

When it is part of the rear valve package, the active braking valve is attached to the relay valve. Figure 4.2.

Fig. 4.2



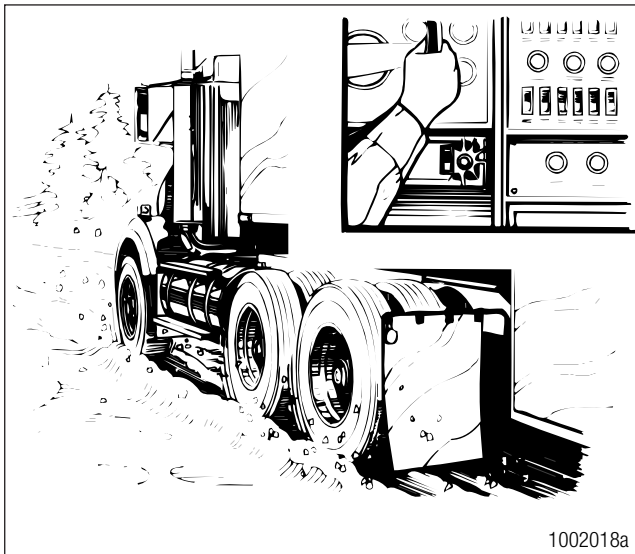
## ATC Switch

If the vehicle manufacturer offers an ATC switch to control the ATC functionality, there are two common types of configuration settings as follows.

- **Deep snow and mud option:** This function helps to increase available traction on extra soft surfaces like snow, mud or gravel, by slightly increasing the permissible wheel spin.
- **ATC momentary override option:** This function allows the driver to momentarily disable/override ATC for the duration of the ignition cycle.

When either option is in use, the ATC indicator lamp blinks continuously to inform the driver. Figure 4.3.

Fig. 4.3



Switch and lamp locations as well as ATC switch configuration will vary depending on the vehicle make and model. Please check with the vehicle manufacturer for correct information.

Here's how the ATC switch works.

Driver Action	System Response	Function	
		Active	Not Active
Press ATC switch	ATC lamp blinks continuously	X	
Press ATC switch again	ATC lamp stops blinking		X



Turning off the ignition will also deactivate either ATC function.

## Roll Stability Control (RSC)

Roll stability control is an option designed to assist drivers in managing the conditions that may result in vehicle rollovers. When RSC senses conditions that may result in a rollover, it may reduce engine torque, engage the engine retarder, apply pressure to the drive axle brakes and may modulate the trailer brakes to slow the vehicle down. Depending on the application and vehicle configuration, the steer axle brakes may be applied as well.

Similar to ATC, RSC works automatically. The driver does not have to select this feature. Unlike ATC, RSC cannot be turned off by the driver.

## RSC Components

RSC uses many of the same components used by ABS/ATC including modulator valves, active braking valves and wheel speed sensors. RSC ECUs are different from ABS ECUs as they contain an internal accelerometer that measures and updates the lateral acceleration of the vehicle and compares it to a critical threshold at which rollover may occur.

Depending on the vehicle manufacturer, RSC ECUs have orientation on the XX/YY or ZZ axis. For correct operation and the best performance, verify the ECU is correctly leveled and securely mounted. Figure 4.4, Figure 4.5 and Figure 4.6.

Fig. 4.4

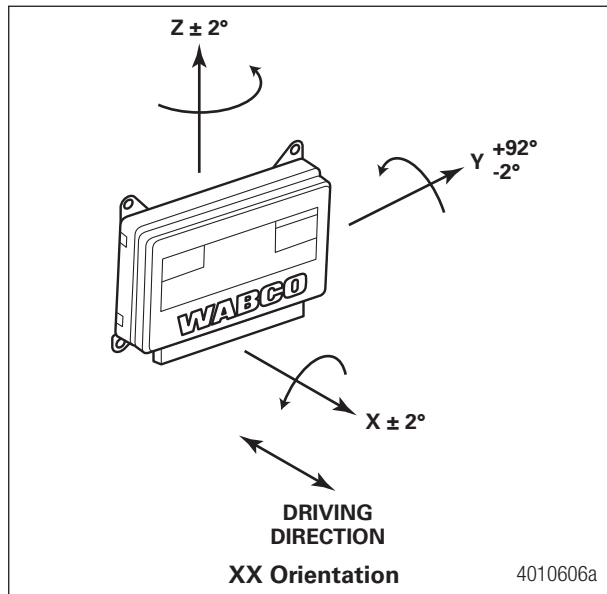


Fig. 4.5

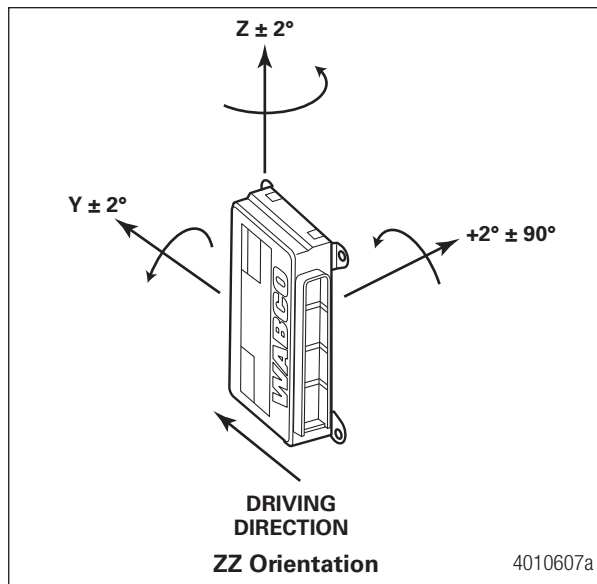
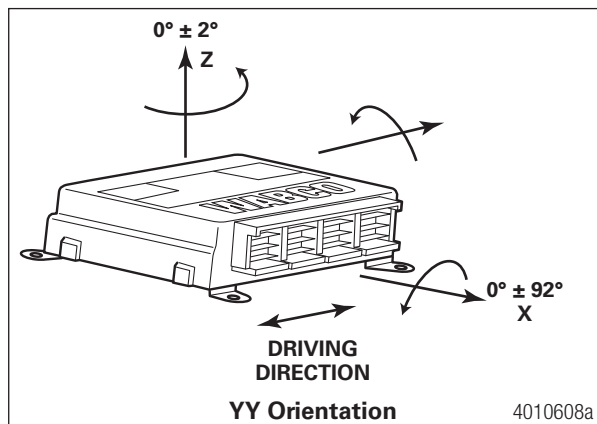


Fig. 4.6



Certain vehicle configurations can have an additional active braking valve for trailer service brakes, an active braking valve for front axle brakes and a brake pressure sensor.

The active braking valve for trailer braking is a stand-alone valve that is not available as part of the ABS/ATC valve package. Depending on the application, a modulator valve may be located downstream of the solenoid valve. Figure 4.7.

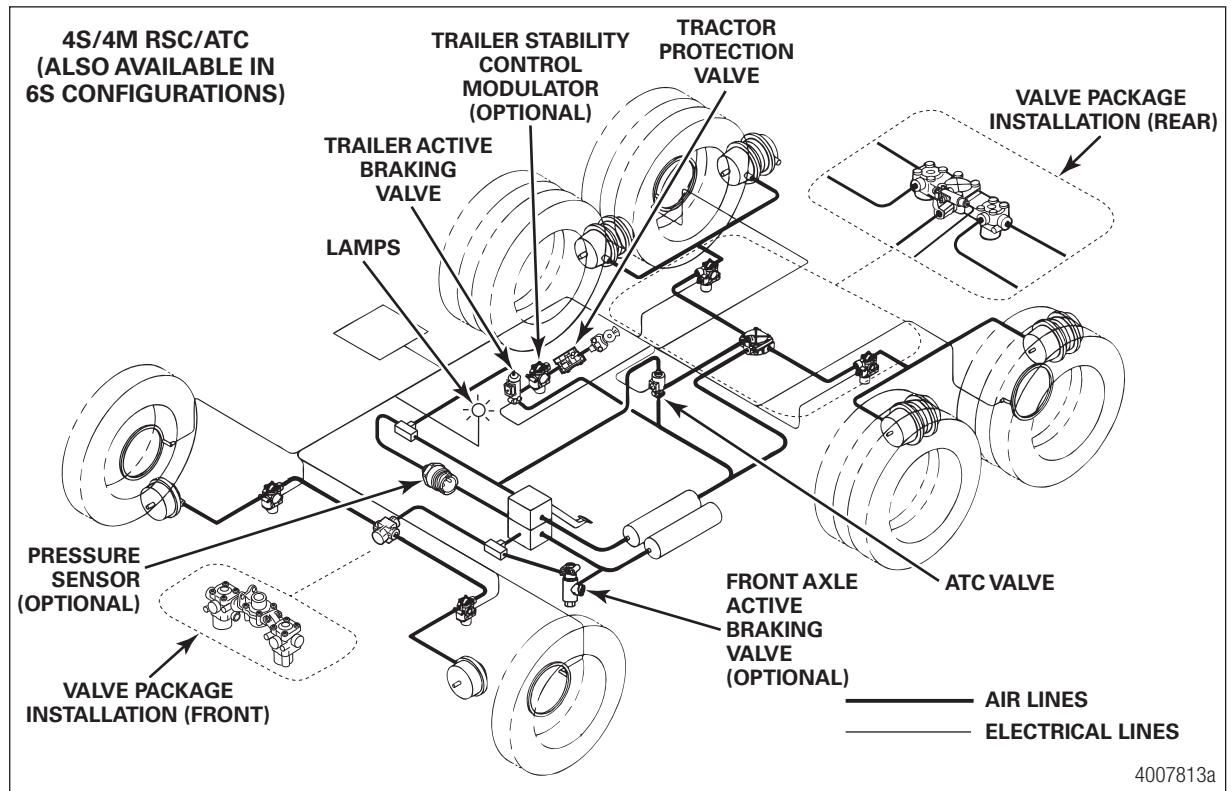
## WARNING

RSC helps reduce the tendency of the vehicle to roll over when cornering or changing directions, however, IT CAN NOT PREVENT ALL ROLLOVERS FROM OCCURRING.

# Stability and Safety Enhancement Systems

When operating the vehicle, always use safe driving techniques. The driver is always the most important factor in safe vehicle operation.

Fig. 4.7



## Electronic Stability Control (ESC)

Electronic Stability Control (ESC) combines the rollover prevention of Roll Stability Control (RSC) with directional stability in order to keep the vehicle traveling on its intended path by providing spinout and drift out control.

Like RSC, ESC is automatic. It becomes active when the system senses imminent directional or roll instabilities, often before the driver is aware. You will notice a difference in the vehicle when stability control is functioning, but you should continue to drive as normal and provide any additional needed corrections.

You may again notice a reduction in engine torque and additional deceleration from the retarder, if so equipped. You also may notice individual or all brakes applying depending on whether the vehicle is in a roll or directional control event.

## ESC Components

ESC is built from the ABS platform and uses many of the same components as ATC and RSC. An active braking valve to control the front axle brakes, a pressure sensor, an ESC module and a Steering Angle Sensor (SAS) are required in addition to the components necessary for RSC. Figure 4.8 and Figure 4.9. These components are also described in the following section.

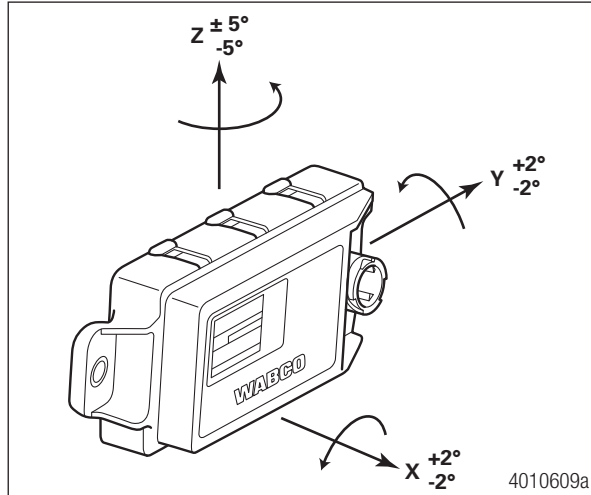
Note that for ESC applications on a non-towing vehicle (straight truck), the trailer active braking valve is not required.

The ESC ECU is available in both Cab- and Frame-mounted versions. The Universal Cab-Mounted ECU with ESC is an upgraded version of the current Universal ABS ECU with a fourth connector containing the necessary inputs/outputs required for full stability control. The Frame-Mounted Advance ECU with ESC is an upgraded version of the current ABS Frame-Mounted ECU with six additional pins on both the X1 and X2 connectors of the ECU. These ECUs support 4S4M, 6S4M and 6S6M vehicle configurations and are compatible with 12V electrical systems. For pinout information, refer to Section 8 of this manual.

# Stability and Safety Enhancement Systems

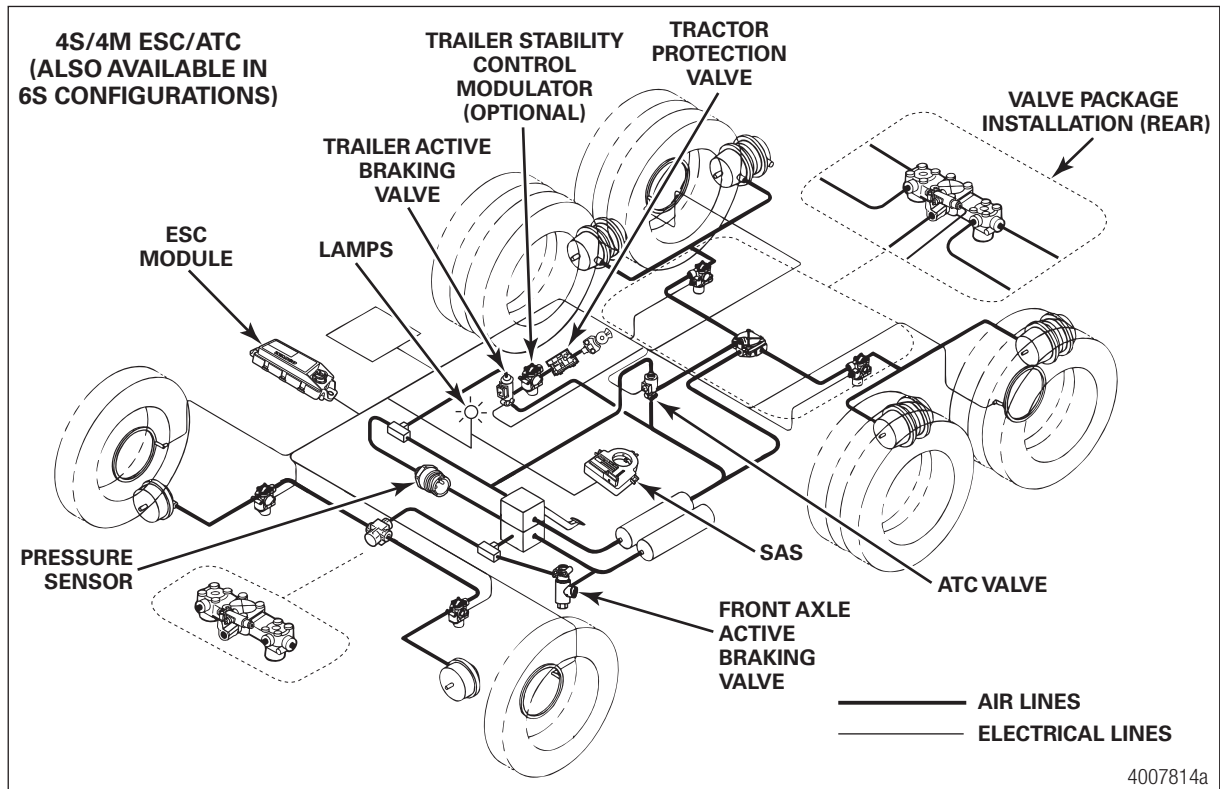
The ESC ECU contains parameter settings which are specific to a vehicle configuration validated by WABCO Engineering. It is imperative that the correct ECU is installed on your vehicle in service. Contact WABCO or your respective vehicle OEM with any questions regarding ESC ECU. Figure 4.8 and Figure 4.9.

Fig. 4.8



ESC modules are installed by the OEM close to the vehicle center of gravity. Depending on the vehicle manufacturer, the ESC module might face towards the front of the vehicle or rear. For correct operation and the best performance, verify the ESC module is correctly leveled and securely mounted according to OEM specifications. Do not move the module to a different location as this will affect the system performance.

Fig. 4.9



## **Hill Start Aid (HSA)**

Hill Start Aid (HSA) supports select automated manual transmissions in reducing/totally eliminating the rolling back of the vehicle while launching on a grade. When requested from the transmission, HSA holds pressure in the service brakes of all axles of the towing vehicle when the vehicle is standing still. HSA will hold pressure for a maximum of three seconds following full release of the brake pedal. Communication between the transmission and the ECU takes place via the J1939 data link.

HSA grade threshold parameters may be modified in the Transmission ECU. These parameters must be reviewed with the transmission manufacturer prior to making any modifications in order to ensure safe operation.

## **HSA Components**

HSA is available on ABS ECUs with E4.4 software revision or higher. Same as ESC, HSA is built from the ABS platform and uses many of the same components as ATC and RSC. HSA uses the front axle active braking valve as well as the rear active braking valve to help maintain the pressure trapped during HSA activation.

A pressure sensor provides the system with the driver's brake demand. The measured pressure is used by HSA to set the trapped pressure and/or activate the HSA function.

The vehicle manufacturer can provide an HSA switch multiplexed through the dashboard or hard wired for momentary HSA deactivation.

An HSA lamp, either hard wired or multiplexed, provides the driver with a visual indication of system deactivation and/or active fault. If the lamp is hard wired, it must be an incandescent lamp or LED with a resistor to prevent the ECU from setting a fault code.

A failure detected on any of these components will lead to no HSA availability. To troubleshoot the HSA, refer to Section 5 – Diagnostics, Troubleshooting and Testing.

## **Drag Torque Control**

The ABS ECU has the ability to send a message to the engine to increase engine RPM to prevent drive axle lock-up, if the vehicle is on a downhill grade and in the incorrect gear.

## **Lift Axle Capability**

Certain six sensor ABS ECUs with ATC allow third axle sensors to be installed on a lift axle. These ECUs will not log a fault for the axle being in the raised position while the vehicle is moving.

## 5 Diagnostics, Troubleshooting and Testing

### 5.1 General

### 5.2 Maintenance Information

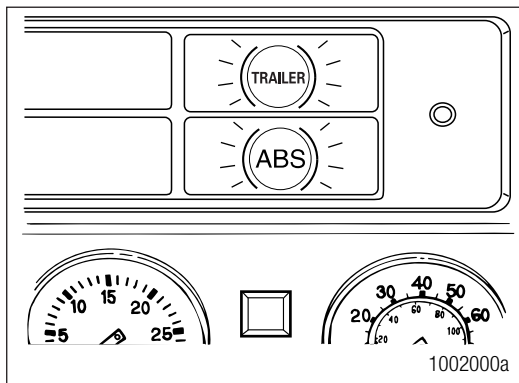
There is no regularly scheduled maintenance required for the WABCO ABS, ATC, RSC or ESC systems. However, this does not change current vehicle maintenance requirements.

- **Lamp Check:** To ensure the ABS tractor lamp is operating, drivers should check the lamp every time the vehicle is started. When the vehicle is started, the ABS lamp should come on momentarily. If it does not come on, it could mean a burned-out bulb.
- **ABS Wheel Speed Sensors:** Check the wheel speed sensor adjustment and lubricate the sensor and sensor clip whenever wheel-end maintenance is performed. Use only WABCO-recommended lubricant, as specified in Section 4.

#### ABS Indicator Lamp

Two ABS indicator lamps, one for tractor and one for trailer, let drivers know the status of the system. Figure 5.1. The tractor ABS lamp is also used to display tractor blink code diagnostics. The location of the ABS indicator lamps varies depending on the make and model of the vehicle.

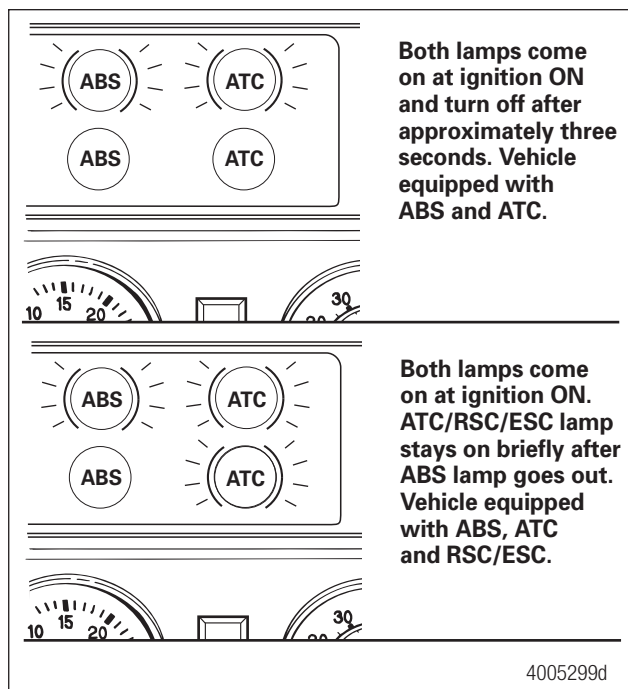
Fig. 5.1



ATC and RSC/ESC functions may share the same dash indicator lamp. Therefore, understanding how the ABS and ATC/RSC/ESC lamps work is very important.

- If the vehicle is equipped with ATC, but not RSC/ESC, when the ignition is turned to the ON position, the ABS and ATC lamps will light for approximately three seconds, and then both lamps will turn off simultaneously. Figure 5.2.
- If the vehicle is equipped with ATC and RSC/ESC, when the ignition is turned to the ON position, the ABS and ATC/RSC/ESC will both light but the ATC/RSC/ESC lamp will stay lit briefly after the ABS lamp goes out.

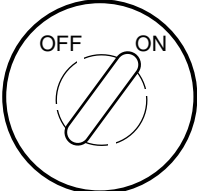
Fig. 5.2



The ABS indicator lamp works as follows:



If the ECU senses a tractor ABS fault during normal vehicle operation, the ABS indicator lamp will come on and stay on.

 1002005a	Ignition On	Normal Operation	ABS lamp comes on at ignition momentarily for a bulb check, then goes out.	System is OK.
		After servicing ABS components	ABS lamp does not go out at ignition.	When vehicle is driven at speeds above 4 mph (6 km/h), lamp goes out. System is OK.
		Off-road ABS operation. Refer to the off-road ABS information in this section.	ABS lamp flashes during vehicle operation.	The vehicle's normal ABS function is being modified due to road conditions.
		Existing fault or lamp issue	ABS lamp does not go out at ignition.	Lamp does not go out at speeds above 4 mph (6 km/h) — a fault may exist in the ABS system or lamp is permanently shorted.



## Diagnostics



Blink code diagnostics are not compatible with E8 software versions.

Use any of the following methods to diagnose E version ECUs:

- WABCO TOOLBOX™ Software, a PC-based diagnostic and testing program that runs in Microsoft Windows® XP, Vista, Windows 7, Windows 8 and Windows 10 operating system.
- Blink Codes. Refer to the information in this section.
- OEM Diagnostic Displays. Refer to the vehicle operator's manual.

If you have any questions about system diagnostics, please contact the WABCO Customer Care Center at 855-228-3203.

### TOOLBOX™ Software Diagnostics

For complete instructions for installing and using TOOLBOX™ Software, refer to the User's Manual posted on [wabco-na.com](http://wabco-na.com).

WABCO TOOLBOX™ Software provides computer-based diagnostic capabilities for the complete range of WABCO vehicle control systems. The program provides the following functions:

- Displays both static (e.g., ECU number) and dynamic (e.g., RPMs) information from the system under test.
- Displays both active and stored system faults, as well as the appropriate repair instructions.
- Activates system components to verify system integrity, correct component operation and installation wiring.

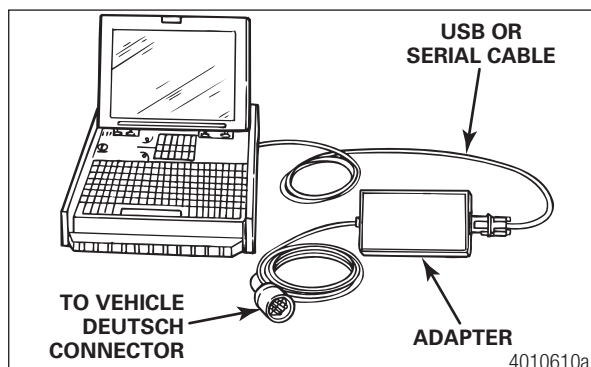


For E8 software versions, TOOLBOX™ 12 or higher is required.

To display E version ABS, RSC, ESC or HSA faults:

1. Connect the computer to the vehicle:
  - Attach the USB/serial cable from your computer's USB or serial port to the adapter.
  - Attach the Deutsch diagnostic cable from the adapter to the vehicle. Figure 5.3.

Fig. 5.3



2. Select the TOOLBOX™ Software icon from the desktop or from the Windows® Start Menu to display the Main Menu.

### 3. Adapter Selection

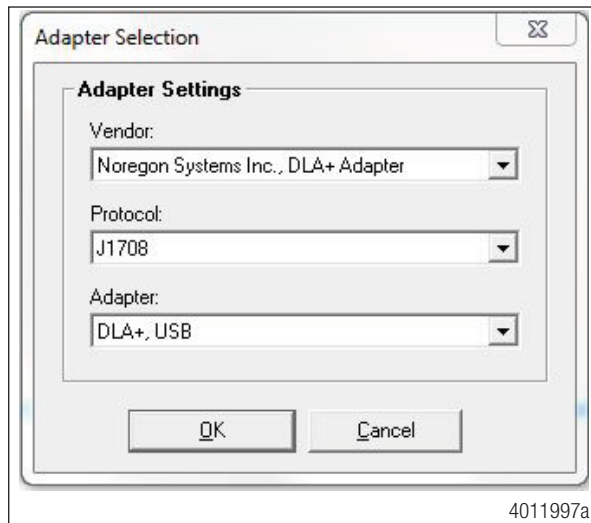
Verify the TOOLBOX™ Software is set for the device and communication protocol that will be used.

To access “Adapter Selection” for TOOLBOX™ Software 11 or newer, click on “Utilities” from the main TOOLBOX™ page or under “System Setup” in “J1707/PLC TOOLBOX” from the main TOOLBOX page. Figure 5.5.

To access “Comport Settings” for TOOLBOX™ Software versions prior to TOOLBOX™ Software 11, click on “System Setup” from the main TOOLBOX™ page. Figure 5.6.

Make sure the “Vendor:” and “Adapter:” drop-downs are set for the device being used and set the “Protocol:” drop-down to J1708 OR J1939 according to the system you will be communicating through, and click “OK”. Figure 5.4.

Fig. 5.4



When switching between J1939 and J1708 communications with TOOLBOX™ Software 11, the vehicle ignition must be cycled between sessions to correctly communicate with the ECU.



TOOLBOX™ Software must be connected to the vehicle and the vehicle ignition must be ON in order to display information. If unable to communicate with the ECU:

- Verify device and data link connections are secure.
- Verify the device is RP1210A compliant and that the comport settings (Vendor, Protocol, Adapter) in TOOLBOX™ Software are correct.
- Verify the device software and firmware is up to date.
- Check all the powers and grounds coming to the ECU including load testing.
- Check J1587 circuit at the ECU and the data link connector.
- Check J1939 circuit at the ECU and the data link connector.

# Diagnostics, Troubleshooting and Testing

4. Depending on the software version used, there will be two options to communicate with the vehicle:
- If using TOOLBOX™ 11 or higher and a vehicle with Software ECU E4.4b or higher, diagnostics over J1939 communications can be possible. Figure 5.5.



E8 software versions will only communicate over J1939.

- J1708 communications are possible with any TOOLBOX™ Software version and any D or E Version ECU. Figure 5.6.

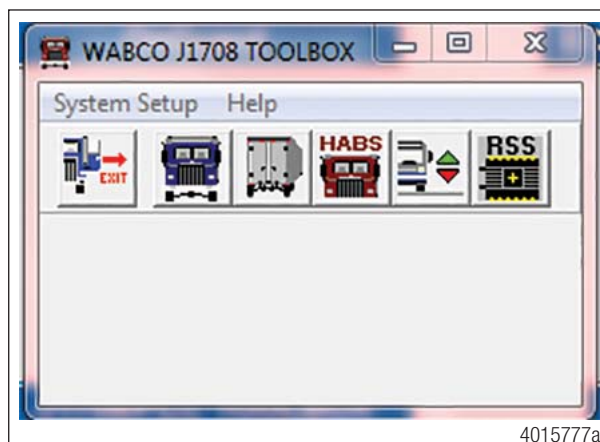


When switching between J1939 and J1708 communications, vehicle ignition must be cycled between sessions to correctly communicate with ECU.

Fig. 5.5



Fig. 5.6



# Diagnostics, Troubleshooting and Testing

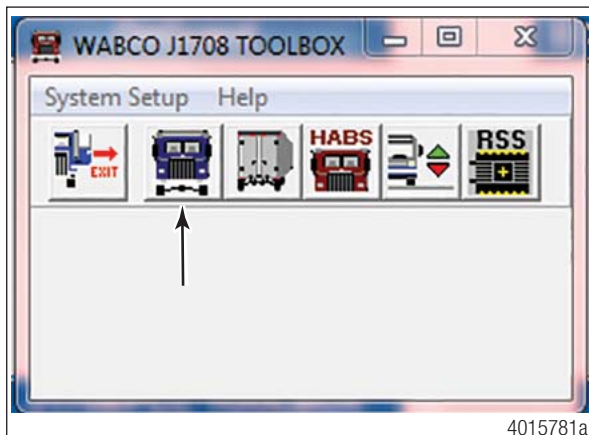
In the Main Menu, select J1939 Tractor ABS or J1708 TOOLBOX™, then Tractor ABS. The ABS Main Screen will appear. Figure 5.7, Figure 5.8 and Figure 5.9.

Fig. 5.7



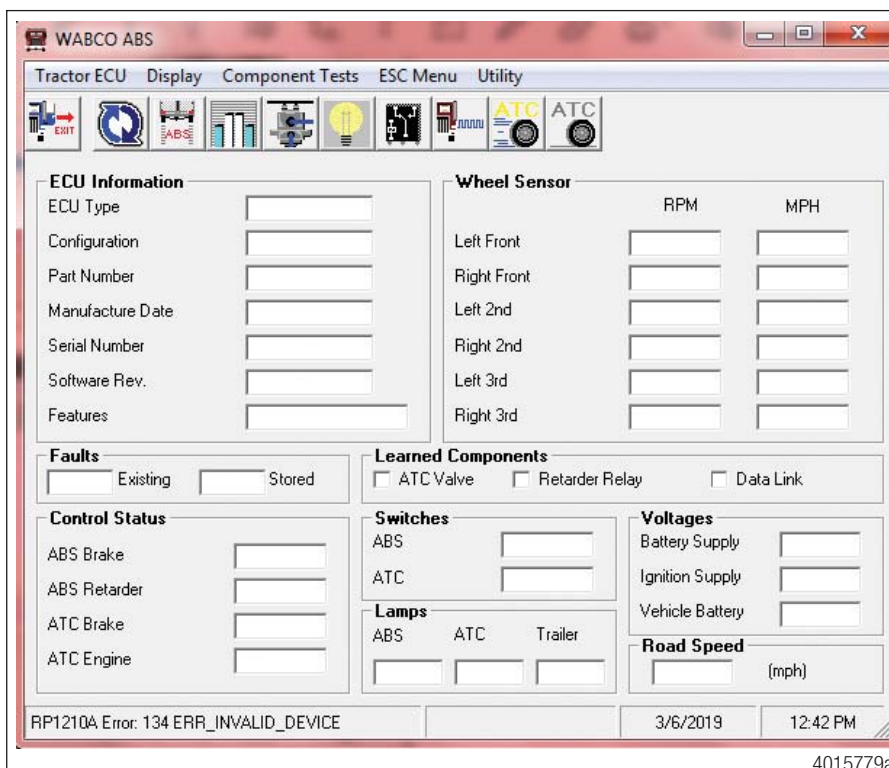
4010613a

Fig. 5.8



4015781a

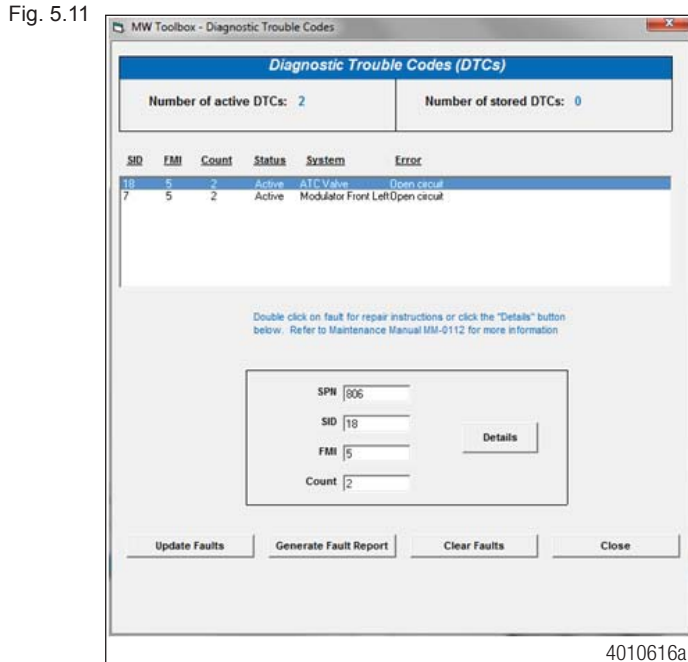
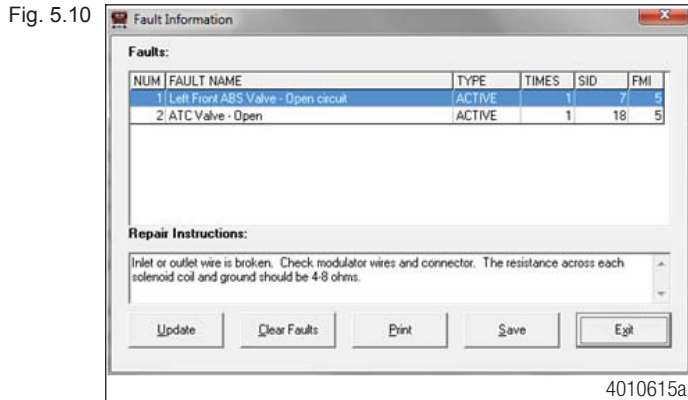
Fig. 5.9



4015779a

# Diagnostics, Troubleshooting and Testing

6. Select Display from the top menu.
7. From the pull-down menu, select Faults or Diagnostic Trouble Codes. This will open the Fault Information screen. Figure 5.10 and Figure 5.11.



8. A description of the fault, the number of times the fault occurred, the system identifier (SID), the failure mode (FMI) and Suspect Parameter Number (SPN) are all displayed in the fault information window. Basic repair instructions for each fault are also provided. More detailed information about SID and FMI troubleshooting and repair is provided in the following section as well as the SID FMI table.

Double-clicking on the fault, or clicking on **Details**, will provide troubleshooting and detailed repair instructions. TOOLBOX™ Software version 11 also provides links to the appropriate system schematic which are also provided in this maintenance manual.



If you are using TOOLBOX™ Software version 11, Internet Explorer is required to load files containing repair information, maintenance manual and schematics.

Faults that may occur after the screen is displayed will not appear until screen is manually updated. Use the **Update** button to refresh the fault information table.

After making the necessary repairs, use the **clear faults** button to clear the fault. Use the **Update** button to refresh the fault information table and display the new list of faults. Some faults may require vehicle ignition to be cycled and vehicle speed over 4 mph (6.4 kph) to clear them.

Use the **Save** or **Print** button to save or print the fault information data.



If the TOOLBOX™ Software is unable to communicate with the ECU, verify the system is self-testing when the key is cycled.

**If the system is not self-testing:** Check all the powers and grounds connecting to the ECU including load testing.

**If the system is self-testing:** Check the following.

- Verify the ECU part number.
- Verify device and data link connections are secure.
- Verify the device is RP1210A compliant and that the comport settings (Vendor, Protocol, Adapter) in TOOLBOX™ Software are correct.
- Verify the device software and firmware is up-to-date.

## Blink Code Diagnostics (ABS Only)

### Definitions

Blink codes can be used to obtain fault information for ABS components, however, due to the advanced level of complexity of ESC, RSC and HSA, it is recommended to use WABCO TOOLBOX™ Software for detailed troubleshooting of any of these systems.

Before using blink code diagnostics, you should be familiar with a few basic terms. If you used previous versions of WABCO's blink code diagnostics, review these definitions to identify major changes.

**ABS Indicator Lamp:** This lamp serves two purposes: it alerts drivers to an ABS tractor fault and it is used during diagnostics to display the blink code.

**Blink Code:** A series of blinks or flashes that describe a particular ABS fault or condition. Codes are displayed in two-digit blink codes.

**Blink Code Cycle:** Two sets of flashes with each set separated by a one-and-one-half second pause. Blink codes are defined in the blink code identification information in this section.

**Blink Code Switch:** A momentary switch that activates blink code diagnostic capabilities. Switch types and locations vary, depending on the make and model of the vehicle.

**Clear:** The process of erasing faults from the ECU.

**Diagnostics:** The process of using blink codes to determine ABS faults.

**Fault:** An ABS malfunction detected and stored in memory by the WABCO ECU. System faults may be Active or Stored.

**Active Fault:** A condition that currently exists in the ABS; for example: A sensor circuit malfunctions on the left front steering axle. An active fault must be repaired before it can be cleared from memory — and before you can display additional blink code faults.

**Stored Fault:** There are two types of stored faults:

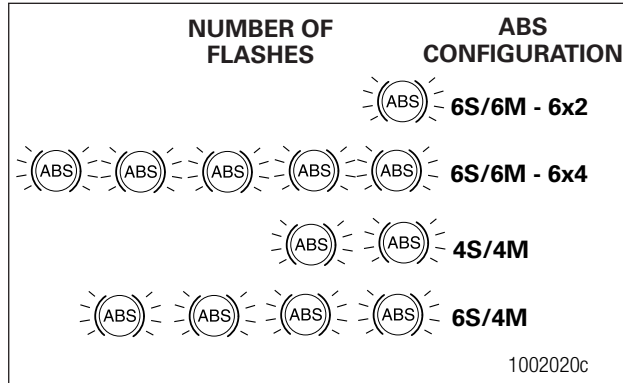
- A. A repaired active fault that **has not been cleared** from the ECU.
- B. A fault that occurred but **no longer exists**. For example, a loose wire that makes intermittent contact. Because stored faults are not currently active, they do not have to be repaired before they can be cleared from memory.

# Diagnostics, Troubleshooting and Testing

WABCO recommends you keep a record of these faults for future reference.

**System Configuration Code:** One-digit code displayed during the clear mode. Blink codes for common ABS configurations are shown in Figure 5.12.

Fig. 5.12



## Clear Mode

To erase faults from the ECU, you must be in the clear mode. To enter the clear mode, press and hold the blink code switch for at least three seconds, then release.

If the system displays eight quick flashes followed by a system configuration code, the clear was successful. Stored ABS faults have been cleared from memory.

If you do not receive eight flashes, there are still active faults that must be repaired before they can be cleared.



The clear mode is also used to disable the ATC function.

TABLE A: TROUBLESHOOTING WITH BLINK CODE DIAGNOSTICS

Procedure	System Response	Action
<b>Diagnostic Mode</b>		
<b>Step I.</b> <b>Turn ignition ON.</b>	Possible responses: ABS indicator lamp comes on momentarily then goes out, indicating System OK. ABS indicator lamp does not light, indicating possible wiring fault or burned-out bulb. ABS indicator lamp stays on, indicating:	No recognizable active faults in the ABS. No action required. Inspect wiring. Inspect bulb. Make necessary repairs.
	<ul style="list-style-type: none"> <li>■ Fault, or faults, in the system.</li> <li>■ Sensor fault during last operation.</li> <li>■ Faults cleared from ECU, but vehicle not driven.</li> <li>■ ECU disconnected.</li> <li>■ Power or ground wiring issue.</li> </ul>	Continue with blink code diagnostics. <b>(Go to Step II.)</b> Continue with blink code diagnostics. <b>(Go to Step II.)</b> Drive vehicle — lamp will go out when vehicle reaches 4 mph (6 km/h). Connect ECU. Check harness powers and grounds at the ECU.

# Diagnosics, Troubleshooting and Testing

Procedure	System Response	Action
<b>Diagnostic Mode</b>		
<b>Step II.</b> <b>Press and hold Blink CODE Switch for one second, then release.</b>	ABS indicator lamp begins flashing two-digit blink code(s).	Determine if fault is active or stored: <b>Active Fault:</b> Lamp will repeatedly display one code. <b>Stored Fault:</b> Lamp will display code for each stored fault then stop blinking. Faults will be displayed <b>one time only</b> .
<b>Step III.</b> <b>Count the flashes to determine the blink code.</b>	First Digit: 1-8 flashes, Pause (1-1/2 seconds) Second Digit: 1-6 flashes, Pause (4 seconds)	Find definition for blink code on blink code chart.
<b>Step IV.</b> <b>Turn ignition OFF.</b> <b>Repair and record faults.</b>	Active Fault  Stored Fault	Make the necessary repairs. Repeat Step 1, Step II and Step III until System OK, code (1-1) received. Record for future reference. <b>NOTE:</b> Last fault stored is first fault displayed.
<b>Clear Mode</b>		
<b>Step V.</b> <b>Turn ignition ON.</b> <b>Clear Faults from memory:</b> <b>Press and hold blink code switch for at least three seconds, then release.</b>	ABS indicator lamp flashes eight times.  Eight flashes not received.	All stored faults successfully cleared. Turn ignition OFF. Active faults still exist, repeat Step I through Step V.



## Blink Code Illustrations

Fig. 5.13

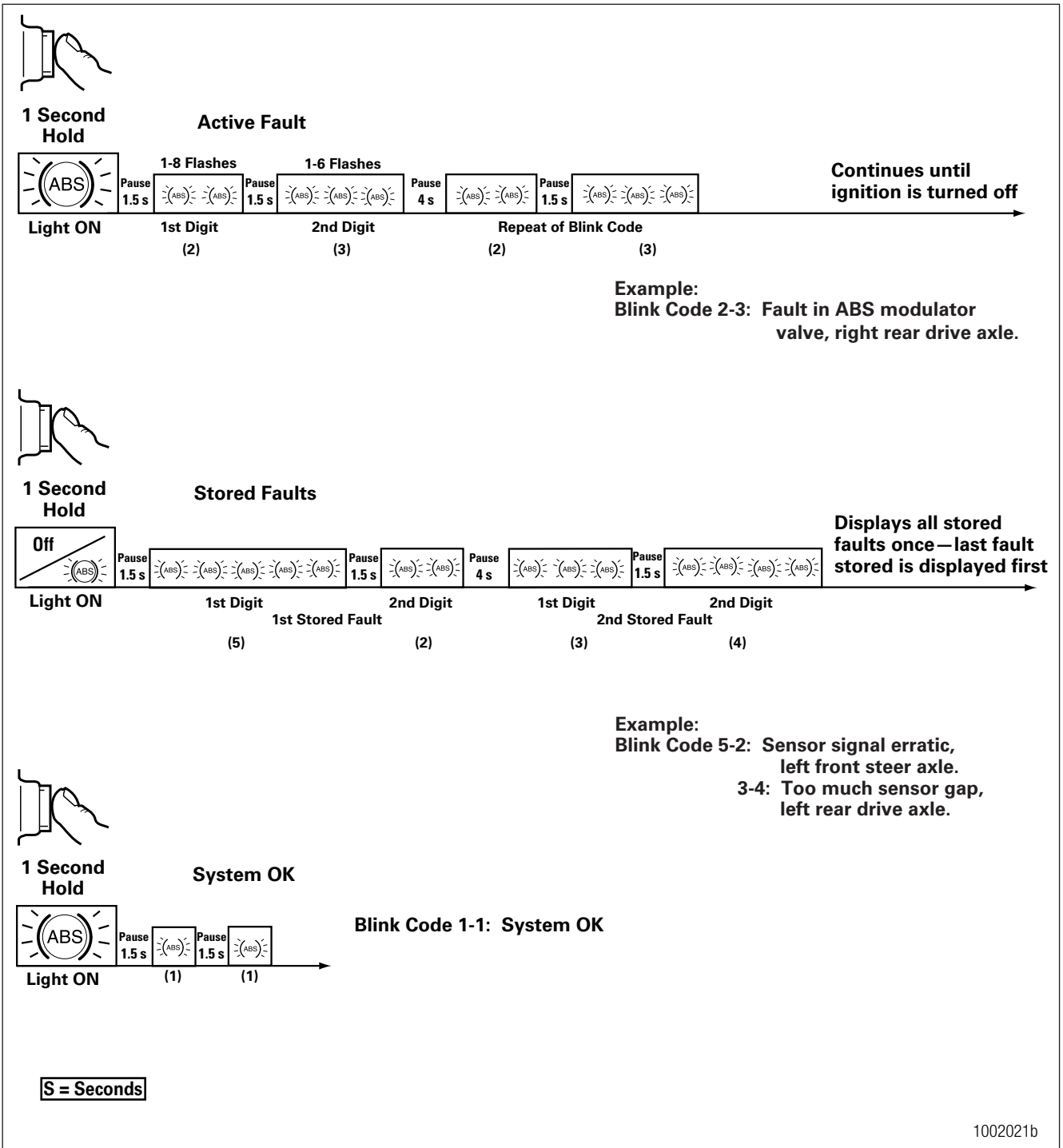
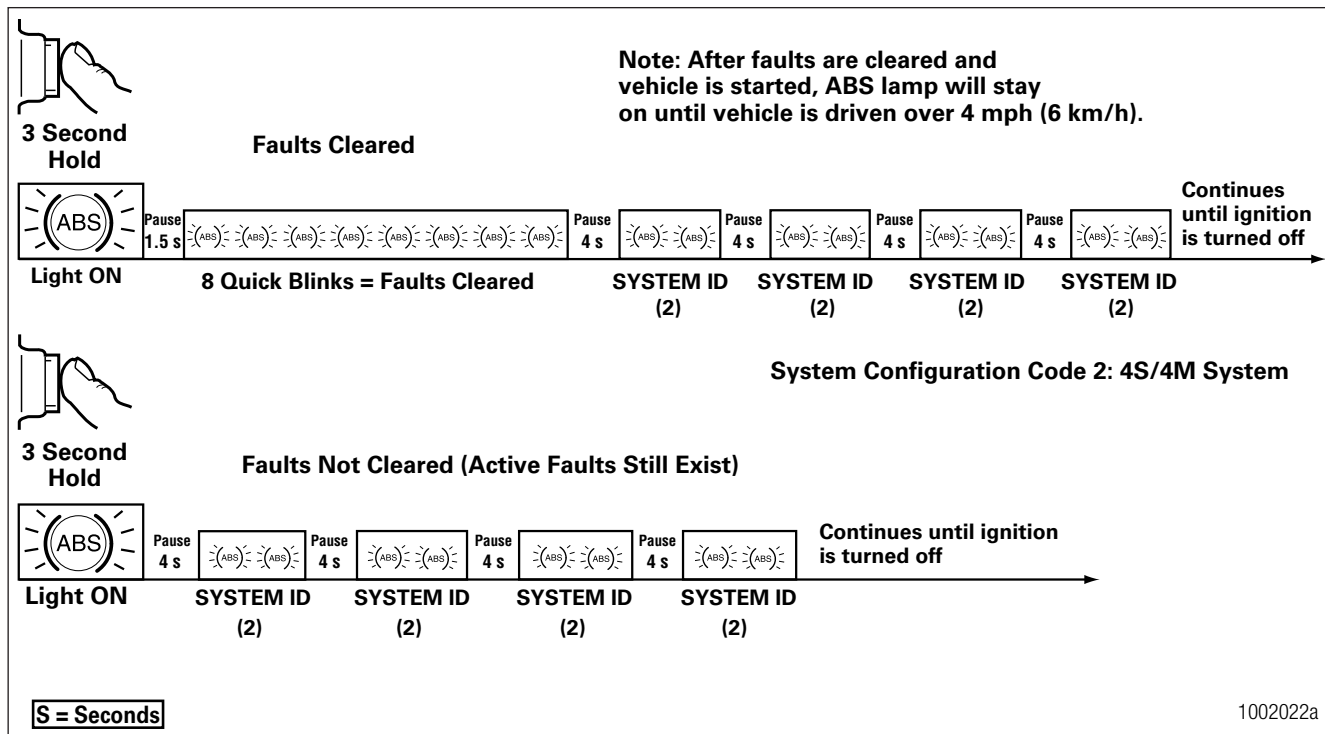


Fig. 5.14



If the vehicle does not have a blink code switch, a test lead/jumper wire may be installed as a temporary blink code switch.

**For Cab-mounted ECUs:** Back probe pin 15 of the X1 connector to ground for 1 second to obtain codes or back probe pin 15 for 3 seconds to clear codes.

**For Frame-mounted ECUs with all 12 pin connectors:** Back probe pin 10 of the X1 connector to ground for 1 second to obtain codes or back probe pin 10 for 3 seconds to clear codes.

**For Frame-mounted ECUs with all 18 pin connectors:** Back probe pin 15 of the X1 connector to ground for 1 second to obtain codes or back probe pin 15 for 3 seconds to clear codes.

# Diagnostics, Troubleshooting and Testing

## Blink Code Conditions

When using blink code diagnostics, the following conditions could occur:

**TABLE B: BLINK CODE CONDITIONS**

Condition	Reason	Action
<b>ABS indicator lamp does not come on at ignition.</b>	Loose or burned-out bulb.	Check bulb. Check connections. Make necessary repairs.
	Voltage not within acceptable range (9.5-14.0 volts) (18-32 for 24V system).	Check connections. Measure voltage. Make necessary repairs.
<b>Cannot use blink code diagnostics. ABS indicator lamp will not go off when blink code is activated.</b>	Switch not held for correct length of time: 1 Second — Diagnostics Mode 3 Seconds — Clear All Mode	Repeat procedure, hold switch for correct length of time.
	Incorrect or faulty wiring.	Inspect and repair wiring.
	Fault not erased from ECU after report.	Repeat procedure until System OK code received.
<b>Eight flashes not received after blink code switch pressed for at least three seconds, then released.</b>	Active faults still exist.	Identify active faults, then make necessary repairs. Turn ignition OFF, then repeat Blink Code Diagnostics.

## Blink Code Identification

Use the following information to identify the blink code:

First Digit (Type of Fault)	Second Digit — Specific Location of Fault
1 No faults	1 No faults
2 ABS modulator valve 3 Too much sensor gap 4 Sensor short or open 5 Sensor signal erratic/tire size 6 Tooth wheel	1 Right front steer axle (curb side) 2 Left front steer axle (driver's side) 3 Right rear drive axle (curb side) 4 Left rear drive axle (driver's side) 5 Right rear/additional axle (curb side) 6 Left rear/additional axle (driver's side)
7 System function	1 J1939 or proprietary ESC CAN. Several sensors out of adjustment 2 ATC 3/2 valve 3 Retarder relay or third brake relay such as drive line brake, exhaust brake or engine brake 4 ABS indicator lamp 5 ATC configuration 6 Trailer active braking valve or front axle active braking valve 7 Brake pressure sensor 8 Tire pressure monitoring
8 ECU	1 Low power supply 2 High power supply 3 Internal fault 4 System configuration error 5 Ground 6 RSC accelerometer or ESC module

## 5.2.1 Testing

### 5.2.1.1 Wheel Speed Sensor Testing

#### Sensor Adjustment

- Push the sensor in until it contacts the tooth wheel.
- Do not pry or push sensors with sharp objects.
- Sensors will self-adjust during wheel rotation.

# Diagnostics, Troubleshooting and Testing

## Electrical Checks

- Check wheel speed sensor by itself for resistance.
- Check ECU harness and sensor together for resistance. Figure 5.15 and Figure 5.16.
- Verify no change in resistance or open circuit between sensor by itself and through harness.
- Check harness by itself for any shorts to battery and shorts to ground.
- Measurements should read as follows:

Location	Measurement
Between sensor leads	900-2000 ohm
At ECU harness pins with sensor connected	Same as above, no more than 1 ohm difference
ECU harness by itself for DC voltage or ground	No continuity
Sensor output voltage	At least 0.2 volt AC at 30 rpm

**i** Sensor resistance can change with temperature. All readings should be taken at the same time and before vehicle is driven.

Fig. 5.15

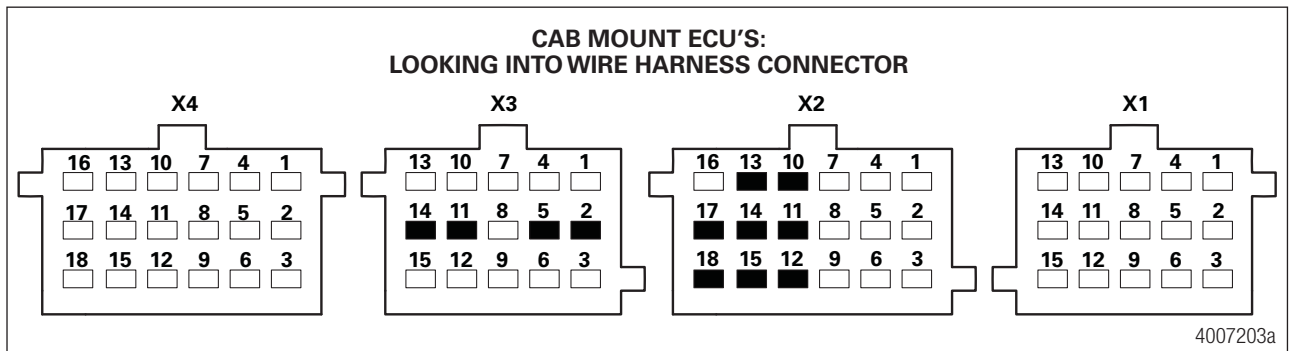
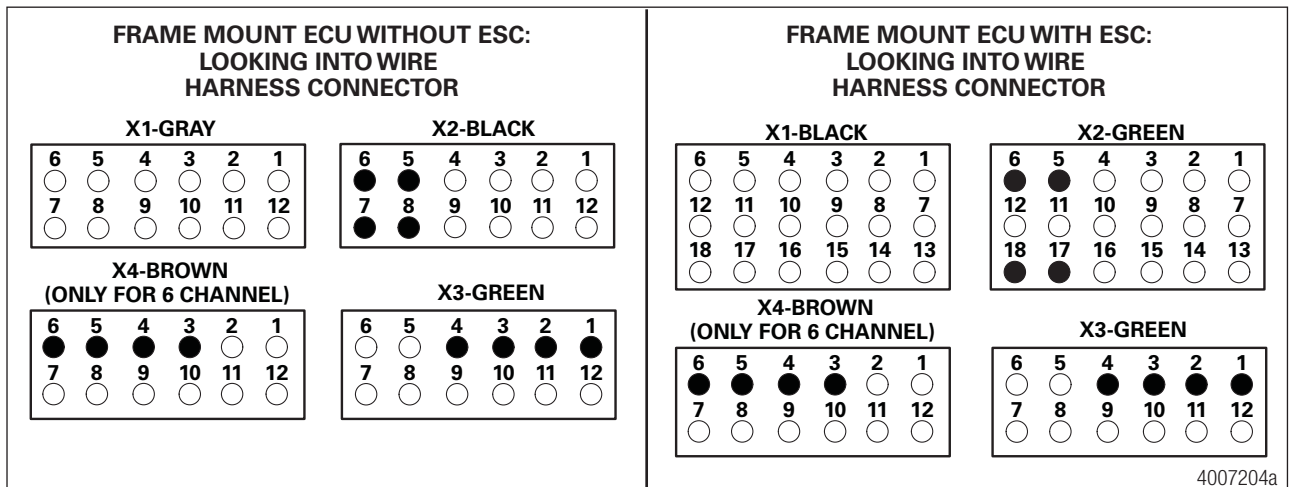


Fig. 5.16



ECU	Sensor	Connector	Pins
Cab-Mounted Universal with ESC, Universal or Basic	LF	X2-18 pin	12 and 15
	RF	X2-18 pin	10 and 13
	LR	X2-18 pin	11 and 14
	RR	X2-18 pin	17 and 18
	LR (3rd axle)	X3-15 pin	2 and 5
	RR (3rd axle)	X3-15 pin	11 and 14
Frame-Mounted Non-ESC	LF	X2-Black	7 and 8
	RF	X2-Black	5 and 6
	LR	X3-Green	1 and 2
	RR	X3-Green	3 and 4
	LR (3rd axle)	X4-Brown	3 and 4
	RR (3rd axle)	X4-Brown	5 and 6
Frame-Mounted With ESC	LF	X2-Green	17 and 18
	RF	X2-Green	5 and 6
	LR	X3-Green	1 and 2
	RR	X3-Green	3 and 4
	LR (3rd axle)	X4-Brown	3 and 4
	RR (3rd axle)	X4-Brown	5 and 6

## 5.2.1.2 Modulator Valve Testing

### Electrical Checks

- Check modulator valve by itself for resistance. Figure 5.17 and Figure 5.18.
- Check ECU harness and modulator valve together for resistance. Figure 5.19 and Figure 5.20.
- Verify no change in resistance or open circuit between valve by itself and through harness.
- Check harness by itself for any shorts to battery and shorts to ground.

Measurements should read as follows:

Location	Measurement
Inlet valve pin to Ground	4.0-9.0 ohm for 12V system 11.0-21.0 ohm for 24V system
Outlet valve pin to Ground	4.0-9.0 ohm for 12V system 11.0-21.0 ohm for 24V system
At ECU harness pins with modulator valve connected	Same as above, no more than 1 ohm difference
ECU harness by itself for battery voltage or ground	No continuity



If resistance exceeds 9.0 ohm for 12V system (21.0 ohm for 24V system), verify the reading was not taken between the inlet and outlet. If the correct pins were tested, clean the electrical contacts at the modulator and retest.

Fig. 5.17

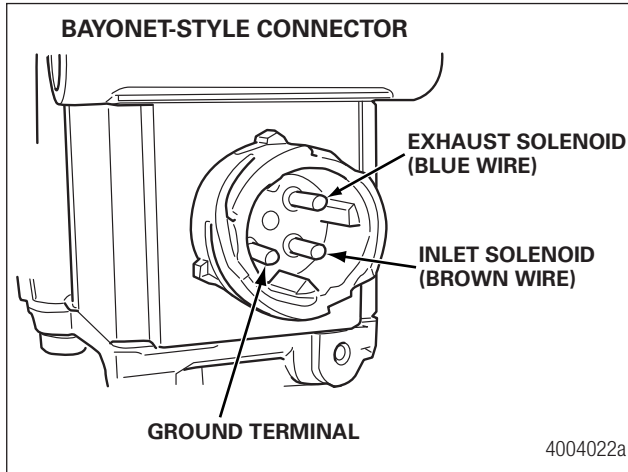


Fig. 5.18

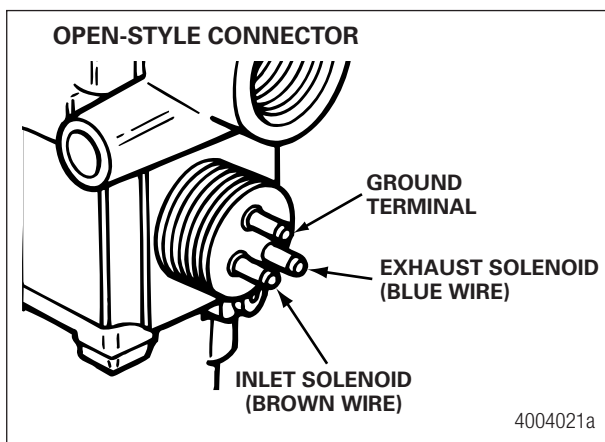
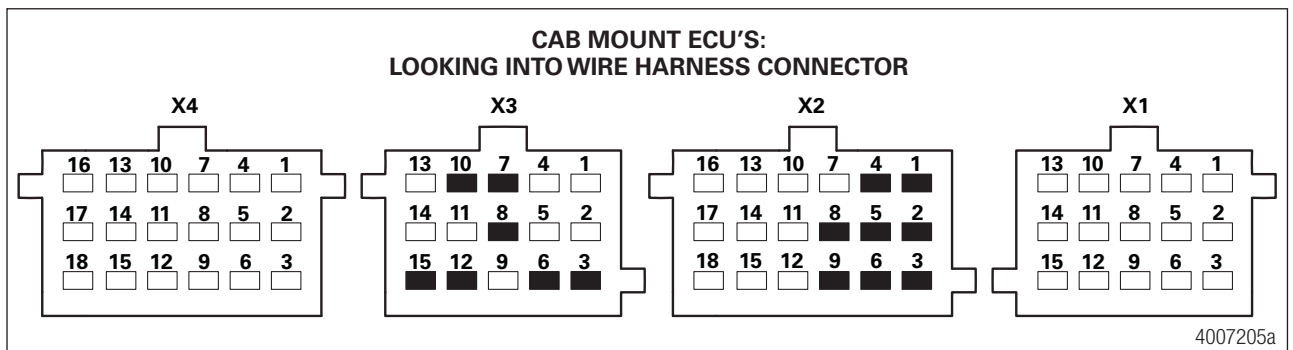
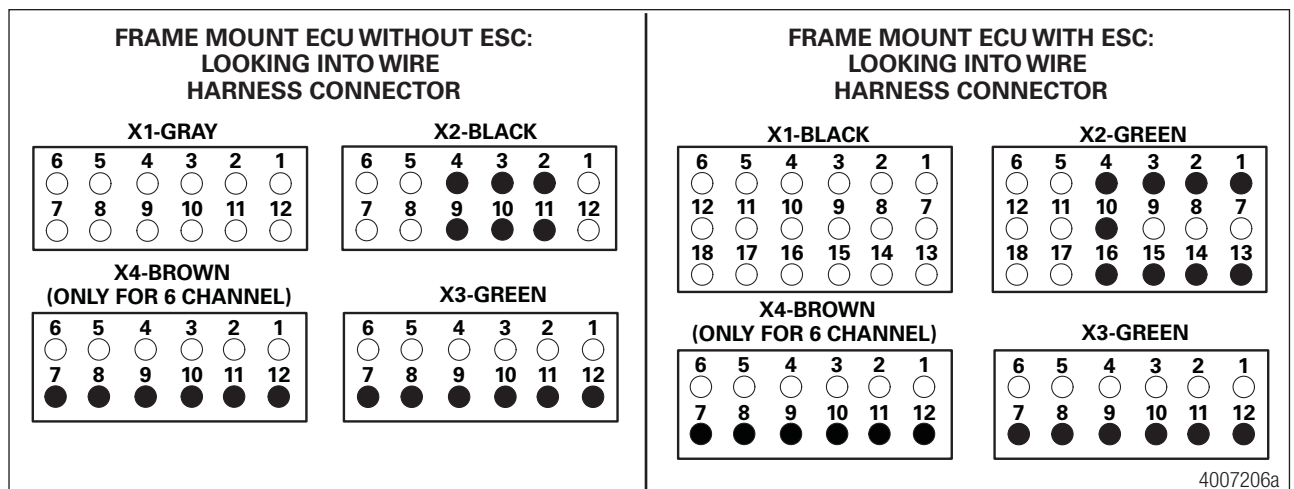


Fig. 5.19



ECU	Modulator Circuit	Connector	Pins
Cab-Mounted Universal with ESC, Universal or Basic  (ABS modulators are grounded externally, i.e., common is fed to external ground)	LF IV	X2-18 pin	3
	LF OV	X2-18 pin	6
	RF IV	X2-18 pin	1
	RF OV	X2-18 pin	4
	LR IV	X2-18 pin	2
	LR OV	X2-18 pin	5
	RR IV	X2-18 pin	8
	RR OV	X2-18 pin	9
	LR (3rd Axle) IV	X3-15 pin	3
	LR (3rd Axle) OV	X3-15 pin	6
	RR (3rd Axle) IV	X3-15 pin	12
	RR (3rd Axle) OV	X3-15 pin	15
Optional with Stability Control	Trailer IV	X3-15 pin	7
	Trailer OV	X3-15 pin	10
	Trailer Common	X3-15 pin	8

Fig. 5.20





## Diagnostics, Troubleshooting and Testing

ECU	Modulator Circuit	Connector	Pins
Frame-Mounted Non-ESC	LF IV	X2-Black	2
	LF OV	X2-Black	10
	LF Common	X2-Black	11
	RF IV	X2-Black	4
	RF OV	X2-Black	3
	RF Common	X2-Black	9
	LR IV	X3-Green	12
	LR OV	X3-Green	10
	LR Common	X3-Green	11
	RR IV	X3-Green	9
	RR OV	X3-Green	7
	RR Common	X3-Green	8
	LR (3rd Axle) IV	X4-Brown	12
	LR (3rd Axle) OV	X4-Brown	10
	LR (3rd Axle) Common	X4-Brown	11
	RR (3rd Axle) IV	X4-Brown	9
	RR (3rd Axle) OV	X4-Brown	7
	RR (3rd Axle) Common	X4-Brown	8

## Diagnostics, Troubleshooting and Testing

ECU	Modulator Circuit	Connector	Pins
Frame-Mounted With ESC	LF IV	X2-Green	2
	LF OV	X2-Green	15
	LF Common	X2-Green	14
	RF IV	X2-Green	4
	RF OV	X2-Green	3
	RF Common	X2-Green	16
	LR IV	X3-Green	12
	LR OV	X3-Green	10
	LR Common	X3-Green	11
	RR IV	X3-Green	9
	RR OV	X3-Green	7
	RR Common	X3-Green	8
	LR (3rd Axle) IV	X4-Brown	12
	LR (3rd Axle) OV	X4-Brown	10
	LR (3rd Axle) Common	X4-Brown	11
	RR (3rd Axle) IV	X4-Brown	9
RR (3rd Axle) OV	X4-Brown	7	
RR (3rd Axle) Common	X4-Brown	8	

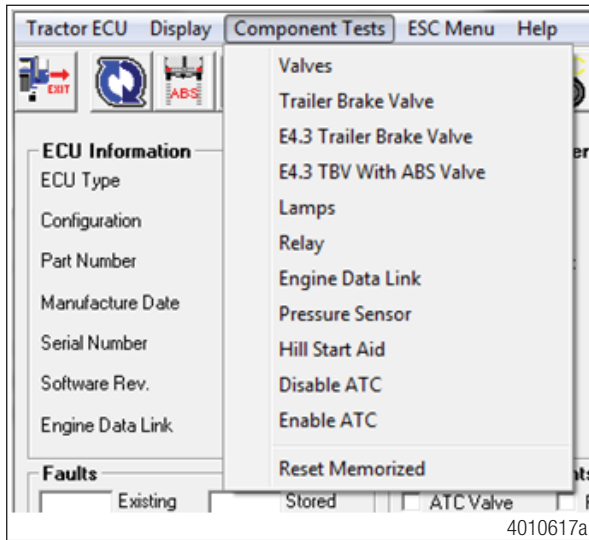
ECU	Modulator Circuit	Connector	Pins
Optional with Stability Control	Trailer IV	X2-Green	1
	Trailer OV	X2-Green	10
	Trailer Common	X2-Green	13

## 5.2.1.3 Modulator Valve Testing Available in WABCO TOOLBOX™ Software (PC Diagnostics)

The ABS modulator valves as well as the trailer modulator valve can be cycled using WABCO TOOLBOX™ Software.

To cycle the modulator valves, choose the option “Valves” from the “Component Tests” drop-down menu. Or, if you are using TOOLBOX™ Software version 11 or higher, from “Components”. Figure 5.21.

Fig. 5.21



The valve selection screen will appear where you can choose to cycle each valve individually or you can choose to cycle all valves in a pre-determined order. Figure 5.22 and Figure 5.23.

Then, listen to ensure the correct valve is cycling. This is helpful in verifying correct operation, installation and wiring.

Fig. 5.22

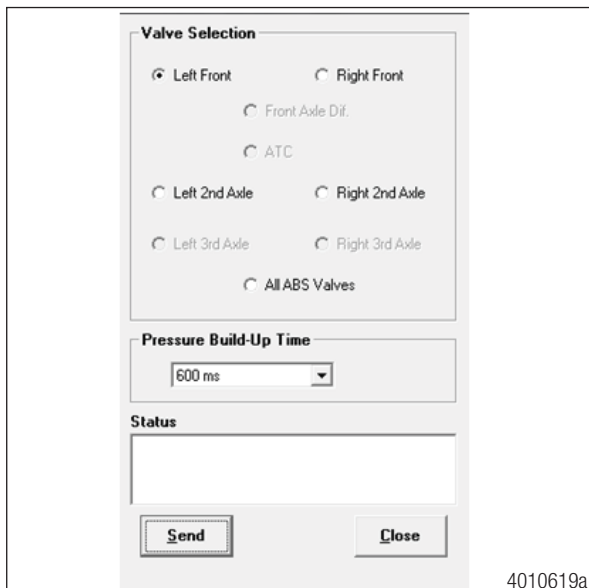
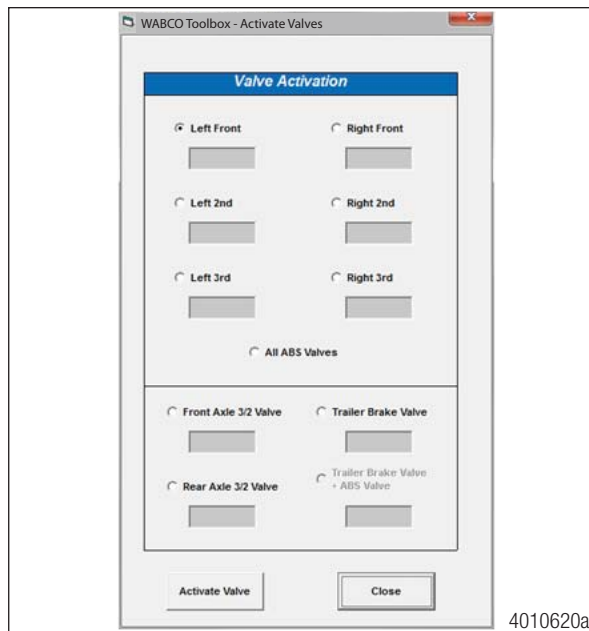


Fig. 5.23



If you are using versions older than TOOLBOX™ Software V11, to test the function of the Trailer Stability Control Modulator valve, choose “E4.3 TBV with ABS Valve” from the “Component Tests” drop-down menu. Listen to ensure the correct valve is cycling.

## 5.2.1.4 Active Braking Valves (ABV) Testing

### Electrical Checks

- Check ABV 3/2 solenoid by itself for resistance.
- Check ECU harness and ABV 3/2 solenoid together for resistance. Figure 5.24 and Figure 5.25.
- Verify no change in resistance or open circuit between ABV by itself and through harness.
- Check harness by itself for any shorts to battery and shorts to ground.

Measurements should read as follows:

Location	Measurement
ABV Supply to ABV Common	7.0-14.0 ohm for 12V system 26.3-49.0 ohm for 24V system
At ECU harness pins with ABV connected	Same as above, no more than 1 ohm difference
ECU harness by itself for battery voltage or ground	No continuity

# Diagnostics, Troubleshooting and Testing

Fig. 5.24

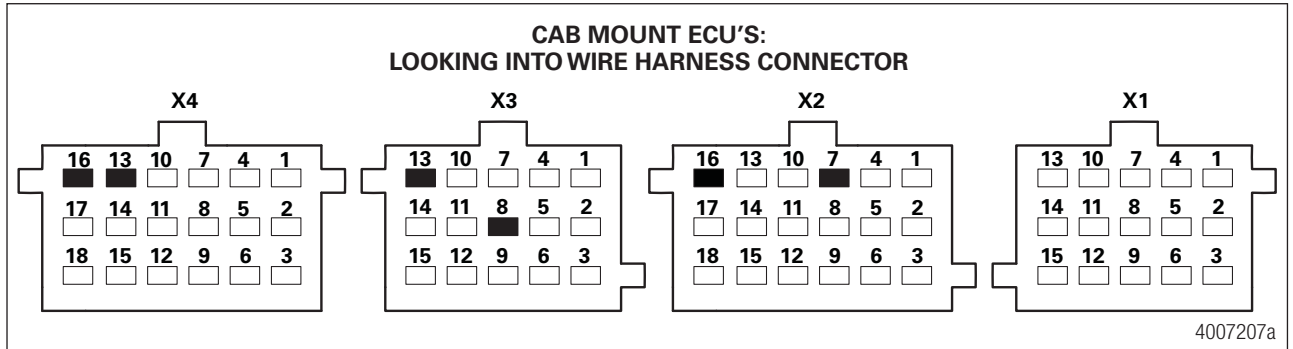
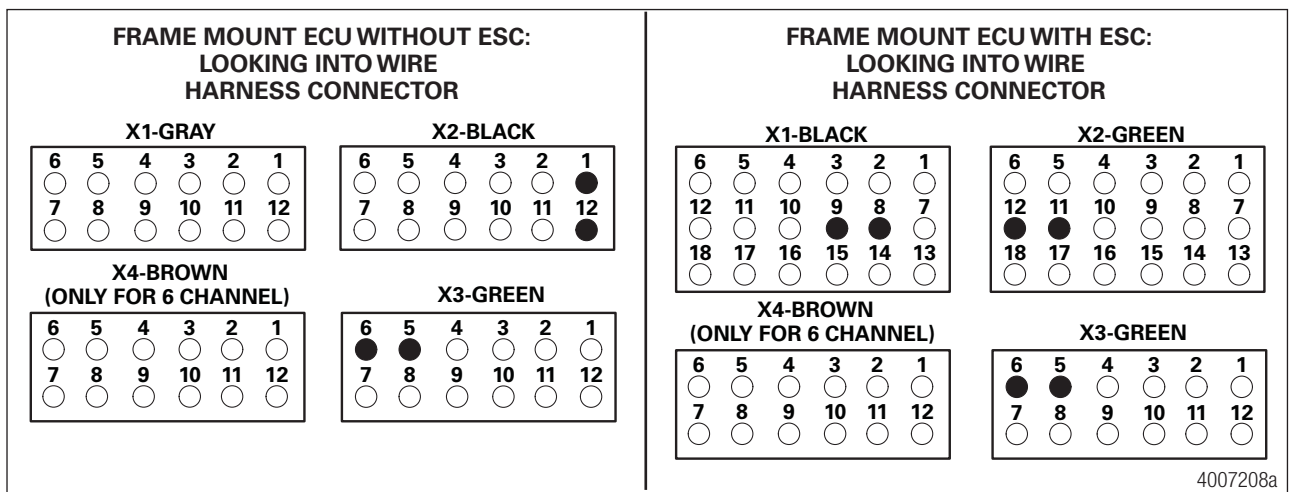


Fig. 5.25



ECU	Active Braking Valve Circuit	Connector	Pins
Cab-Mounted Universal with ESC, Universal or Basic	Drive Axle ABV Supply	X2-18 pin	16
	Drive Axle ABV Common	X2-18 pin	7
	Steer Axle ABV Supply	X4-18 pin	16
	Steer Axle ABV Common	X4-18 pin	13
	Trailer ABV Supply	X3-15 pin	13
	Trailer ABV Common	X3-15 pin	8
Frame-Mounted Non-ESC	Drive Axle ABV Supply	X3-Green	5
	Drive Axle ABV Common	X3-Green	6
	Trailer ABV Supply	X2-Black	1
	Trailer ABV Common	X2-Black	12

ECU	Active Braking Valve Circuit	Connector	Pins
Frame-Mounted with ESC	Drive Axle ABV Supply	X3-Green	5
	Drive Axle ABV Common	X3-Green	6
	Steer Axle ABV Supply	X2-Green	12
	Steer Axle ABV Common	X2-Green	11
	Trailer ABV Supply	X1-Black	9
	Trailer ABV Common	X1-Black	8

## 5.2.1.5 ABV Testing Available in WABCO TOOLBOX™ Software

The Active Braking Valves can be cycled using WABCO TOOLBOX™ Software.

To cycle the ABVs, choose the option “Valves” from the “Component Tests” drop-down menu. Figure 5.26. Or if you are using TOOLBOX™ Software version 11 or higher, from “Components”. Figure 5.27.

Fig. 5.26

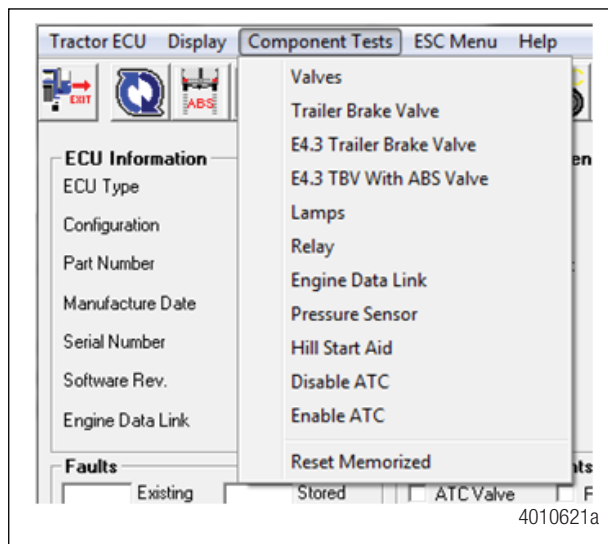
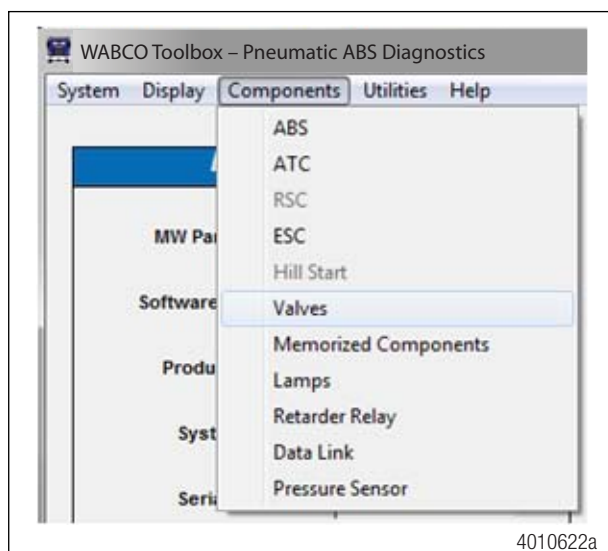


Fig. 5.27



# Diagnostics, Troubleshooting and Testing

The valve selection screen will appear where you can choose to cycle Front Axle ABV, Rear Axle ABV or Trailer ABV individually. Figure 5.28 or Figure 5.29.

Then, listen to ensure the correct valve is cycling. This is helpful in verifying correct operation, installation and wiring.

Fig. 5.28

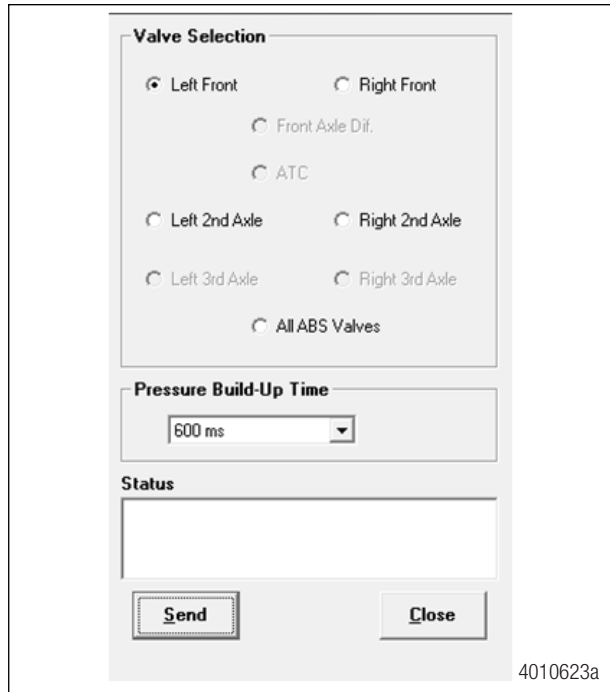


Fig. 5.29





If you are using versions older than TOOLBOX™ Software version 11, to test the function of the Trailer ABV, choose “Trailer Brake Valve” or “E4.3 Trailer Brake Valve” from the “Component Tests” drop-down menu. Listen to ensure the correct valve is cycling. If you are unsure which test option to choose, please contact the WABCO Customer Care Center at 855-228-3203 and have your ECU part number available.

## 5.2.1.6 Brake Pressure Sensor Testing

### Electrical Checks

For the following check, all of the ECU connectors must be plugged in as the ECU provides voltage and ground to the BPS.

- Take measurements at the pressure sensor harness connector. Figure 5.30.
- Measure Voltage Supply to Ground on Pin 1 of the BPS Connector Key ON.

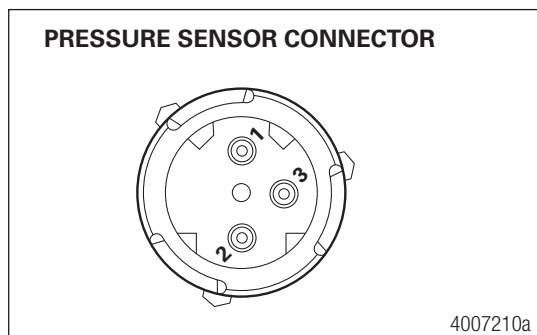
With ECU and BPS disconnected:

- Verify continuity end to end on all 3 lines.
- Verify no shorts to ground or battery on all 3 lines.
- Verify no continuity between pins.

Measurements should read as below.

Location	Measurement
Voltage Supply to Ground	8.0-16.0V
Pressure Signal or Ground Line short to battery or ground	No continuity

Fig. 5.30



Pin	Circuit
1	Voltage Supply
2	Ground
3	Pressure Signal



## 5.2.1.7 Pressure Sensor Testing Available in WABCO TOOLBOX™ Software

The pressure sensor test can be accessed through WABCO TOOLBOX™ Software under Component Tests, Pressure Sensor.

- Ensure brake pedal position and pressure is displayed in the corresponding boxes. Figure 5.31 and Figure 5.32.

Fig. 5.31

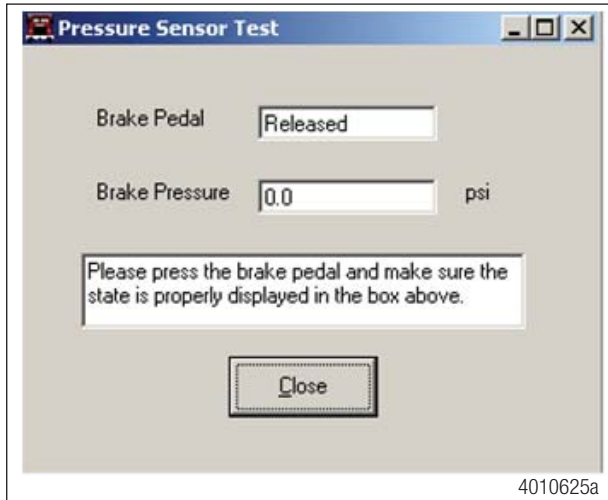
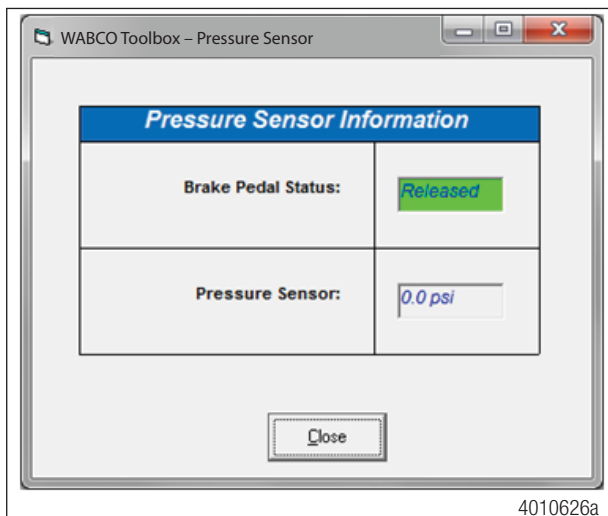


Fig. 5.32



## 5.2.1.8 ESC CAN Network Testing

The ECU, SAS and ESC module are all connected on propriety CAN network with internal terminating resistors on each one of these components. A failure to one of the components will cause others to fault out. Figure 5.33 and Figure 5.34.

Fig. 5.33

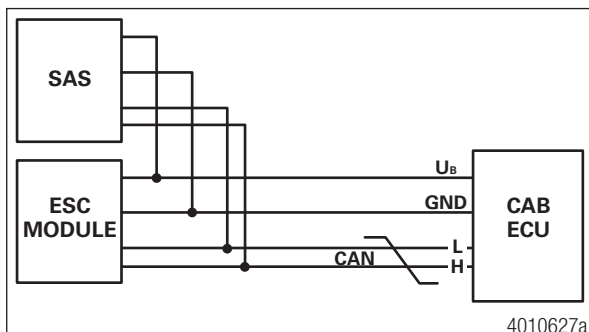
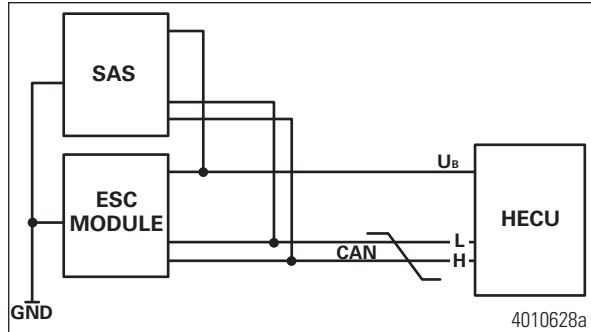


Fig. 5.34



## 5.2.1.9 ESC Module Testing

### Electrical Checks

For the following checks, all of the ECU connectors must be plugged in as well as the SAS. The ECU provides voltage, ground and CAN communication to ESC module.

- Take measurements at the ESC module harness connector. Figure 5.35 and Figure 5.36.
- Measure voltage supply Key ON.
- Measure CAN High voltage Key ON.
- Measure CAN Low voltage Key ON.
- Measure terminating resistance across CAN High and Low with Key OFF.
- Frame-mounted ECU only: Measure ground resistance Key OFF to chassis ground.

With ECU and ESC Module disconnected:

- Verify continuity end to end on each line.
- Verify no shorts to ground or battery on all lines.
- Verify no continuity between pins.

Measurements should read as follows:

Pins	Circuit	Measurement
1	Voltage Supply to Chassis Ground	8.0-16.0V
2	(Frame-mounted only) ESC Ground to Chassis Ground	Less than 1 ohm resistance
2	(Cab-mounted only) ESC Ground	Should have continuity but will not be less than 1 ohm
3 and 4	Terminating Resistance between ESC CAN-High to ESC CAN-Low	Approximately 90 ohms
1	With ECU disconnected, check power supply for battery voltage or ground.	No continuity
2	With ECU disconnected, check ground for battery voltage or ground.	No continuity
3 and 4	With ECU disconnected, check CAN lines for battery voltage or ground.	No continuity
3	CAN High Voltage to Chassis Ground	2.5-5.0V
4	CAN Low Voltage to Chassis Ground	0.1-2.4V



Do not load test across power and ground at the ESC Module.

Fig. 5.35

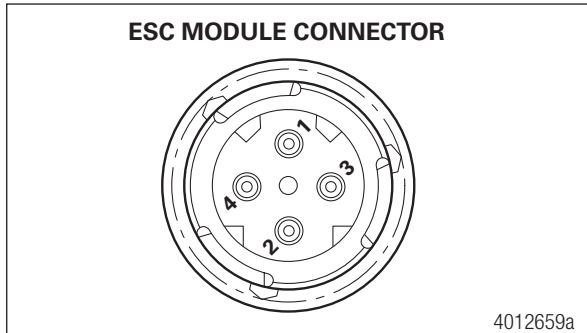
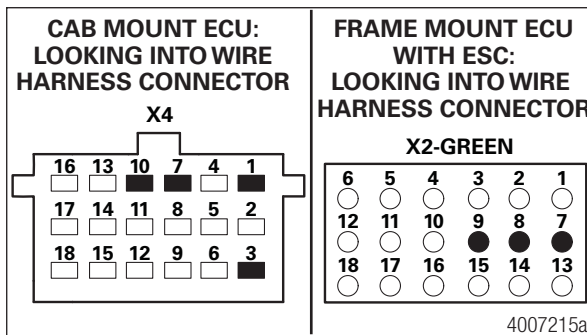


Fig. 5.36



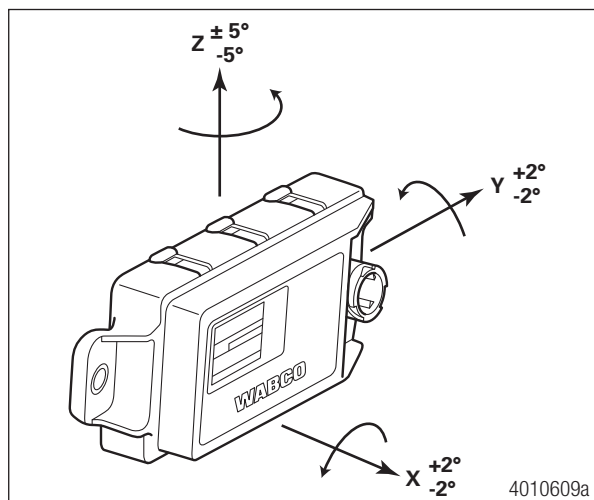
ECU	Modulator Circuit	Connector	Pins
Cab-Mounted Universal with ESC	Power Supply	X4-18 pin	7
	Ground	X4-18 pin	10
	ESC CAN-Low	X4-18 pin	1
	ESC CAN-High	X4-18 pin	3
Frame-Mounted With ESC	Power Supply	X2-Green	9
	Ground	X2-Green	External
	ESC CAN-Low	X2-Green	7
	ESC CAN-High	X2-Green	8

## 5.2.1.10 ESC Module Mounting

The ESC module contains sensors which measure both lateral acceleration and yaw rate. Thus, it is critical that the module is securely mounted, leveled and in correct location to the vehicle and that the module is mounted as expected by the ECU and as per vehicle OEM specifications.

The module should be installed in a manner where the label is right side up. The module must be mounted perpendicular to the vehicle frame rails on a cross member or cross member bracket. The module connector could be facing the front or rear of the vehicle depending on the OEM's specified mounting. It is critical that the unit be mounted in the exact location and manner as originally installed by the vehicle manufacturer. Figure 5.37.

Fig. 5.37



## 5.2.1.11 ESC Information Available in WABCO TOOLBOX™ Software 11 or Higher

ESC Information can be accessed through WABCO TOOLBOX™ Software 11 or higher under Components, ESC.

To access the ESC Information:

- If you are using TOOLBOX™ Software version 11 or higher, click on the “Components” button. A drop-box will appear. Select “ESC” then select “ESC Info”. Figure 5.38 and Figure 5.39.

Fig. 5.38

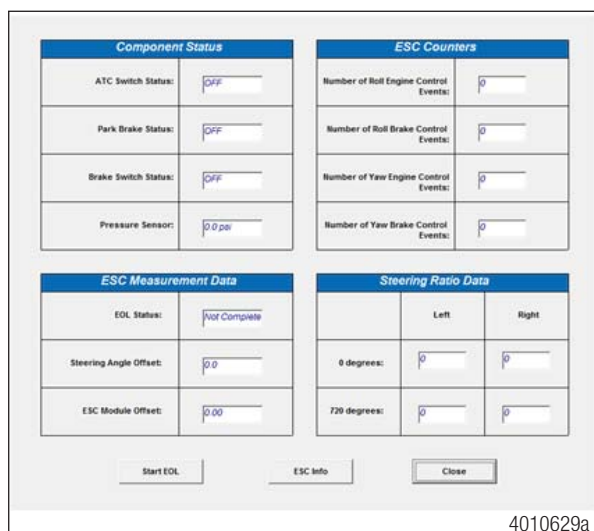
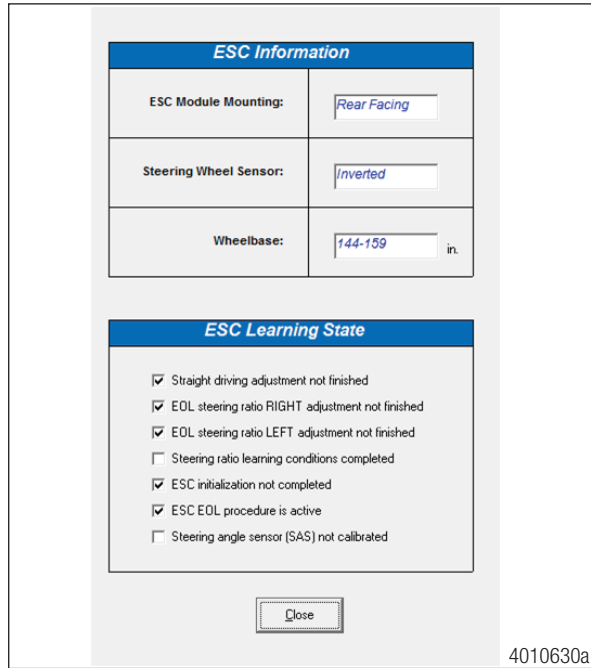


Fig. 5.39



4010630a

## 5.2.1.12 Steering Angle Sensor (SAS) Testing

### Electrical Checks

The following tests are for WABCO SAS Only.

- Disconnect SAS and check terminating resistance across Pin 1 and Pin 2 of the SAS. Figure 5.40 and Figure 5.41.

For the following checks, all the ECU and ESC module connectors must be plugged in as the ECU provides all voltage, ground and CAN communications. Figure 5.43 and Figure 5.44.

- Take measurements at the SAS harness connector side. Figure 5.42.
  - Check Key On CAN Low voltage on Pin 1.
  - Check Key On CAN High voltage on Pin 4.
  - Check Key On Voltage Supply on Pin 5.
  - Check Key Off resistance across CAN low Pin 1 and CAN High Pin 4.

Location	Measurement
WABCO SAS terminating resistor on sensor	Approximately 180 ohms
CAN High Voltage	2.5-5.0V
CAN Low Voltage	0.1-2.4V
Voltage Supply to Ground	8.0-16.0V
ESC CAN-High to ESC CAN-Low	Approximately 90 ohm
SAS harness jumper (Pin 2 to Pin 4 or Pin 2 to Pin 3)	Continuity
ESC CAN-High or CAN-Low to Power or Ground (with ECU, ESC Module and SAS unplugged)	No continuity



For correct sensor operation, there must be a jumper wire on the harness side across either Pin 2 to Pin 3 or Pin 4 so terminating resistor is connected as shown in Figure 5.41.

Fig. 5.40

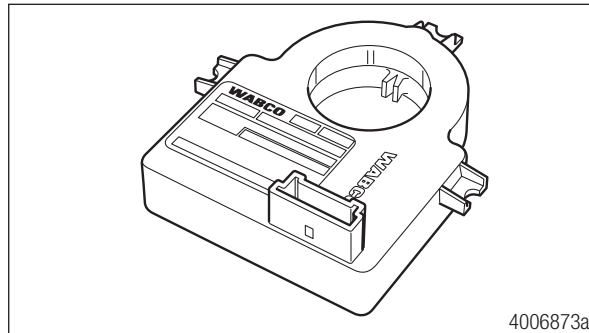


Fig. 5.41

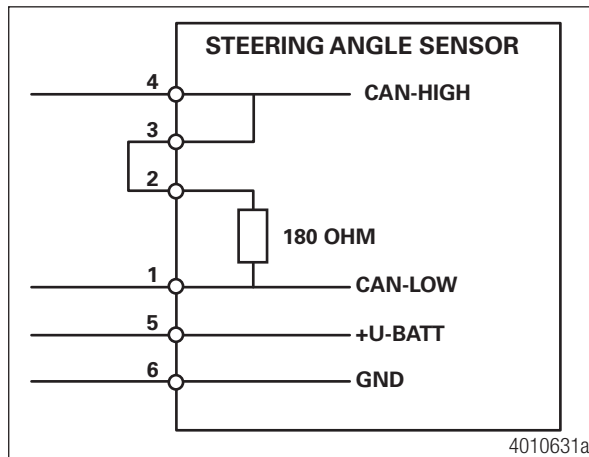
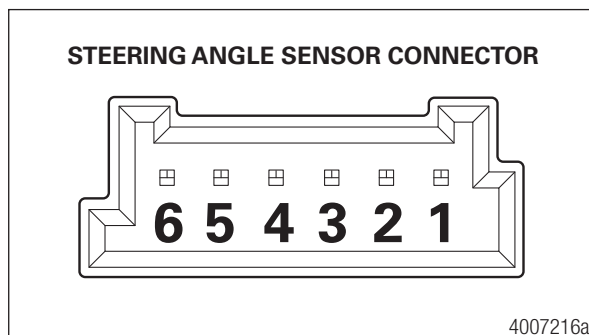


Fig. 5.42

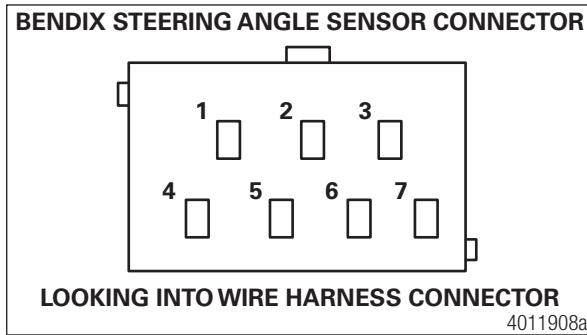


Pin	Circuit
1	CAN-Low
2	Terminating Resistor
3	CAN-High
4	CAN-High
5	Power
6	Ground



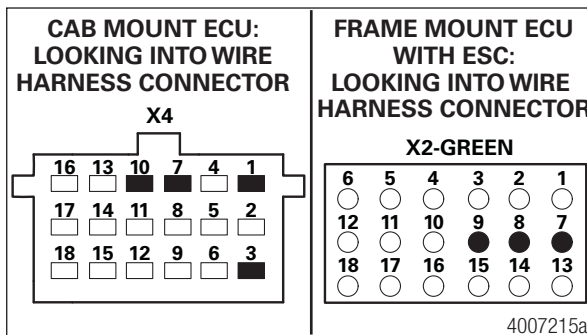
Do not load test across power and ground at the SAS.

Fig. 5.43



Pin	Circuit
1	Ground
2	Power
3	CAN-High
4	CAN-Low

Fig. 5.44



## 5.2.1.13 ECU Circuit Testing

### Electrical Checks

- Verify vehicle batteries, charging system and fuses are in good working condition.
- Load test battery and ignition circuits to ground at the ECU harness using a 2-4 amp sealed lamp and verify lamp does not flicker and it is on steady.
- Take measurements at the ECU harness pins. Figure 5.45 and Figure 5.46.

Measurements should read as follows:

Location	Measurement
Supply Voltage, Battery to chassis Ground	9.0-16.0V for 12V system 18.0-32.0V for 24V system
Supply Voltage, Ignition to chassis Ground	9.0-16.0V for 12V system 18.0-32.0V for 24V system
ECU ground to chassis ground	Less than 1 ohm resistance
Main ground to chassis ground	Less than 1 ohm resistance

Fig. 5.45

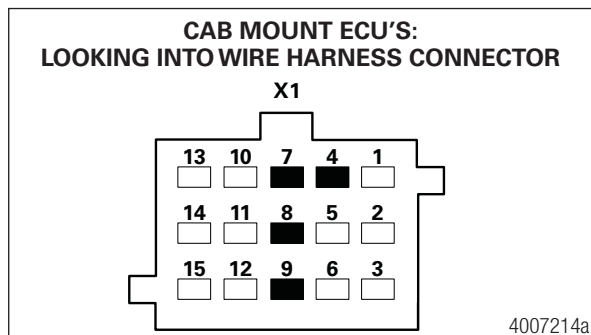
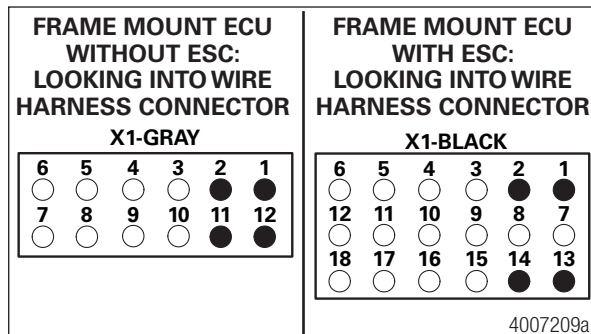


Fig. 5.46





ECU	Modulator Circuit	Connector	Pins
Cab-Mounted Universal with ESC, Universal or Basic	Supply Voltage, Battery	X1-15 pin	8
	Supply Voltage, Ignition	X1-15 pin	7
	Central Ground	X1-15 pin	4, 9
Frame-Mounted Non-ESC	Supply Voltage, Battery (Could be IGN)	X1-Gray	1
	Supply Voltage, Ignition	X1-Gray	2
	Central Ground	X1-Gray	11, 12
Frame-Mounted With ESC	Supply Voltage, Battery	X1-Black	1
	Supply Voltage, Ignition	X1-Black	2
	Central Ground	X1-Black	13, 14

## 5.2.1.14 J1939 Serial Communications Testing

### Electrical Checks

- If the ABS ECU is the only ECU on the J1939 datalink which cannot communicate, then take measurements at the ABS ECU connector. If other ECUs are not communicating, then troubleshoot the vehicle datalink backbone and contact the vehicle OEM for technical assistance if required.
- Check for devices that could be overloading the J1939 datalink slowing down communications.
- Verify J1939 High and Low have correct voltage readings, Key ON, while datalink communications are active.
- For resistance measurements, the vehicle battery must be disconnected and the ignition must be OFF. Figure 5.47, Figure 5.48, Figure 5.49 and Figure 5.50.

Measurements should read as follows:

Location	Measurement
Across J1939 High and Low	Approximately 60 ohms
J1939 Low voltage	0.1V-2.4V
J1939 High voltage	2.5V-5.0V
J1939 High or J1939 Low to Ground or Power Supply	No continuity

Fig. 5.47

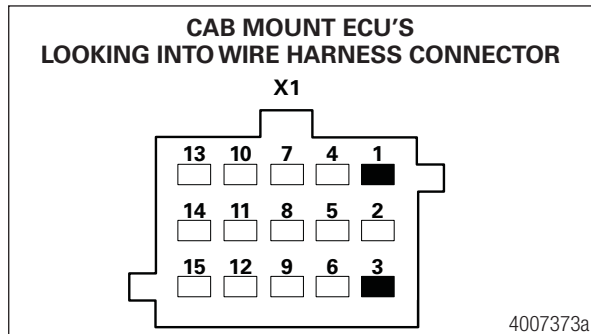
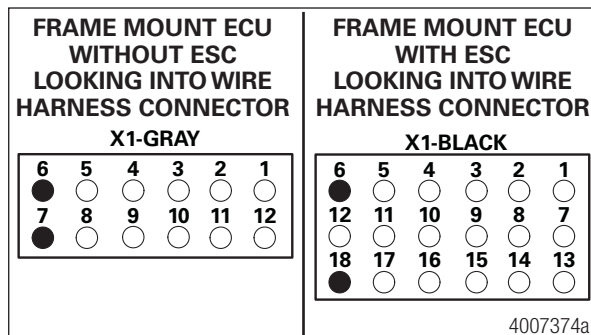


Fig. 5.48



ECU	J1939 Datalink Circuit	Connector	Pins
Cab-Mounted All	J1939 High	X1-15 pin	3
	J1939 Low	X1-15 pin	1
Frame-Mounted Without ESC	J1939 High	X1-Gray	7
	J1939 Low	X1-Gray	6
Frame-Mounted With ESC	J1939 High	X1-Black	18
	J1939 Low	X1-Black	6

ECU	J1587 Datalink Circuit	Connector	Pins
Cab-Mounted ECU	J1939 High	X1	11
	J1939 Low	X1	10
Frame-Mounted ECU without ESC	J1939 High	X1-Gray	4
	J1939 Low	X1-Gray	9
Frame-Mounted ECU with ESC	J1939 High	X1-Black	4
	J1939 Low	X1-Black	16

Fig. 5.49

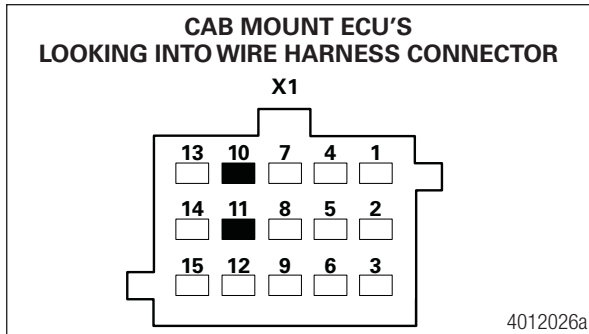
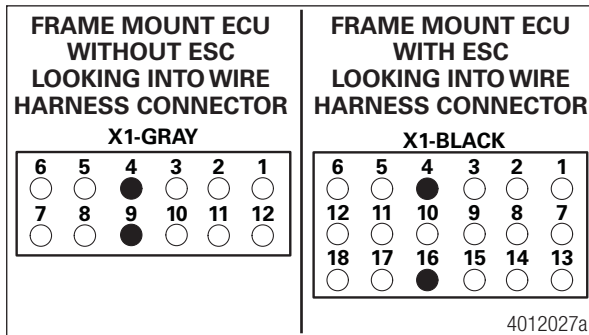


Fig. 5.50



## 6 Component Replacement

### ⚠ WARNING

To prevent serious eye injury, always wear safe eye protection when you perform vehicle maintenance or service.

### ⚠ WARNING

Release all air from the air systems before you remove any components. Pressurized air can cause serious personal injury.

### ⚠ CAUTION

When welding on an ABS- or ABS/ATC-equipped vehicle is necessary, disconnect the power connector from the ECU to prevent damage to the electrical system and ABS/ATC components.

## 6.1 Component Removal and Installation

### 6.1.1 Wheel Speed Sensors

#### 6.1.1.1 Sensor Lubricant Specification

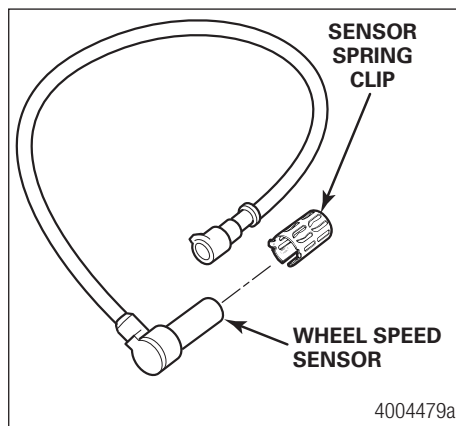
WABCO specifications call for a sensor lubricant with the following characteristics:

Lubricant must be mineral oil-based and contain molydisulfide. It should have excellent anti-corrosion and adhesion characteristics, and be capable of continuous function in a temperature range of  $-40^{\circ}$  to  $300^{\circ}$ F ( $-40^{\circ}$  to  $150^{\circ}$ C).

Lubricants approved for use on WABCO sensors and spring clips are as follows. Figure 6.1.

- Mobilith SHC-220 (Mobil)
- TEK 662 (Roy Dean Products)
- Staburags NBU 30 PTM (Kluber Lubrication)
- Valvoline EP 633

Fig. 6.1



# Component Replacement

## Removal



When replacing the wheel speed sensor, the sensor spring clip must also be replaced.

## WARNING

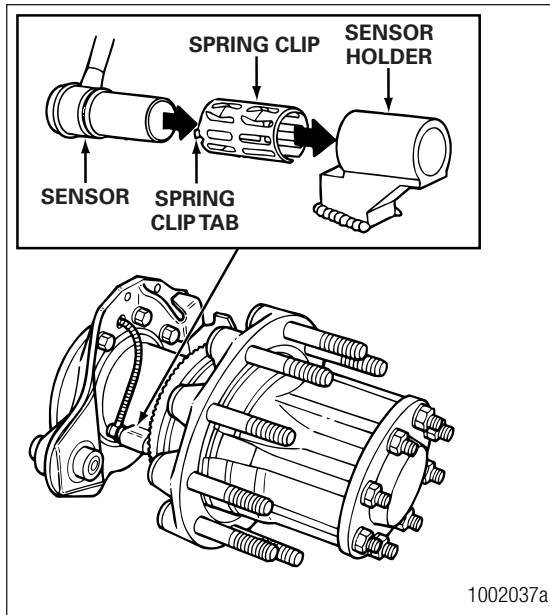
Park the vehicle on a level surface. Block the wheels to prevent the vehicle from moving. Support the vehicle with safety stands. Do not work under a vehicle supported only by jacks. Jacks can slip and fall over. Serious personal injury and damage to components can result.

1. Place blocks under the tires to stop the vehicle from moving. Apply the parking brake.
2. If necessary, raise the tires off the ground. Place safety stands under the axle.
3. Depending on the axle, wheel hub and brake configurations, some components might have to be removed to obtain access to wheel speed sensor. Follow the vehicle OEMs guidelines to gain access to wheel speed sensor.
4. Disconnect the fasteners that hold the sensor cable to other components.
5. Disconnect the sensor cable from the chassis harness.
6. Remove the sensor from the sensor holder. Use a twisting motion if necessary. **Do not pull on the cable.** Figure 6.2 and Figure 6.3.

Fig. 6.2



Fig. 6.3



7. Remove the sensor spring clip.

## Installation

1. Connect the sensor cable to the chassis harness.
2. Install the fasteners used to hold the sensor cable in place.
3. Apply a WABCO recommended lubricant to the sensor spring clip and sensor.
4. Install the sensor spring clip. Make sure the spring clip tabs are on the inboard side of the vehicle.
5. Push the sensor spring clip into the bushing in the steering knuckle until the clip stops.
6. Push the sensor completely into the sensor spring clip until it contacts the tooth wheel.



After installation, there should be no gap between the sensor and the tooth wheel. During normal operation, a gap of up to 0.04-inch (1.016 mm) is allowable.

7. Remove the blocks and safety stands.

## 6.1.1.2 Modulator Valves

### Removal

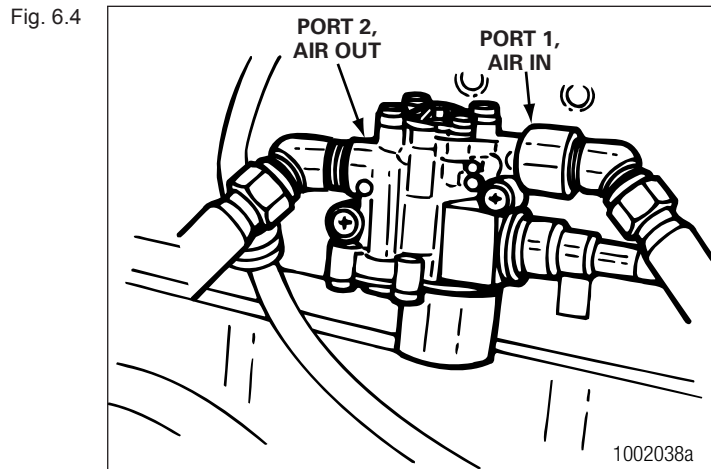
#### WARNING

Park the vehicle on a level surface. Block the wheels to prevent the vehicle from moving. Support the vehicle with safety stands. Do not work under a vehicle supported only by jacks. Jacks can slip and fall over. Serious personal injury and damage to components can result.

1. Turn the ignition switch to the OFF position. Apply the parking brake.
2. Place blocks under the front and rear tires to stop the vehicle from moving.

# Component Replacement

3. If necessary, raise the vehicle off the ground and place safety stands under the axle.
4. Disconnect the wiring connector from the ABS valve.
5. Disconnect the air lines from Ports 1 (air supply) and 2 (air discharge) of the ABS valve. Figure 6.4.



6. Remove the two mounting capscrews and nuts.
7. Remove the ABS valve.

## Installation

### **⚠ CAUTION**

Moisture can affect the performance of all ABS/ATC systems, as well as the standard braking system. Moisture in air lines can cause air lines to freeze in cold weather.

1. Install the ABS valve with two mounting capscrews and nuts. Tighten the capscrews per the manufacturer's recommendation.
2. Connect the line to the brake chambers to Port 2 of the ABS valve. Connect the air supply line to Port 1 of the ABS valve.
3. Connect the wiring connector to the ABS valve. Hand tighten only.
4. Remove the blocks and stands.
5. Test the installation.

## Checking the Installation

1. Apply the brakes. Listen for leaks at the modulator valve.
2. Turn the ignition on and listen to the modulator valve cycle. If the valve fails to cycle, check the electrical cable connection. Make repairs as needed.
3. After any repair has been performed, cycle the ignition key and test drive the vehicle. Verify that the ABS indicator lamp operates correctly.

### 6.1.1.3 Active Braking Valves (ABV)

#### Removal

Depending on the OEM specs and vehicle system configuration, ABVs may be located near the rear axle, front axle and in line with trailer service/control line. Consult the vehicle OEM for exact location of these valves.

## **⚠ WARNING**

Park the vehicle on a level surface. Block the wheels to prevent the vehicle from moving. Support the vehicle with safety stands. Do not work under a vehicle supported only by jacks. Jacks can slip and fall over. Serious personal injury and damage to components can result.

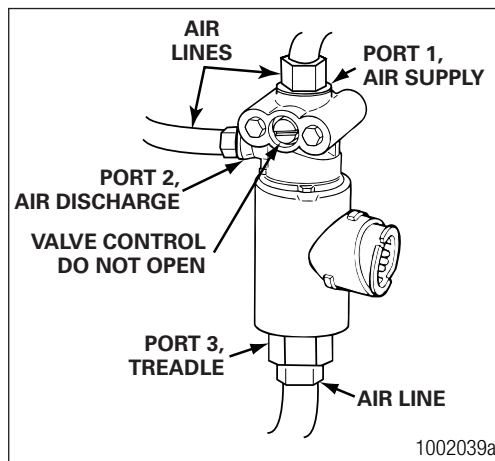
1. Turn the ignition switch to the OFF position. Apply the parking brake.
2. Place blocks under the front and rear tires to stop the vehicle from moving.
3. If necessary, raise the vehicle off the ground. Place safety stands under the axle.

## **⚠ WARNING**

Relieve line pressure by bleeding the air from the appropriate supply tank. Pressurized air can cause serious personal injury.

4. Disconnect the wiring from the valve.
5. Disconnect the air lines from Port 1 (air supply), Port 2 (air discharge) and Port 3 (treadle) of the ATC valve. Figure 6.5.

Fig. 6.5



6. Remove the two mounting capscrews and nuts. Remove the valve.

### **Installation**

1. Install the valve with two mounting capscrews and nuts. Tighten the capscrews per the manufacturer's recommendation.
2. Connect the air supply, discharge and treadle lines to Ports 1, 2 and 3 of the valve.
3. Connect the harness connector to the valve. Hand tighten only.
4. Remove the blocks and stands.
5. Test the installation.

### **6.1.1.4 Checking the ABV Installation**

To test the active braking valve:

1. Turn the ignition to the ON position and verify that the ATC/ Stability Control lamp operates correctly.



# Component Replacement

2. Start the vehicle.
3. Fully charge the reservoirs with air. Shut off the vehicle.
4. Apply the brakes.
5. Listen for air leaks at the valve.
6. Release the brakes.
7. Activate the valve using TOOLBOX™ Software. Verify correct operation and that there are no active codes.
8. Make necessary repairs if needed.
9. Drive the vehicle. Verify that the ATC indicator lamp operates correctly.

## 6.1.1.5 Checking the Trailer ABV Installation

1. Connect the blue glad hand to a 50 cu. in. (819 cu. cm) air tank.
2. Start the vehicle.
3. Fully charge the reservoirs with air. Shut off the vehicle.
4. Activate the valve using TOOLBOX™ Software; verify correct operation and no active codes.
5. Listen for air leaks at the valve.
6. Make necessary repairs if needed.
7. Turn the ignition ON. Verify that the ATC/Stability Control indicator lamp operates correctly.

## 6.1.1.6 ABS Valve Packages

### Removal and Installation — Complete Package

#### **WARNING**

Park the vehicle on a level surface. Block the wheels to prevent the vehicle from moving. Support the vehicle with safety stands. Do not work under a vehicle supported only by jacks. Jacks can slip and fall over. Serious personal injury and damage to components can result.

#### **WARNING**

Relieve line pressure by bleeding the air from the appropriate supply tank. Pressurized air can cause serious personal injury.

1. Place blocks under tires to stop the vehicle from moving.
2. If necessary, raise the tires off the ground.
3. Drain the air from all system air tanks.

# Component Replacement

4. Remove all the air lines and connections from the ABS valve package. Figure 6.6 and Figure 6.7.

Fig. 6.6

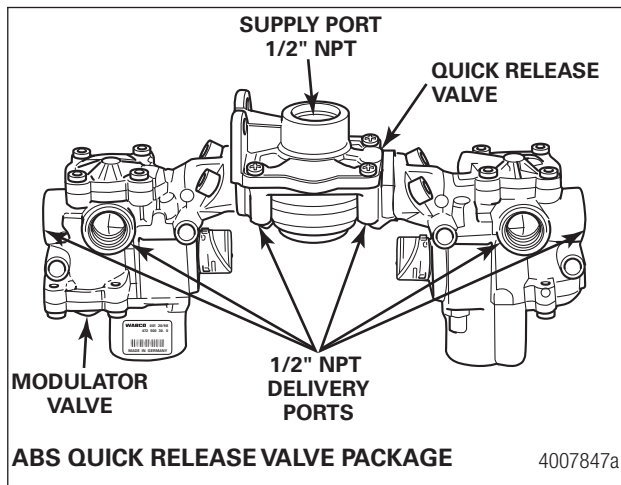
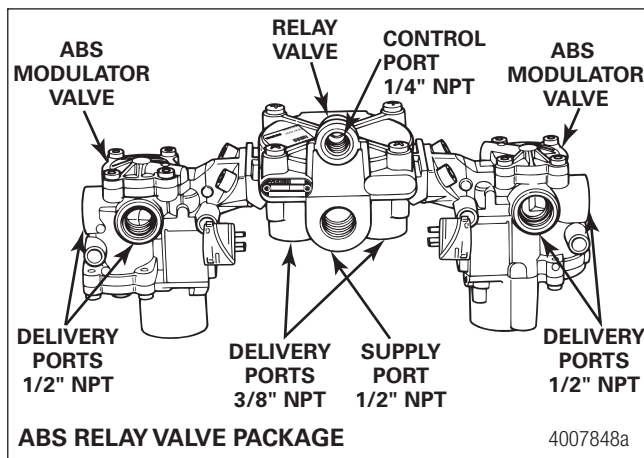


Fig. 6.7



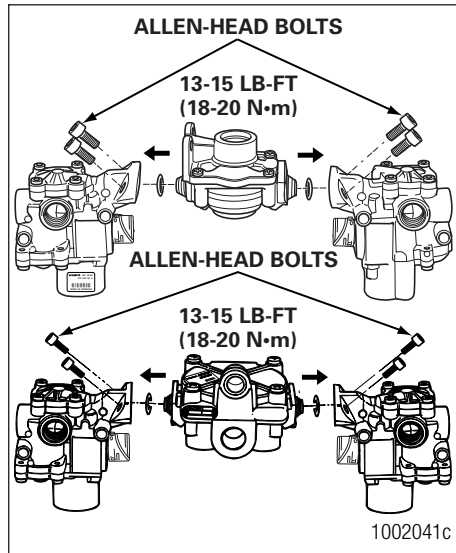
5. Remove the mounting bolts from the valve package. Remove the valve package from the vehicle.
6. **Replace the ABS valve package:** Tighten the bolts to the vehicle manufacturer's recommendation. Remove the blocks and safety stands as necessary.
7. Test the installation.

# Component Replacement

## Removal and Installation — Component Valves

1. Remove the ABS valve package from the vehicle. Figure 6.8.

Fig. 6.8



2. Use a 6 mm Allen wrench to loosen and remove the Allen-head bolts.
3. Carefully separate the ABS modulator valve(s) from the relay or quick release valve.
4. Remove and discard old O-rings. Lubricate replacement O-rings with the grease provided.
5. Plug any unused ports on the replacement valve(s).
6. Attach the ABS modulator valve(s) to the relay or quick release valve. Use a 6 mm Allen wrench to tighten the Allen-head bolts to 13-15 lb-ft (18-20 Nm).
7. **Replace the ABS valve package:** Tighten the bolts to the vehicle manufacturer's recommendation. Remove the blocks and safety stands as necessary.
8. Check the valves for leaks:
  - Modulator valve(s). Refer to the procedure for checking the modulator valve installation in this section.
  - Relay or quick release valve. Refer to the procedure for checking the quick release or relay valve installation in this section.

### 6.1.1.7 Active Braking Valve on the ABS Valve Package

#### Removal



If there is enough room to work, it is not necessary to remove the valve package from the vehicle before replacing the active braking valve (solenoid valve). If the valve package must be removed, follow the instructions for removing and replacing the ABS Valve Package that appear in this section of the manual.

#### WARNING

Relieve line pressure by bleeding the air from the appropriate supply tank. Pressurized air can cause serious personal injury.

# Component Replacement

When installing the new active braking valve (solenoid valve) on the valve package, you must use the new O-rings, seals, mounting bolts and lubricant included with the replacement kit.

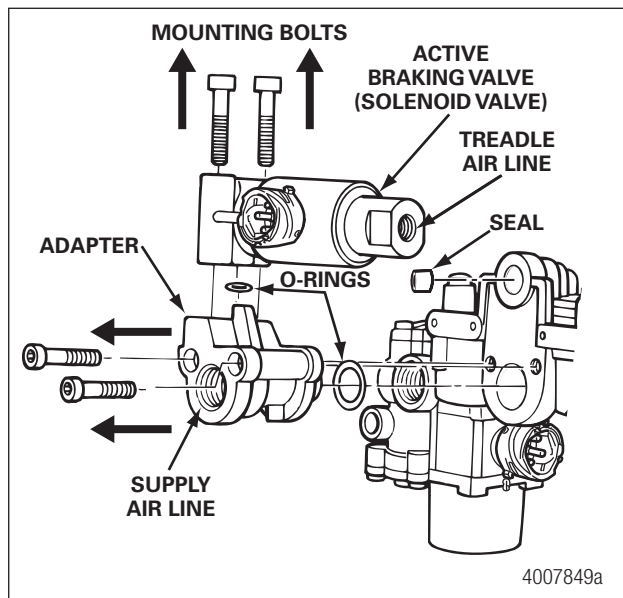
1. Turn the ignition switch to the OFF position. Apply the parking brake.
2. Place blocks under the front and rear tires to stop the vehicle from moving.
3. If necessary, raise the vehicle off the ground. Place safety stands under the axle.

## **⚠ WARNING**

Relieve line pressure by bleeding the air from the appropriate supply tank. Pressurized air can cause serious personal injury.

4. Disconnect the wiring from the solenoid valve.
5. Disconnect the supply air line from the adapter and the treadle air line from the solenoid valve.
6. Use a 5 mm Allen wrench to remove the two screws that hold the adapter piece to the relay valve portion of the valve package.
7. Use a 6 mm Allen wrench to remove the two mounting bolts that hold the solenoid valve to the adapter piece. Remove the solenoid valve from the adapter piece. Remove the solenoid valve.
8. Remove the adapter piece, seal and O-rings from the valve package. Figure 6.9.

Fig. 6.9

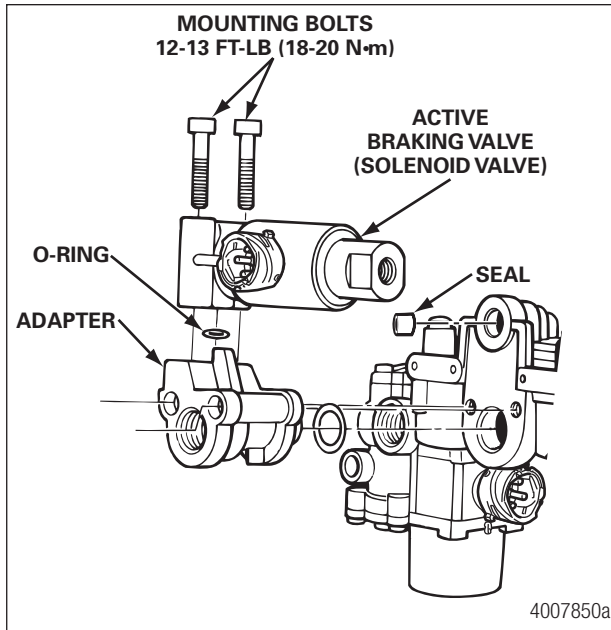


## **Installation**

1. Clean and lubricate the small adapter piece O-ring. Install the O-ring on the adapter piece.
2. Use the two new M8 Allen-head bolts to attach the solenoid valve to the adapter piece. Use a 6 mm Allen-head tool to tighten to 13-15 lb-ft (18-20 Nm). Figure 6.10.

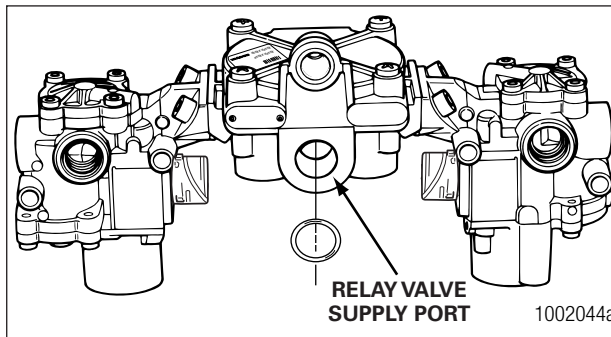
# Component Replacement

Fig. 6.10



3. Lubricate the replacement seal and install it in Port 2 of the solenoid valve.
4. Lubricate the large replacement O-ring and install it in the groove of the relay valve supply port. Figure 6.11.

Fig. 6.11

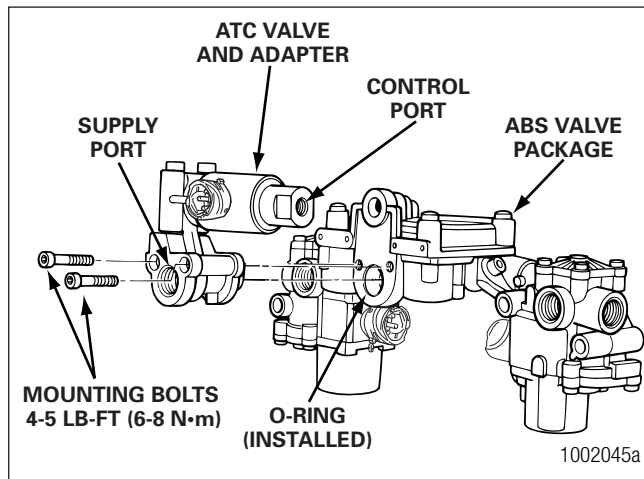


Use WABCO-recommended lubricant.

# Component Replacement

5. Use the two M6 Allen-head bolts to attach the adapter to the relay valve. Use a 5 mm Allen-head tool to tighten to 4-5 lb-ft (6-8 Nm). Figure 6.12.

Fig. 6.12



6. Connect the supply air line to the supply port on the adapter.
7. Connect the treadle air line to the control port on the solenoid valve. Place a wrench on the adapter to prevent the control port from twisting. Tighten the fitting to 15 ft-lb (20 Nm). Do not over tighten.
8. Attach the wiring connector to the solenoid valve. Hand tighten only.
9. Remove the blocks and stands.
10. Test the installation.

## Checking the Installation

1. Start the vehicle.
2. Fully charge the reservoirs with air. Shut off the vehicle.
3. Apply the brakes.
4. Listen for air leaks at all valves.
5. Drive the vehicle. Verify that the ABS indicator lamp operates correctly.

## 6.1.1.8 Electronic Control Unit (ECU)

### Removal

#### WARNING

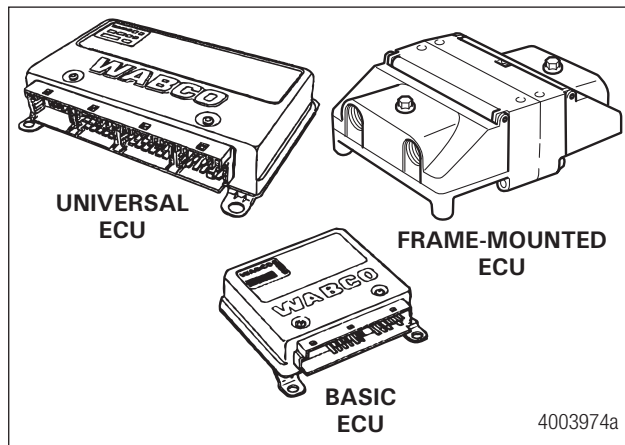
Park the vehicle on a level surface. Block the wheels to prevent the vehicle from moving. Support the vehicle with safety stands. Do not work under a vehicle supported only by jacks. Jacks can slip or fall over. Serious personal injury and damage to components can result.

1. Turn the ignition switch to the OFF position. Apply the parking brake.
2. Place blocks under the front and rear tires to prevent the vehicle from moving.
3. Disconnect the wiring harness connectors from the ECU.

# Component Replacement

4. Remove the mounting hardware. Remove the ECU. Figure 6.13.

Fig. 6.13



## Installation

1. Install the ECU using the manufacturer's mounting hardware. Tighten the hardware per the manufacturer's recommendation.
2. Install the wiring harness connectors to the ECU.
3. Remove the blocks.
4. Test the installation.



If ECU has roll stability control (RSC), mounting of the ECU is crucial for proper operation due to internal accelerometer. Note the location installation of the ECU before removal. After installing ECU, verify the ECU is properly leveled and securely mounted on the right location as per OEM specs. See Section 4 RSC components for further information.

## Testing the Installation

To test the ECU installation:

1. Turn the ignition ON and verify that the ABS self test and ABS light comes on and goes off.
  - Wheel speed related faults require a vehicle speed over 4 mph before the ABS light turns off and the code clears.
2. Use TOOLBOX™ Software to verify system has no active faults.
  - ECUs with Electronic Stability Control (ESC) will require system to be calibrated whenever a component has been replaced.
  - Follow the ESC End of Line Calibration Procedure described in this manual.
  - When the ESC End of Line Calibration Procedure is completed, the ABS and ATC/ESC lamps should come on and go back off when ignition power is turned on. The ATC/ESC lamp may remain on briefly after the ABS lamp goes off.
3. There should not be any active faults displayed in the ECU memory.

# Component Replacement

## 6.1.1.9 Steering Angle Sensor (SAS) — WABCO Only

### Removal

#### **⚠ WARNING**

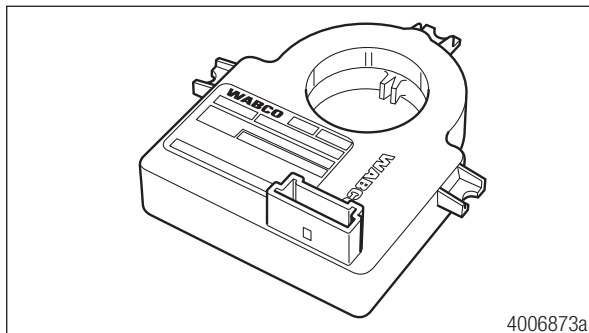
Park the vehicle on a level surface. Block the wheels to prevent the vehicle from moving. Support the vehicle with safety stands. Do not work under a vehicle supported only by jacks. Jacks can slip or fall over. Serious personal injury and damage to components can result.

#### **⚠ WARNING**

If equipped, disable the supplemental restraint system (air bag) to avoid serious personal injury. Refer to the vehicle manufacturer's service publication for further information.

1. Center the steering wheel with the front wheels positioned straight ahead.
2. Turn the ignition switch to the OFF position. Apply the parking brake.
3. Place blocks under the front and rear tires to prevent the vehicle from moving.
4. Locate the SAS on the steering column shaft, either near the universal joint on the bottom of the column or under the steering wheel near the top of the column.
5. If the SAS is located at the top of the steering column, remove the vehicle steering wheel using the recommended steering wheel puller.
6. The SAS is attached by three screws to the steering column with the center tab located in the grooved steering column shaft. Figure 6.14.

Fig. 6.14



7. Disconnect the wiring harness connector from the SAS. (Note the position of the connector either facing up or down.)
8. Remove the attaching screws and slide the SAS off of the steering column shaft.

### Installation

#### **⚠ CAUTION**

If the SAS is not installed in the correct orientation, it will not function correctly and may become damaged.

1. Apply a small amount of the supplied grease to the tab in the center of the SAS and to the machined groove on the steering shaft.



# Component Replacement

2. Install the SAS with the connector facing the same direction as the original. Place the SAS over the steering column shaft and slide it into place with the SAS tab placed in the groove that is machined on the steering column shaft.
3. Using the new furnished screws, replace the attaching screws and tighten to a maximum of 22 in-lb (2.5 Nm).
4. Install the SAS wiring harness connector by pushing the connector together until the small tab snaps into place.
5. Install the steering wheel and tighten per the manufacturer's recommendation.
6. Remove the blocks.
7. Test the installation.

## Test the Installation

To test the SAS installation, the system must be calibrated.

1. Follow the ESC End of Line Calibration Procedure described in this manual.
2. When the ESC End of Line Calibration Procedure is completed, the ABS and ATC/ESC lamps should come on and go back off when ignition power is turned on. The ATC/ESC lamp may remain on briefly after the ABS lamp goes off.
3. There should not be any active faults displayed in the ECU memory.

## 6.1.1.10 Electronic Stability Control (ESC) Module

### Removal

#### **WARNING**

Park the vehicle on a level surface. Block the wheels to prevent the vehicle from moving. Support the vehicle with safety stands. Do not work under a vehicle supported only by jacks. Jacks can slip and fall over. Serious personal injury and damage to components can result.

1. Turn the ignition switch to the OFF position. Apply the parking brake.
2. Place blocks under the front and rear tires to prevent the vehicle from moving.
3. If necessary, raise the vehicle off the ground and place safety stands under the vehicle.
4. Disconnect the wiring harness connector from the ESC module. Figure 6.15 and Figure 6.16.

Fig. 6.15

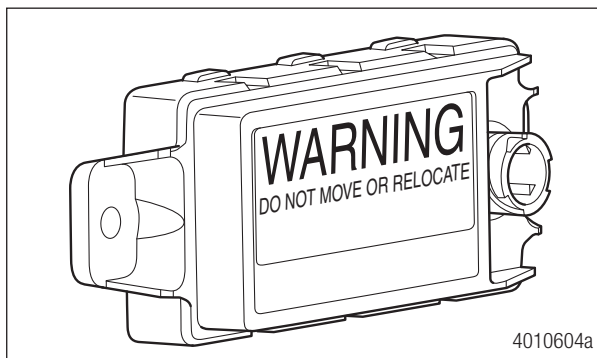
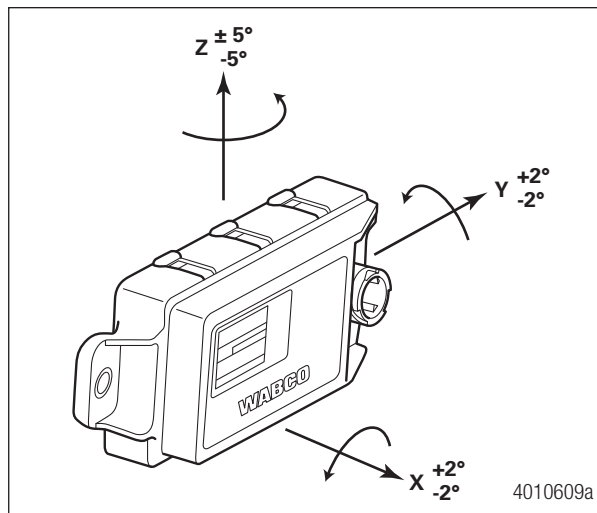


Fig. 6.16



5. Remove the two mounting capscrews and nuts. Remove the ESC module.



ESC modules are installed by the OEM close to the vehicle center of gravity. Depending on the vehicle manufacturer, the ESC module might face towards the front of the vehicle or rear. For correct operation and the best performance, verify the ESC module is correctly leveled and securely mounted as per OEM specs. Do not move the module to a different location as this will affect the system performance.

## Installation



It is important that the module is aligned correctly and the tab on the ESC mounting surface fits into the appropriate hole.

1. Install the ESC module with the two capscrews and nuts. Tighten the capscrews per the manufacturer's recommendation.
2. Connect the wiring harness connector to the ESC module. Hand tighten only.
3. Remove the stands and blocks.
4. Test the installation.

## Test the Installation

To test the ESC module installation, the system must be calibrated.

1. Follow the ESC End of Line Calibration Procedure described in this manual.
2. When the ESC End of Line Calibration Procedure is completed, the ABS and ATC/ESC lamps should come on and go back off when ignition power is turned on. The ATC/ESC lamp may remain on briefly after the ABS lamp goes off.
3. There should not be any active faults displayed in the ECU memory.

# Component Replacement

## 6.1.1.11 Brake Pressure Sensor

### Removal

#### **WARNING**

Park the vehicle on a level surface. Block the wheels to prevent the vehicle from moving. Support the vehicle with safety stands. Do not work under a vehicle supported only by jacks. Jacks can slip and fall over. Serious personal injury and damage to components can result.

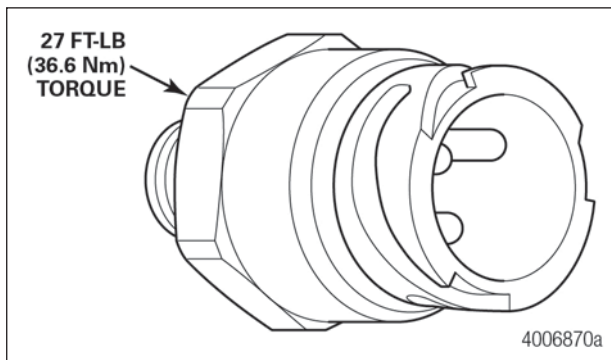
1. Turn the ignition switch to the OFF position. Apply the parking brake.
2. Place blocks under the front and rear tires to prevent the vehicle from moving.
3. If necessary, raise the vehicle off the ground and place safety stands under the vehicle.

#### **WARNING**

Relieve line pressure by bleeding the air from the appropriate supply tank. Pressurized air can cause serious personal injury.

4. Disconnect the wiring harness connector from the brake pressure sensor. Figure 6.17.

Fig. 6.17



5. Disconnect the air line or unscrew the brake pressure sensor from the air line fitting.
6. Remove the brake pressure sensor.

### Installation

1. Connect the brake pressure sensor to the air line or attach the sensor to the air line fitting.
2. Connect the wiring harness connector to the brake pressure sensor. Hand tighten only.
3. Remove the stands and blocks.
4. Test the installation.

### Test the Installation

To test the brake pressure sensor:

1. Turn the ignition on and verify that the ATC/ESC lamp operates correctly.
2. Start the vehicle and fully charge the reservoirs with air. Shut off the vehicle.
3. Apply the brakes and check for air leaks at the brake pressure sensor.
4. There should not be any active faults displayed in the ECU memory.

## 7 System Configurations

### 7.1 System Configurations System Configuration Layouts

The most common configurations are shown in this section. Always refer back to the vehicle OEM for the correct configuration of your vehicle.

Refer to Figure 7.1, Figure 7.2, Figure 7.3, Figure 7.4, Figure 7.5, Figure 7.6 and Figure 7.7 for system configuration layouts.

Fig. 7.1

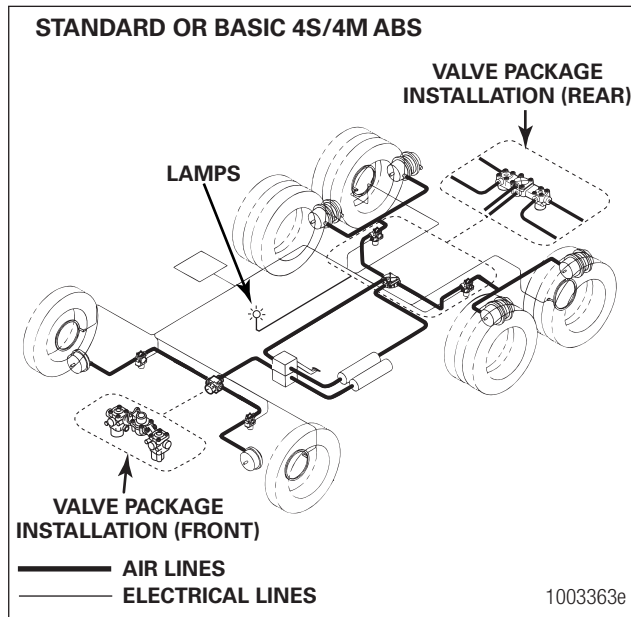
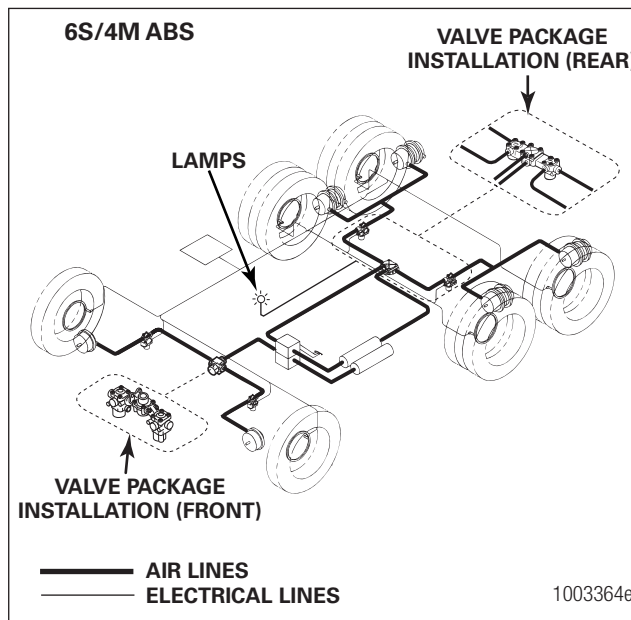


Fig. 7.2



# System Configurations

Fig. 7.3

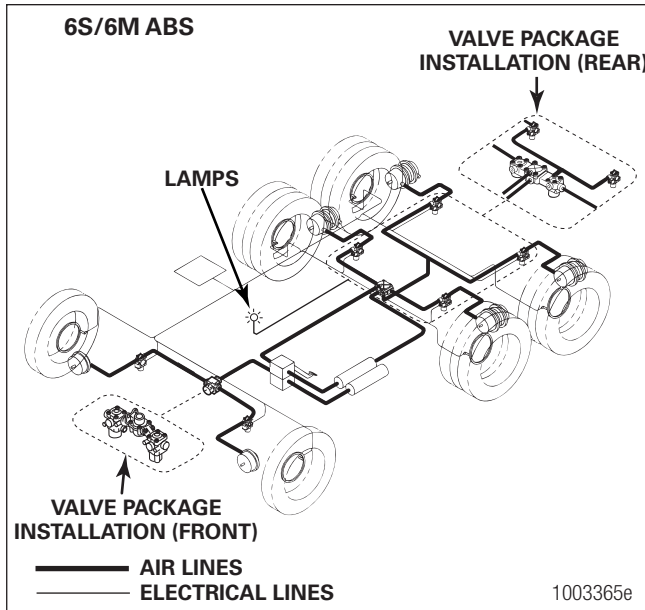
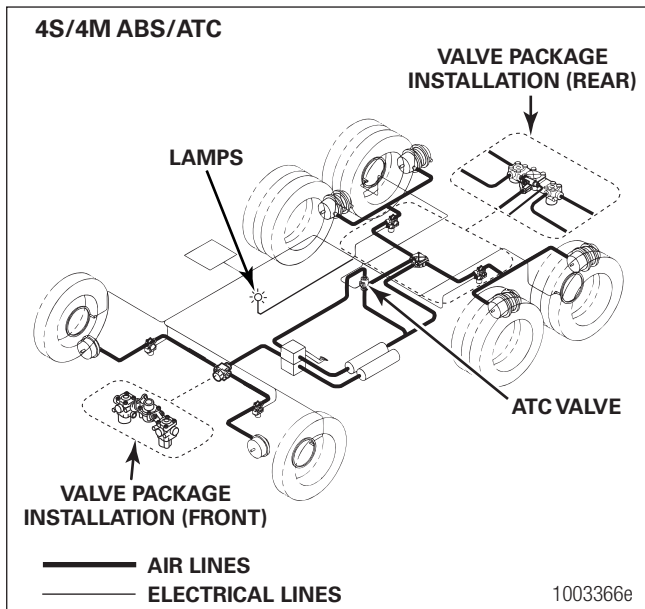


Fig. 7.4



# System Configurations

Fig. 7.5

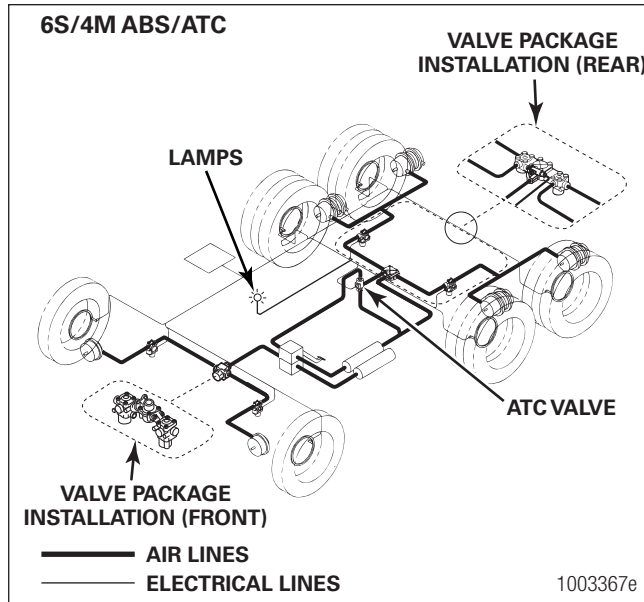
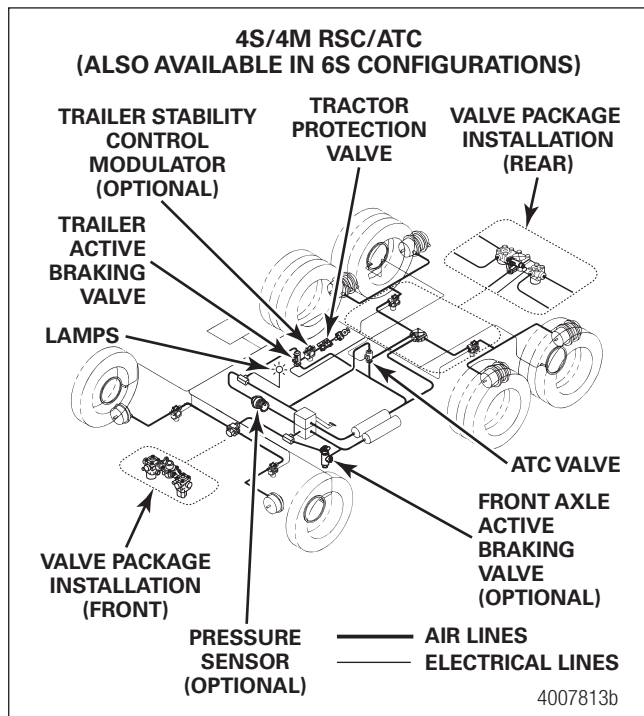
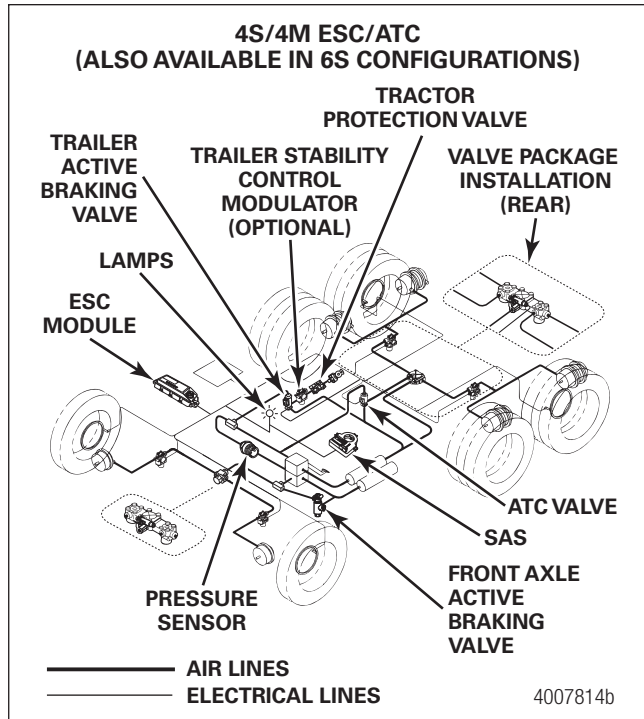


Fig. 7.6



# System Configurations

Fig. 7.7



## 8 Wiring Diagrams and Connectors

### 8.1 Wiring Diagrams and Connectors ECU Connector Pin Assignments

Refer to Figure 8.1, Figure 8.2, Figure 8.3, Figure 8.4, Figure 8.5, Figure 8.6, Figure 8.7, Figure 8.8, Figure 8.9, Figure 8.10, Figure 8.11, Figure 8.12, Figure 8.13, Figure 8.14, Figure 8.15 and Figure 8.16 for ECU wiring diagrams.

Fig. 8.1

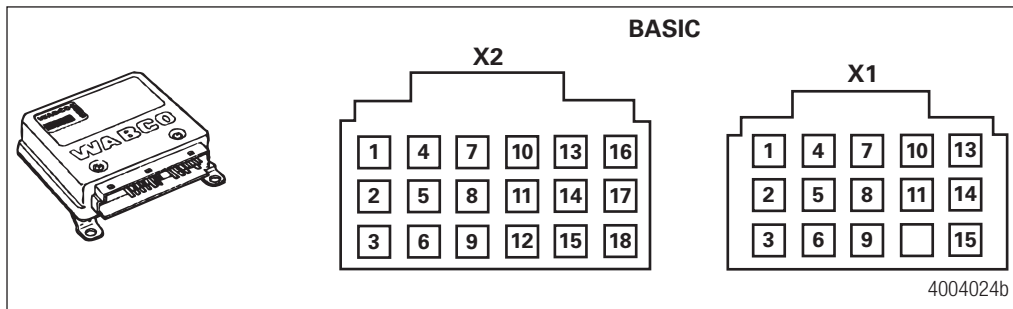


Fig. 8.2

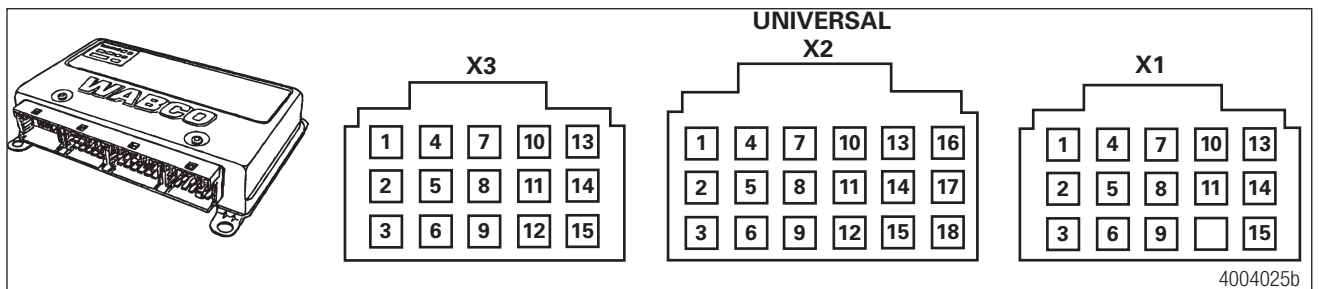
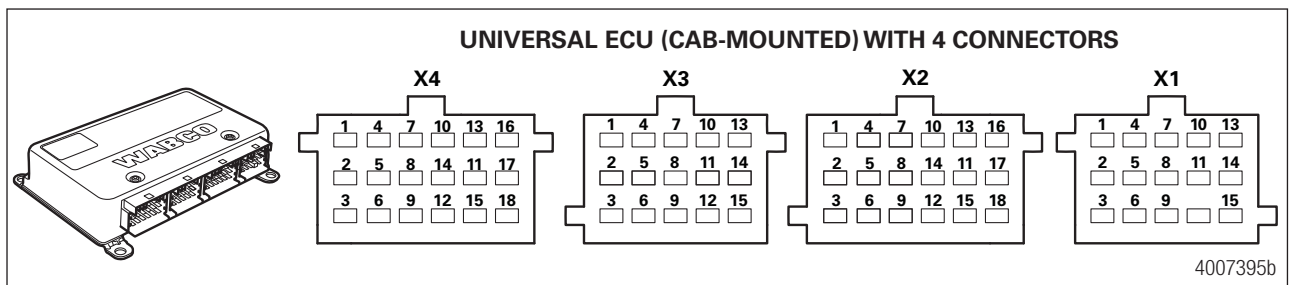


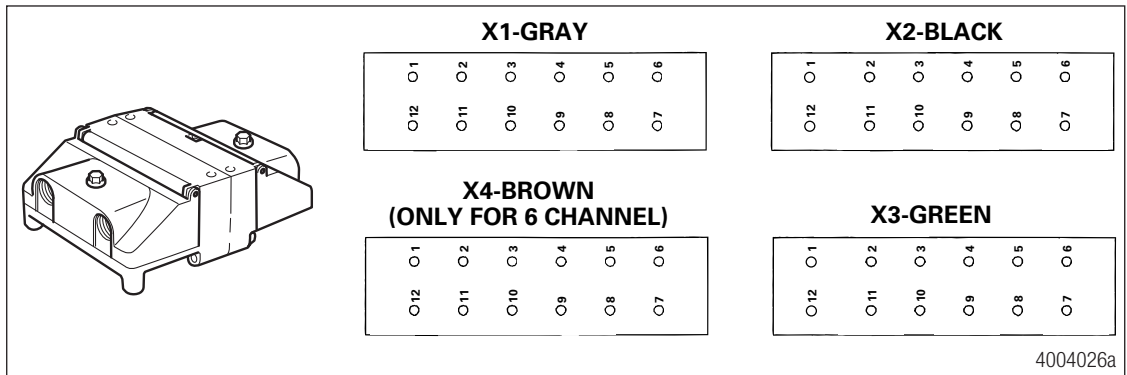
Fig. 8.3





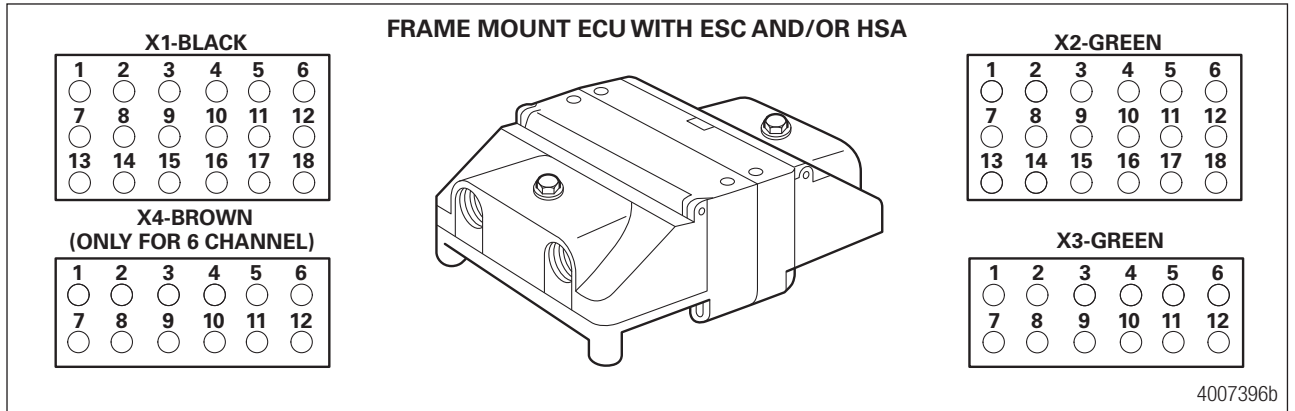
## 8.1.1 ECU (Frame-mounted)

Fig. 8.4



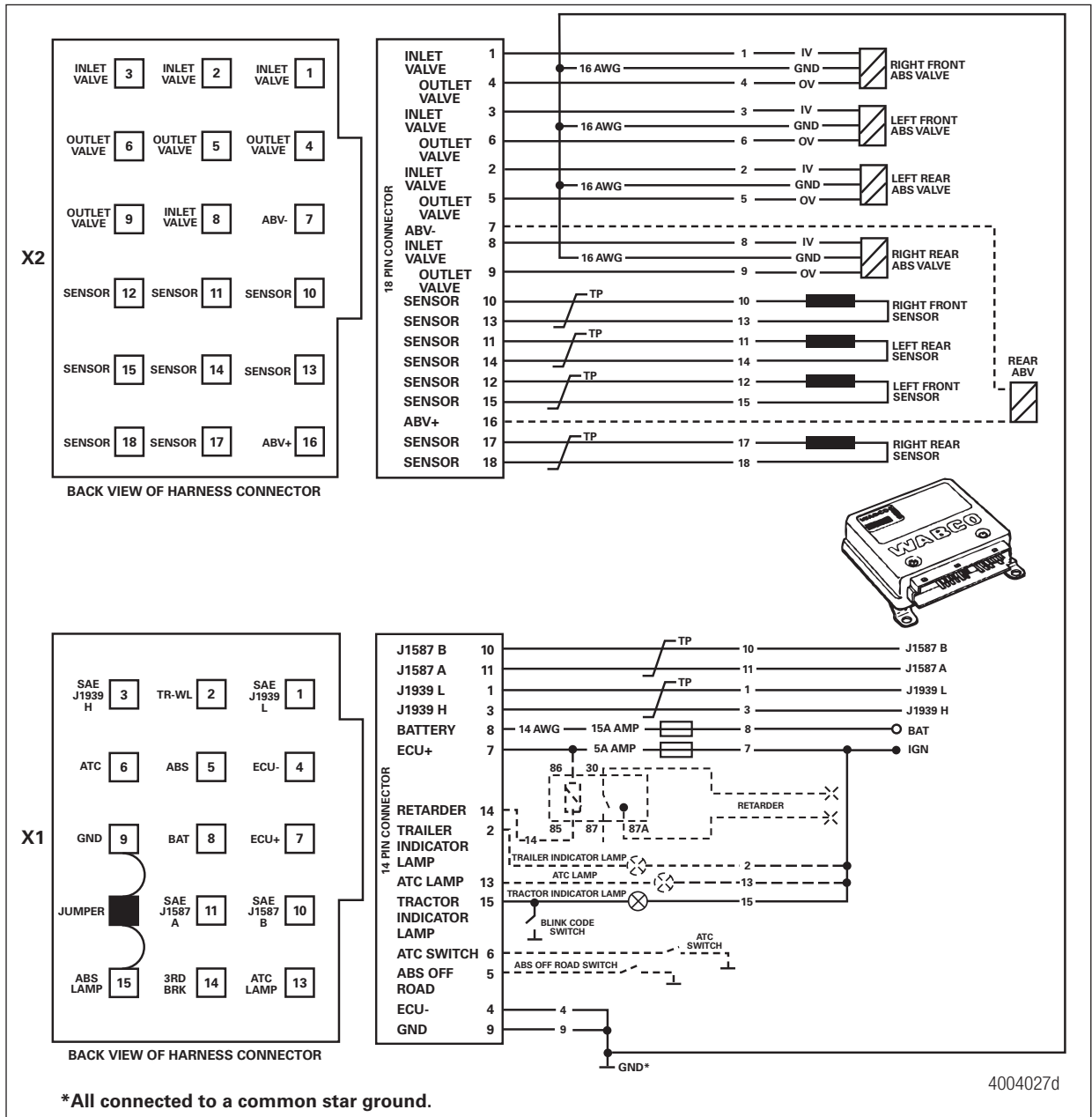
## 8.1.2 ECU (Frame-mounted) with ESC and/or HSA

Fig. 8.5



## 8.1.3 Basic ECU ABS Only with Optional Automatic Traction Control (ATC) (Cab-mounted)

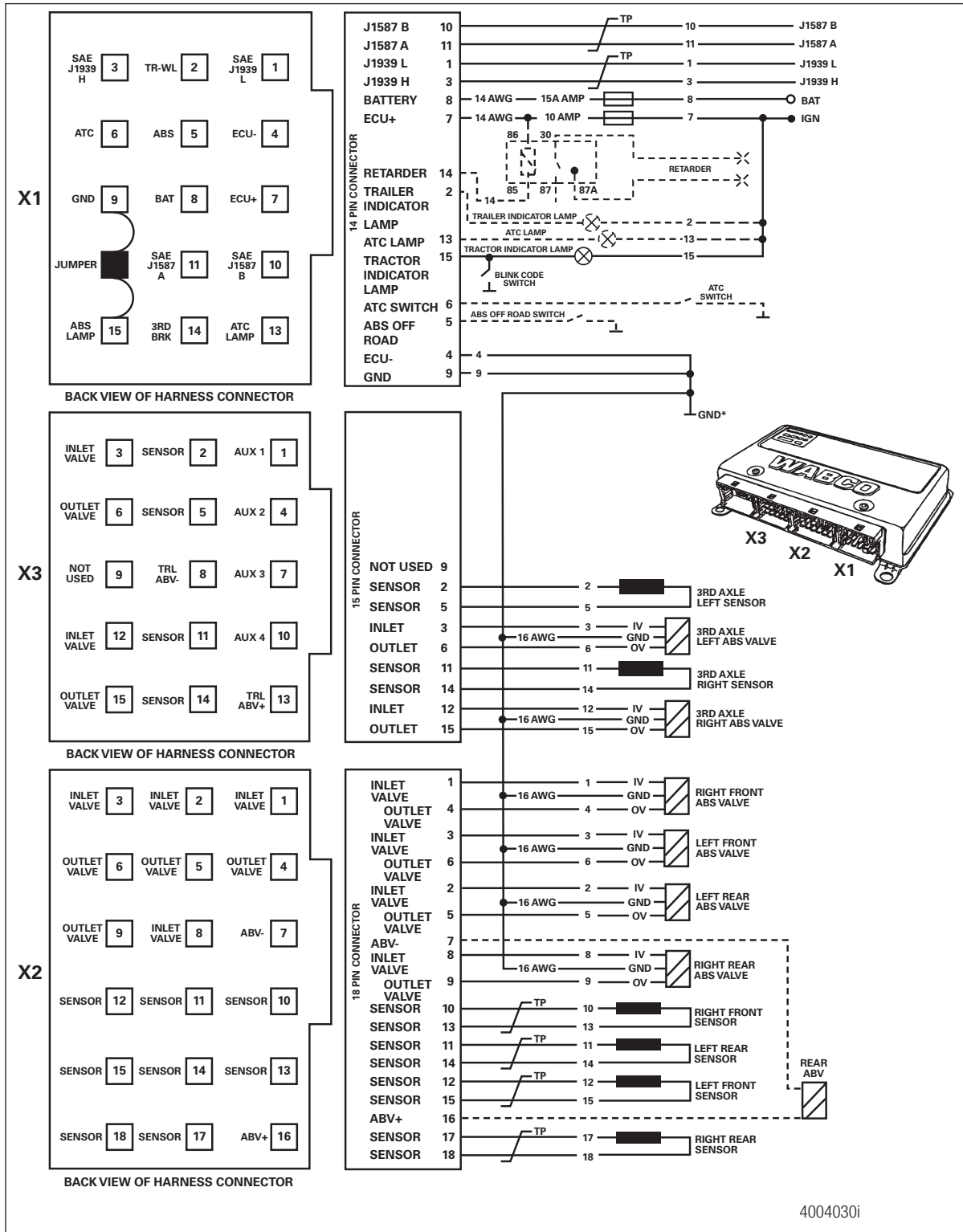
Fig. 8.6



# Wiring Diagrams and Connectors

## 8.1.3.1 6S/6M Universal ECU ABS Only with Optional Automatic Traction Control (ATC) (6S/4M and 4S/4M Configurations are also available)

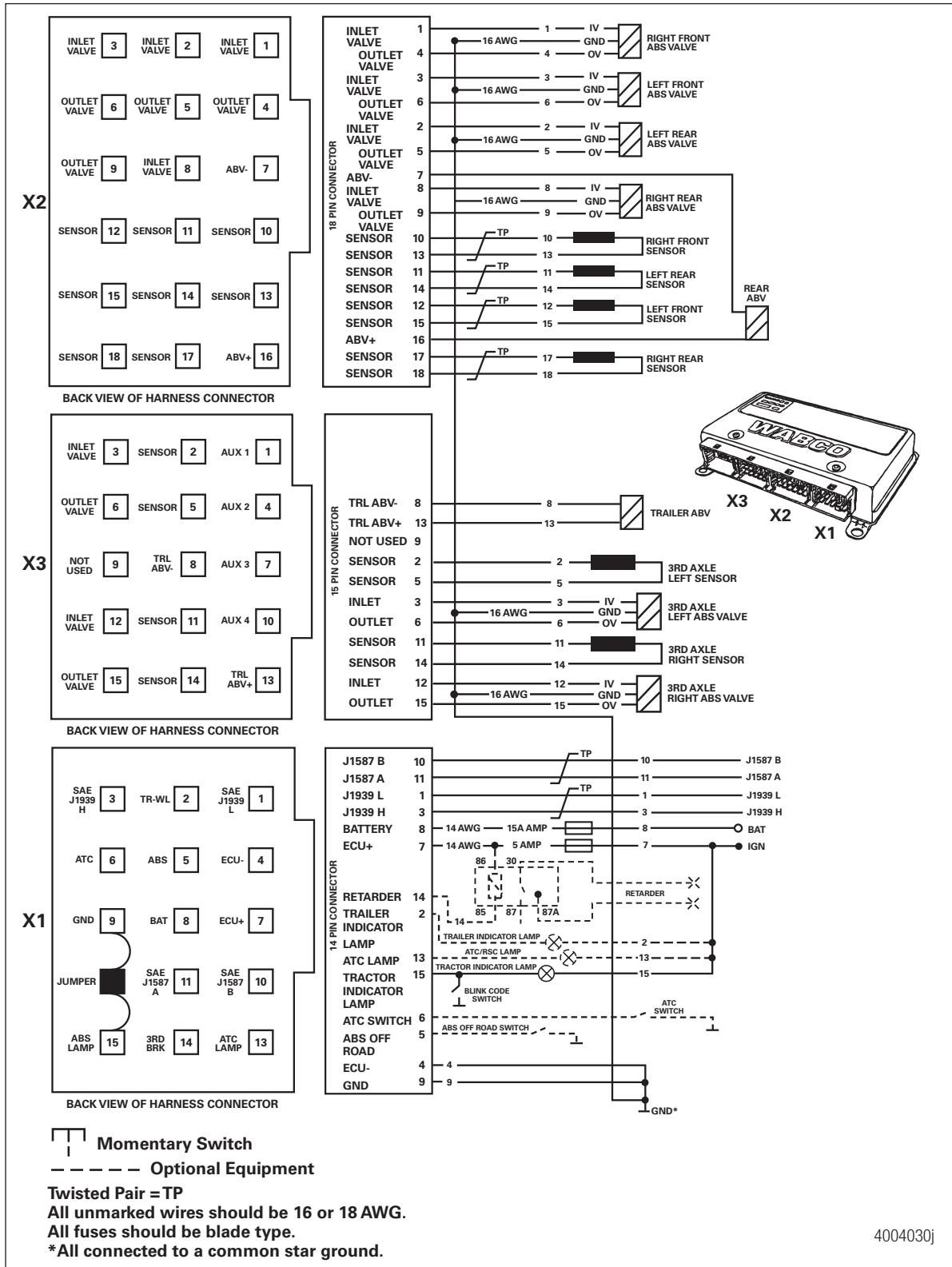
Fig. 8.7



# Wiring Diagrams and Connectors

## 8.1.3.2 6S/6M Universal ECU with Roll Stability Control (RSC) (6S/4M and 4S/4M Configurations are also available)

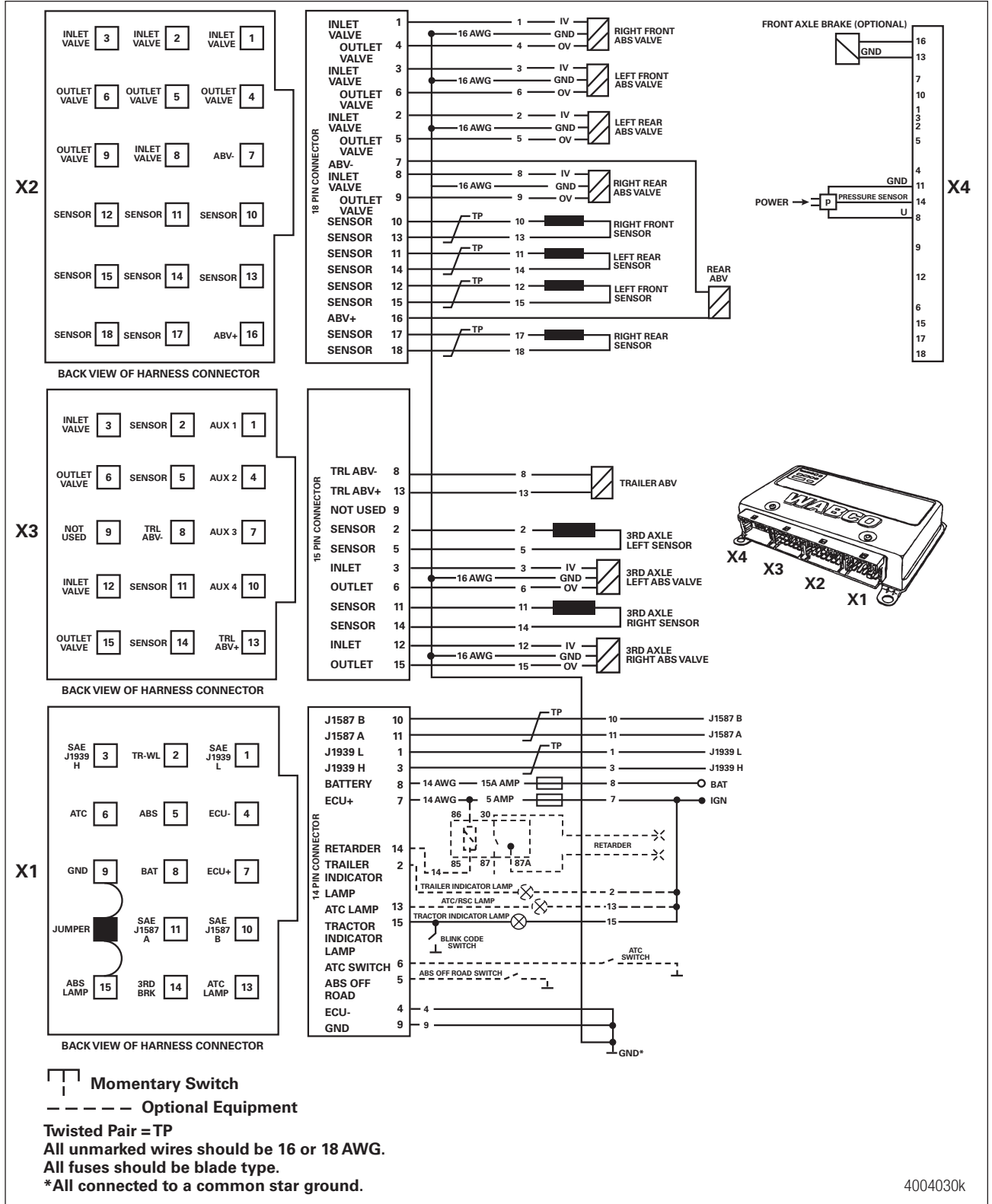
Fig. 8.8



# Wiring Diagrams and Connectors

## 8.1.3.3 6S/6M Universal ECU with RSC and Optional Front Axle Brake (6S/4M and 4S/4M Configurations are also available)

Fig. 8.9

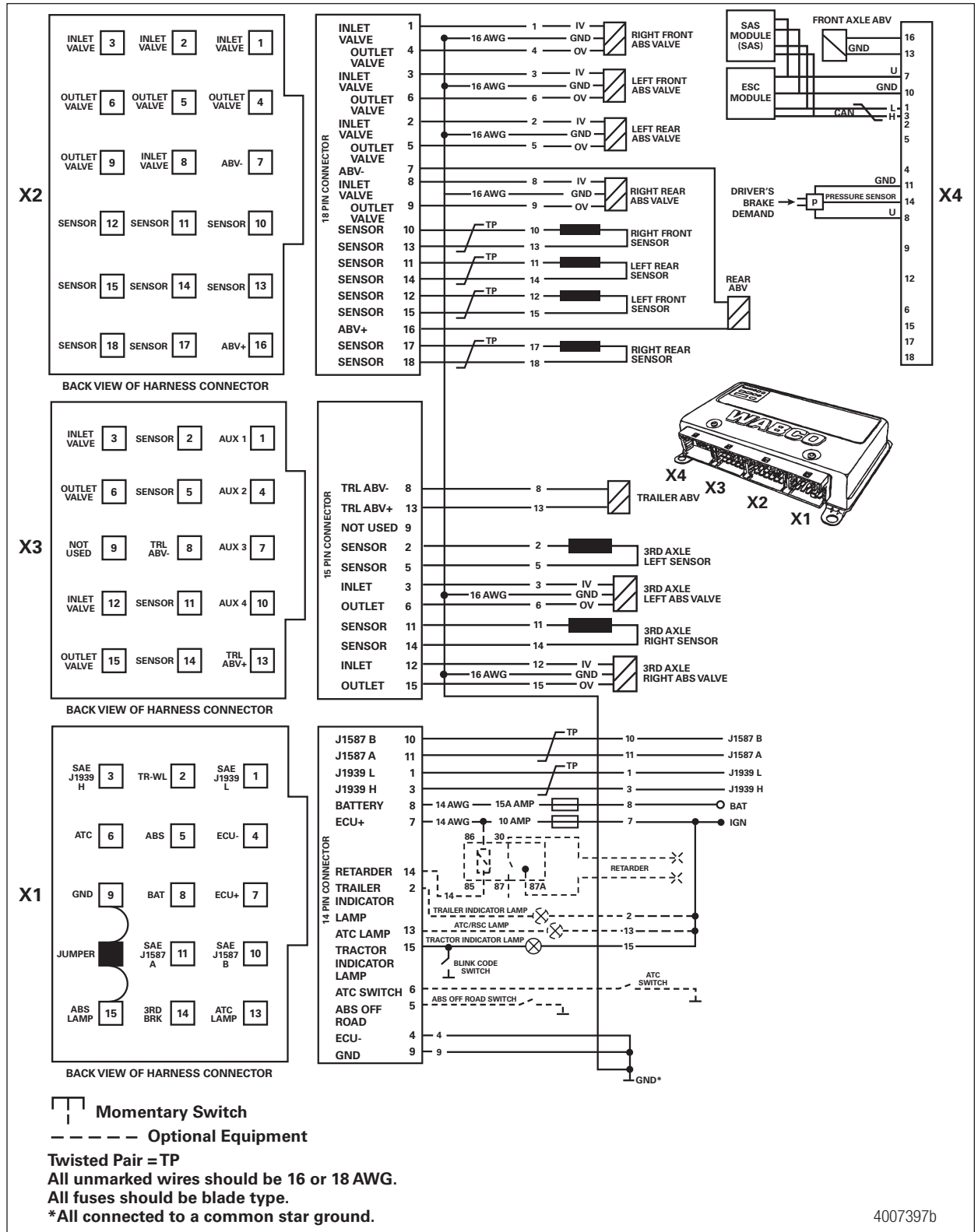


4004030k

# Wiring Diagrams and Connectors

## 8.1.3.4 6S/6M Universal ECU with Electronic Stability Control (ESC) (6S/4M and 4S/4M Configurations are also available)

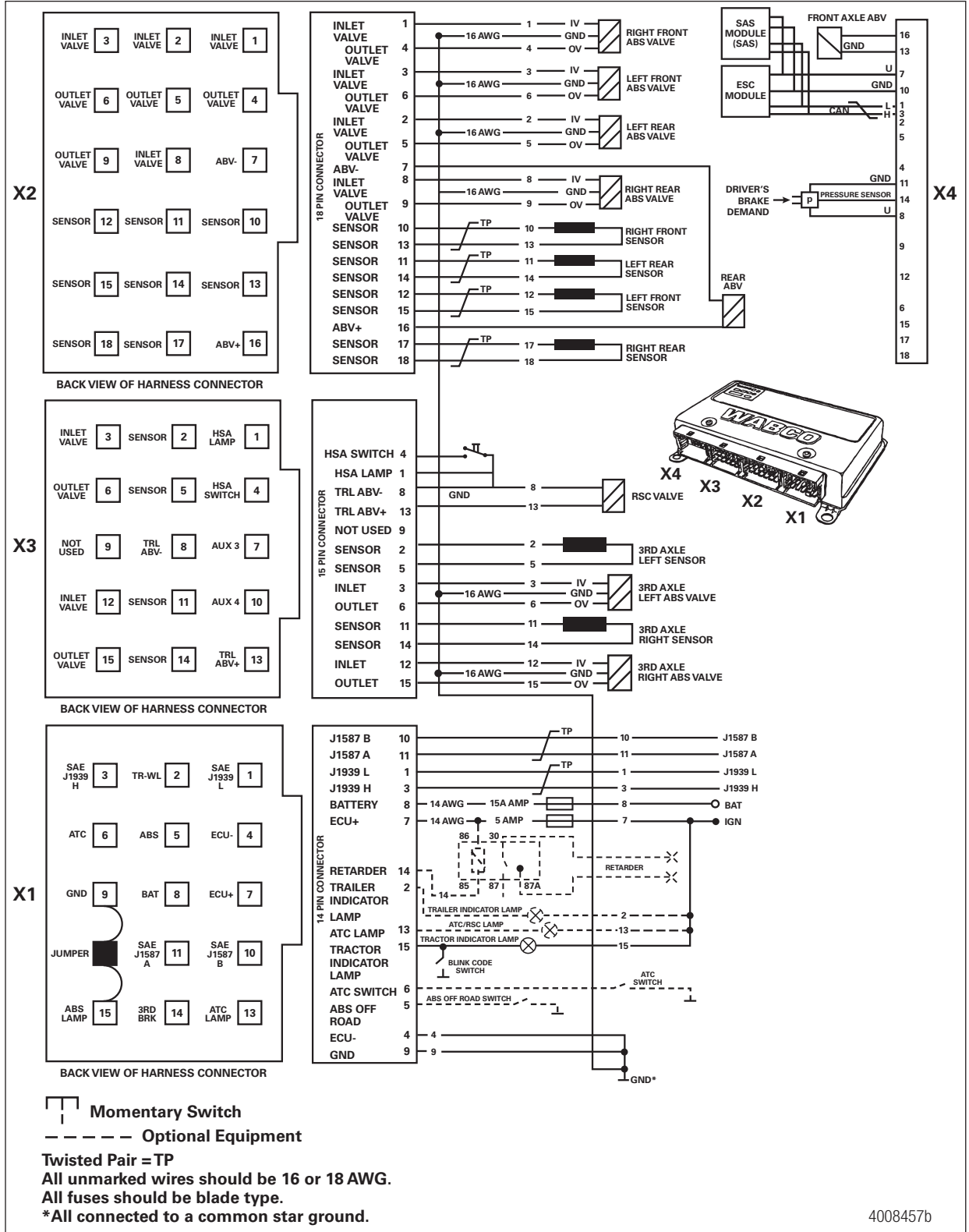
Fig. 8.10



# Wiring Diagrams and Connectors

## 8.1.3.5 6S/6M Universal ECU with ESC and Hill Start Aid (HSA) (6S/4M and 4S/4M Configurations are also available)

Fig. 8.11

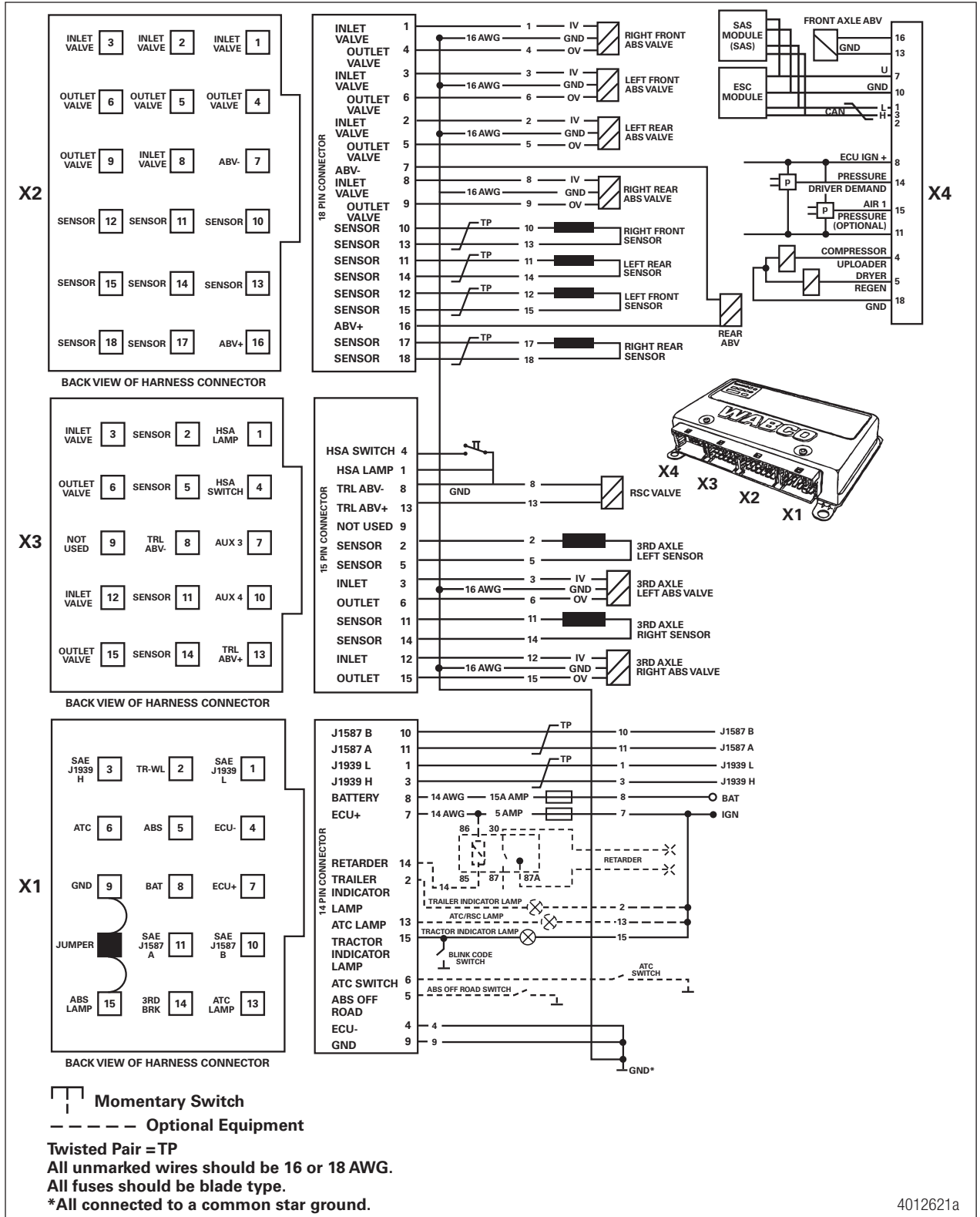


4008457b

# Wiring Diagrams and Connectors

## 8.1.3.6 6S/6M E8 Universal ECU with Electronic Stability Control (ESC), Hill Start Aid (HSA) and Electronic Air Processing (EAP) Function (6S/4M and 4S/4M Configurations are also available)

Fig. 8.12

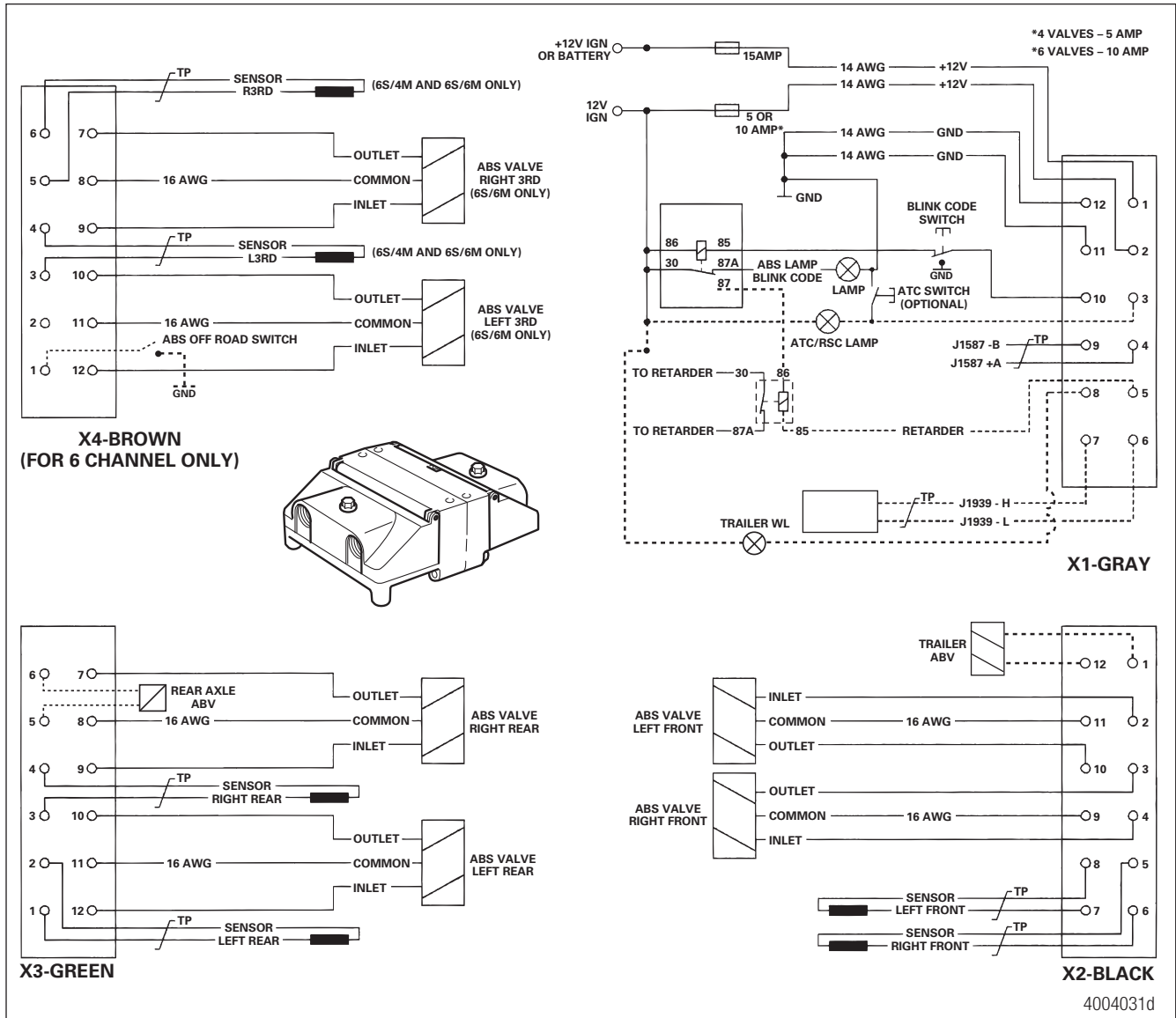




# Wiring Diagrams and Connectors

## 8.1.3.7 6S/6M Frame-mounted ECU ABS or RSC (6S/4M and 4S/4M Configurations are also available)

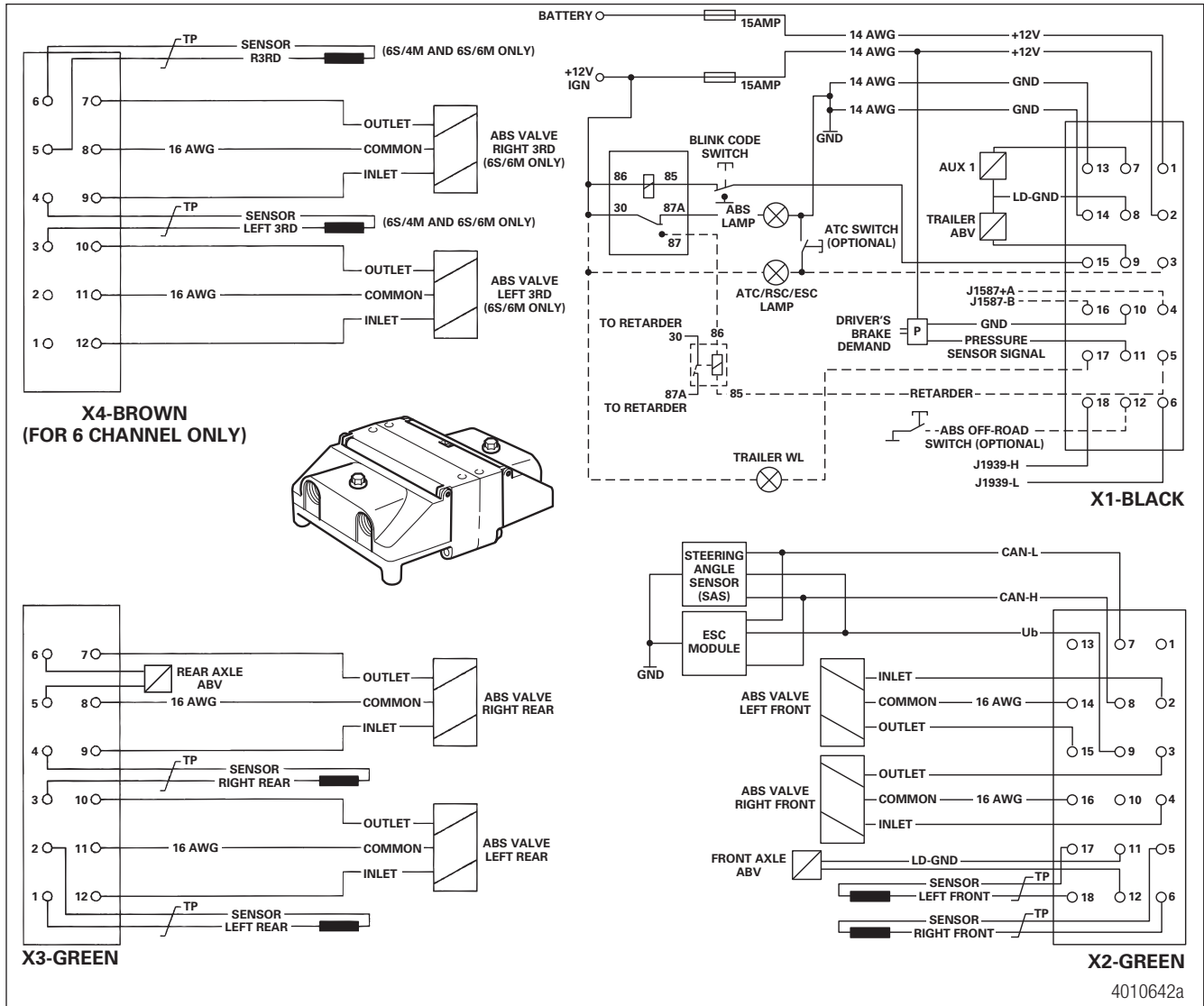
Fig. 8.13



# Wiring Diagrams and Connectors

## 8.1.3.8 6S/6M Frame-mounted ECU with ESC (6S/4M and 4S/4M Configurations are also available)

Fig. 8.14

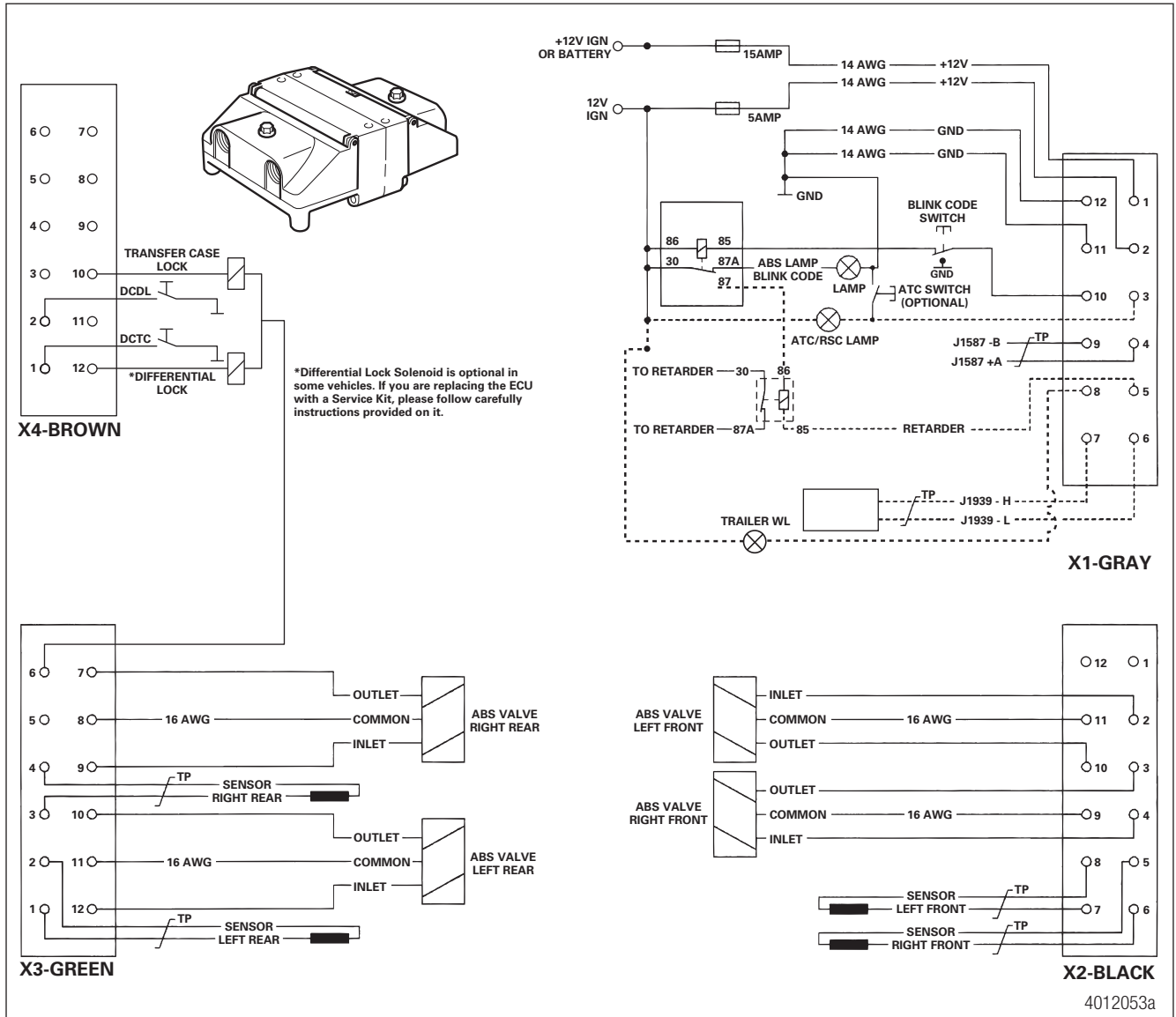


4010642a

# Wiring Diagrams and Connectors

## 8.1.3.9 4S/4M Frame-mounted ECU with Supervised-Lock-Control (SLC) Feature

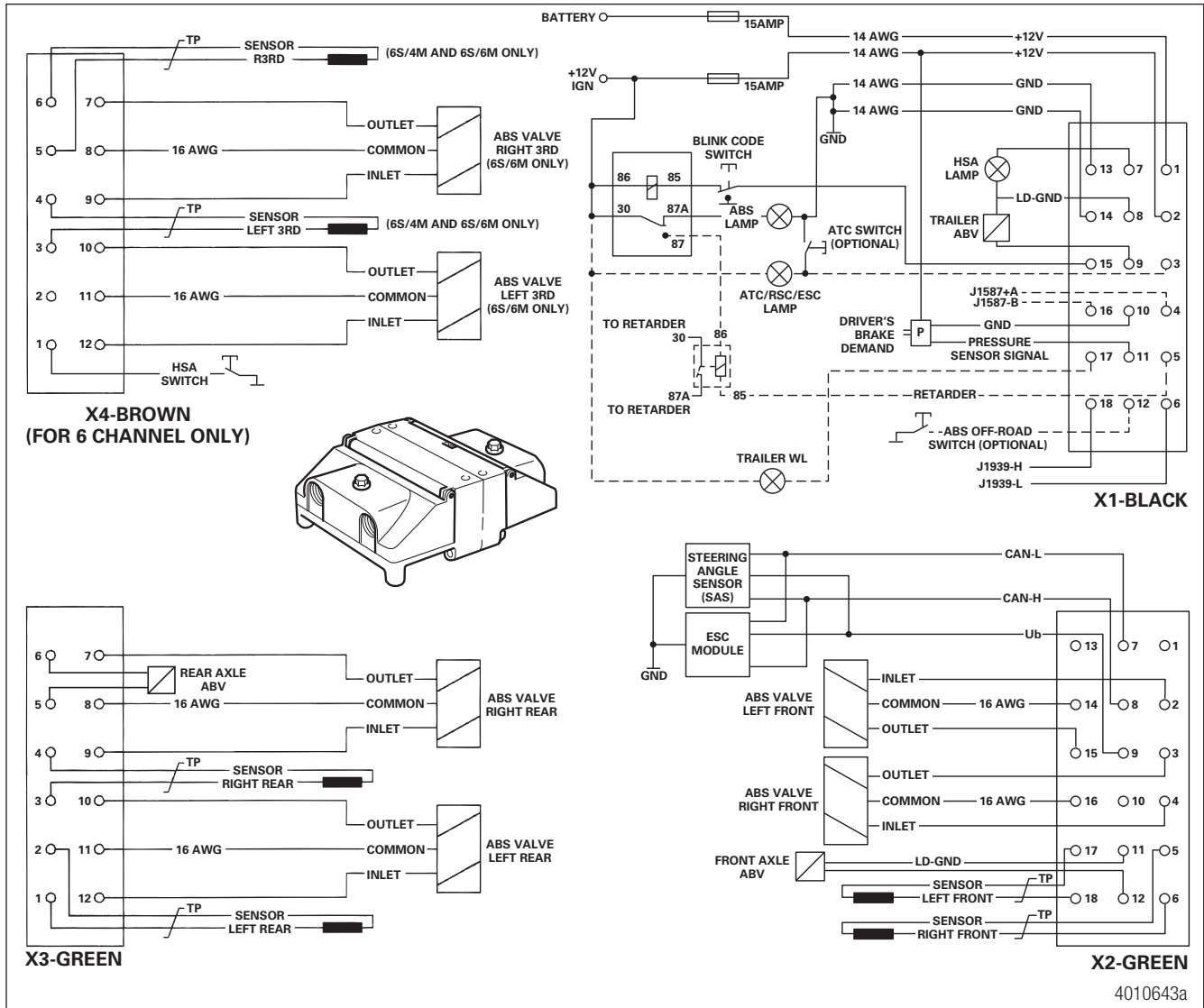
Fig. 8.15



# Wiring Diagrams and Connectors

## 8.1.3.10 6S/6M Frame-mounted ECU with ESC and Hill Start Aid (HSA) (6S/4M and 4S/4M with HSA and without ESC Configurations are also available)

Fig. 8.16



## 9 SPN, SID, FMI Fault Codes

### 9.1 SPN, SID, FMI Diagnostic Trouble Code List

Fig. 9.1

SPN	SID	FMI	Blink Code	Description	Warning Light	System Reaction	Cause	Action
<b>Left Front Wheel Speed Sensor</b>								
	0	1		TOOLBOX	ABS WL		ABS ECU not fully communicating with TOOLBOX	<ul style="list-style-type: none"> <li>• Check communication device connections.</li> <li>• Verify protocol (J1708/J1939) was not changed on the same key cycle.</li> <li>• Verify RP1012A compliant device, and verify the device software and firmware are up to date.</li> <li>• Check data link connector for issues.</li> </ul>
789	1	1	3 + 2	Air Gap	ABS WL	ABS Wheel Disabled ESC/RSC/ATC/ HSA Disabled	Sensor air gap is too large; sensor output voltage is too low but is high enough to be read by ECU.	<ul style="list-style-type: none"> <li>• Adjust wheel sensor to touch tone ring.</li> <li>• Check condition of ABS sensor head.</li> <li>• Check for loose wheel bearings or excessive hub runout.</li> <li>• Check mounting of ABS tone ring and condition of teeth.</li> <li>• Check condition and retention of ABS sensor spring clip.</li> <li>• Check ABS sensor cable routing and clipping.</li> <li>• Turn the wheel at half a revolution per second and verify 0.2 AC volt sensor output voltage.</li> </ul>
789	1	2	5 + 2	Incorrect Tire	ABS WL	ABS Wheel Disabled ESC/RSC/ATC/ HSA Disabled	System has detected a significant difference in the proportion of tire diameter to number of tone ring teeth between wheel ends. 10% (+/-2%)	<ul style="list-style-type: none"> <li>• Check for tire size mismatch.</li> <li>• Check for correct number of tone ring teeth.</li> <li>• Verify that ECU is programmed for the correct vehicle.</li> </ul>
789	1	3	4 + 2	Shorted to UBATT	ABS WL	ABS Wheel Disabled ESC/RSC/ATC/ HSA Disabled	Continuity between the sensor connection and battery voltage (short circuit) is detected.	<ul style="list-style-type: none"> <li>• Verify 900-2000 ohms resistance through sensor circuit.</li> <li>• Verify no DC voltage through sensor circuit Key ON.</li> <li>• Check for corroded or damaged wiring between the ECU and the ABS wheel speed sensor.</li> </ul>
789	1	4	4 + 2	Shorted to Ground	ABS WL	ABS Wheel Disabled ESC/RSC/ATC/ HSA Disabled	Continuity between the sensor connection and ground (short circuit) is detected.	<ul style="list-style-type: none"> <li>• Verify 900-2000 ohms resistance through sensor circuit.</li> <li>• Check for continuity between the ABS sensor connection and ground.</li> <li>• Check for corroded or damaged wiring between the ECU and the ABS wheel speed sensor.</li> <li>• Verify wheel speed sensor wires are not switched left/right.</li> </ul>
789	1	5	4 + 2	Open Circuit	ABS WL	ABS Wheel Disabled ESC/RSC/ATC/ HSA Disabled	An open circuit has been detected, i.e. ECU detects a disconnected wheel speed sensor.	<ul style="list-style-type: none"> <li>• Check sensor, sensor cable and connectors to verify no loose or damaged connection.</li> <li>• Verify 900-2000 ohms resistance through sensor circuit.</li> <li>• Verify wheel speed sensor wires are not switched left/right.</li> </ul>
789	1	6	4 + 2	Short Circuit	ABS WL	ABS Wheel Disabled ESC/RSC/ATC/ HSA Disabled	Continuity interruption between the sensor connections (short circuit) has been detected.	<ul style="list-style-type: none"> <li>• Verify 900-2000 ohms resistance through sensor circuit.</li> <li>• Check for corroded or damaged wiring between the ECU and the ABS wheel speed sensor.</li> </ul>

4010644a

# SPN, SID, FMI Fault Codes

Fig. 9.2

SPN	SID	FMI	Blink Code	Description	Warning Light	System Reaction	Cause	Action
789	1	7	6 + 2	Incorrect Tone Ring	ABS WL	ABS Wheel Disabled ESC/RSC/ATC/ HSA Disabled	Wheel speed signal drops out periodically at speeds higher than 6 mph.	<ul style="list-style-type: none"> <li>• Check for damaged or missing teeth on tone ring.</li> <li>• Verify tone ring is not corroded or with contamination.</li> </ul>
789	1	8	3 + 2	Excessive Slip	ABS WL	ABS Wheel Disabled ESC/RSC/ATC/ HSA Disabled	Wheel slip over 16 seconds continuously has been detected.	<ul style="list-style-type: none"> <li>• Adjust wheel sensor to touch tooth wheel.</li> <li>• Check sensor gap.</li> <li>• Check for loose wheel bearings or excessive hub runout.</li> </ul>
789	1	9	5 + 2	Wires Mismatched	ABS WL	ABS Wheel Disabled ESC/RSC/ATC/ HSA Disabled	A sensor lead from an incorrect wheel end has been detected.	<ul style="list-style-type: none"> <li>• Check for mismatch fault of another sensor.</li> <li>• Verify correct harness location and wiring for sensor.</li> <li>• Check for corroded or damaged wiring between the ECU and the ABS wheel speed sensor.</li> </ul>
789	1	10	3 + 2	Speed Drop-Out	ABS WL	ABS Wheel Disabled ESC/RSC/ATC/ HSA Disabled	A temporary loss of the ABS wheel speed signal has been detected.	<ul style="list-style-type: none"> <li>• Adjust wheel speed sensor until it touches the tone ring.</li> <li>• Check for loose wheel bearings or excessive hub runout.</li> <li>• Check sensor wiring and connectors for intermittent contact.</li> <li>• Check condition of ABS sensor head.</li> <li>• Check mounting of tone ring and condition of teeth.</li> <li>• Check condition and retention of ABS sensor or spring clip.</li> <li>• Check ABS sensor cable routing and clipping.</li> <li>• Check for corroded or damaged wiring between the ECU and the ABS wheel speed sensor.</li> <li>• Turn the wheel at half a revolution per second and verify 0.2 AC volt sensor output voltage.</li> </ul>
789	1	11	5 + 2	Abnormal Speed (Chatter)	ABS WL	ABS Wheel Disabled ESC/RSC/ATC/ HSA Disabled	Brake drag or chatter has been detected. Abnormal vibrations detected which affect sensor signal.	<ul style="list-style-type: none"> <li>• Check for loose wheel bearings or excessive hub runout.</li> <li>• Check sensor wiring and connectors for intermittent contact.</li> <li>• Check mounting of tone ring and condition of teeth.</li> <li>• Check condition and retention of ABS sensor spring clip as well as the mounting block.</li> <li>• Check for corroded or damaged wiring between the ECU and the ABS wheel speed sensor.</li> <li>• Turn the wheel at half a revolution per second and verify 0.2 AC volt sensor output voltage.</li> </ul>
789	1	12	5 + 2	Frequency Too High	ABS WL	ABS Wheel Disabled ESC/RSC/ATC/ HSA Disabled	A non-plausible sensor frequency has been measured.	<ul style="list-style-type: none"> <li>• Check sensor wiring and connectors for intermittent contact.</li> <li>• Check if brake at this location is operating correctly, i.e., potentially dragging.</li> <li>• Check for corroded or damaged wiring between the ECU and the ABS wheel speed sensor.</li> </ul>
789	1	13	N/A	Brake Performance issue LF,RR, L3rd	ATC WL	N/A	Brake performance monitor condition exceeded.	<ul style="list-style-type: none"> <li>• Check the foundation brakes for all wheel ends.</li> </ul>

4010645a

# SPN, SID, FMI Fault Codes

Fig. 9.3

SPN	SID	FMI	Blink Code	Description	Warning Light	System Reaction	Cause	Action
<b>Right Front Wheel Speed Sensor</b>								
790	2	1	3 + 1	Air Gap	ABS WL	ABS Wheel Disabled ESC/RSC/ATC/ HSA Disabled	Sensor air gap is too large, sensor output voltage is too low but is high enough to be read by ECU.	<ul style="list-style-type: none"> <li>Adjust wheel sensor to touch tone ring.</li> <li>Check condition of ABS sensor head.</li> <li>Check for loose wheel bearings or excessive hub runout.</li> <li>Check mounting of ABS tone ring and condition of teeth.</li> <li>Check condition and retention of ABS sensor spring clip.</li> <li>Check ABS sensor cable routing and clipping.</li> <li>Turn the wheel at half a revolution per second and verify 0.2 AC volt sensor output voltage.</li> </ul>
790	2	2	5 + 1	Incorrect Tire	ABS WL	ABS Wheel Disabled ESC/RSC/ATC/ HSA Disabled	System has detected a significant difference in the proportion of tire diameter to number of tone ring teeth between wheel ends. 10% (+/-2%)	<ul style="list-style-type: none"> <li>Check for tire size mismatch.</li> <li>Check for correct number of tone ring teeth.</li> <li>Verify that ECU is programmed for the correct vehicle.</li> <li>Contact WABCO or OEM.</li> </ul>
790	2	3	4 + 1	Shorted to UBATT	ABS WL	ABS Wheel Disabled ESC/RSC/ATC/ HSA Disabled	Continuity between the sensor connection and battery voltage (short circuit) is detected.	<ul style="list-style-type: none"> <li>Verify 900-2000 ohms resistance through sensor circuit.</li> <li>Verify no DC voltage through sensor circuit Key ON.</li> <li>Check for corroded or damaged wiring between the ECU and the ABS wheel speed sensor.</li> </ul>
790	2	4	4 + 1	Shorted to Ground	ABS WL	ABS Wheel Disabled ESC/RSC/ATC/ HSA Disabled	Continuity between the sensor connection and ground (short circuit) is detected.	<ul style="list-style-type: none"> <li>Verify 900-2000 ohms resistance through sensor circuit.</li> <li>Check for continuity between the ABS sensor connection and ground.</li> <li>Check for corroded or damaged wiring between the ECU and the ABS wheel speed sensor.</li> <li>Verify wheel speed sensor wires are not switched left/right.</li> </ul>
790	2	5	4 + 2	Open Circuit	ABS WL	ABS Wheel Disabled ESC/RSC/ATC/ HSA Disabled	An open circuit has been detected, i.e. ECU detects a disconnected wheel speed sensor.	<ul style="list-style-type: none"> <li>Check sensor, sensor cable and connectors to verify no loose or damaged connection.</li> <li>Verify 900-2000 ohms resistance through sensor circuit.</li> <li>Verify wheel speed sensor wires are not switched left/right.</li> </ul>
790	2	6	4 + 1	Short Circuit	ABS WL	ABS Wheel Disabled ESC/RSC/ATC/ HSA Disabled	Continuity interruption between the sensor connections (short circuit) has been detected.	<ul style="list-style-type: none"> <li>Verify 900-2000 ohms resistance through sensor circuit.</li> <li>Check for corroded or damaged wiring between the ECU and the ABS wheel speed sensor.</li> </ul>

4010646a

# SPN, SID, FMI Fault Codes

Fig. 9.4

SPN	SID	FMI	Blink Code	Description	Warning Light	System Reaction	Cause	Action
790	2	7	6 + 1	Incorrect Tone Ring	ABS WL	ABS Wheel Disabled ESC/RSC/ATC/ HSA Disabled	Wheel speed signal drops out periodically at speeds higher than 6 mph.	<ul style="list-style-type: none"> <li>• Check for damaged or missing teeth on tone ring.</li> <li>• Verify tone ring is not corroded or with contamination.</li> </ul>
790	2	8	3 + 1	Excessive Slip	ABS WL	ABS Wheel Disabled ESC/RSC/ATC/ HSA Disabled	Wheel slip over 16 seconds continuously has been detected.	<ul style="list-style-type: none"> <li>• Adjust wheel sensor to touch tooth wheel.</li> <li>• Check sensor gap.</li> <li>• Check for loose wheel bearings or excessive hub runout.</li> </ul>
790	2	9	5 + 1	Wires Mismatched	ABS WL	ABS Wheel Disabled ESC/RSC/ATC/ HSA Disabled	A sensor lead from an incorrect wheel end has been detected.	<ul style="list-style-type: none"> <li>• Check for mismatch fault of another sensor.</li> <li>• Verify correct harness location and wiring for sensor.</li> <li>• Check for corroded or damaged wiring between the ECU and the ABS wheel speed sensor.</li> </ul>
790	2	10	3 + 1	Speed Drop-Out	ABS WL	ABS Wheel Disabled ESC/RSC/ATC/ HSA Disabled	A temporary loss of the ABS wheel speed signal has been detected.	<ul style="list-style-type: none"> <li>• Adjust wheel speed sensor until it touches the tone ring.</li> <li>• Check for loose wheel bearings or excessive hub runout.</li> <li>• Check sensor wiring and connectors for intermittent contact.</li> <li>• Check condition of ABS sensor head.</li> <li>• Check mounting of tone ring and condition of teeth.</li> <li>• Check condition and retention of ABS sensor spring clip.</li> <li>• Check ABS sensor cable routing and clipping.</li> <li>• Check for corroded or damaged wiring between the ECU and the ABS wheel speed sensor.</li> <li>• Turn the wheel at half a revolution per second and verify 0.2 AC volt sensor output voltage.</li> </ul>
790	2	11	5 + 1	Abnormal Speed (Chatter)	ABS WL	ABS Wheel Disabled ESC/RSC/ATC/ HSA Disabled	Brake drag or chatter has been detected. Abnormal vibrations detected which affect sensor signal.	<ul style="list-style-type: none"> <li>• Check for loose wheel bearings or excessive hub runout.</li> <li>• Check sensor wiring and connectors for intermittent contact.</li> <li>• Check mounting of tone ring and condition of teeth.</li> <li>• Check condition and retention of ABS sensor spring clip as well as the mounting block.</li> <li>• Check for corroded or damaged wiring between the ECU and the ABS wheel speed sensor.</li> <li>• Turn the wheel at half a revolution per second and verify 0.2 AC volt sensor output voltage.</li> </ul>
790	2	12	5 + 1	Frequency Too High	ABS WL	ABS Wheel Disabled ESC/RSC/ATC/ HSA Disabled	A non-plausible sensor frequency has been measured.	<ul style="list-style-type: none"> <li>• Check sensor wiring and connectors for intermittent contact.</li> <li>• Check if brake at this location is operating correctly, i.e., potentially dragging.</li> <li>• Check for corroded or damaged wiring between the ECU and the ABS wheel speed sensor.</li> </ul>

4010647a



# SPN, SID, FMI Fault Codes

Fig. 9.5

SPN	SID	FMI	Blink Code	Description	Warning Light	System Reaction	Cause	Action
<b>Left Rear Wheel Speed Sensor</b>								
791	3	1	3 + 4	Air Gap	ABS WL	ABS Wheel Disabled ESC/RSC/ATC/ HSA Disabled	Sensor air gap is too large, sensor output voltage is too low but is high enough to be read by ECU.	<ul style="list-style-type: none"> <li>Adjust wheel sensor to touch tone ring.</li> <li>Check condition of ABS sensor head.</li> <li>Check for loose wheel bearings or excessive hub runout.</li> <li>Check mounting of ABS tone ring and condition of teeth.</li> <li>Check condition and retention of ABS sensor spring clip.</li> <li>Check ABS sensor cable routing and clipping.</li> <li>Turn the wheel at half a revolution per second and verify 0.2 AC volt sensor output voltage.</li> </ul>
791	3	2	5 + 4	Incorrect Tire	ABS WL	ABS Wheel Disabled ESC/RSC/ATC/ HSA Disabled	System has detected a significant difference in the proportion of tire diameter to number of tone ring teeth between wheel ends. 10% (+/-2%)	<ul style="list-style-type: none"> <li>Check for tire size mismatch.</li> <li>Check for correct number of tone ring teeth.</li> <li>Verify that ECU is programmed for the correct vehicle.</li> </ul>
791	3	3	4 + 4	Shorted to UBATT	ABS WL	ABS Wheel Disabled ESC/RSC/ATC/ HSA Disabled	Continuity between the sensor connection and battery voltage (short circuit) is detected.	<ul style="list-style-type: none"> <li>Verify 900-2000 ohms resistance through sensor circuit.</li> <li>Verify no DC voltage through sensor circuit Key ON.</li> <li>Check for corroded or damaged wiring between the ECU and the ABS wheel speed sensor.</li> </ul>
791	3	4	4 + 4	Shorted to Ground	ABS WL	ABS Wheel Disabled ESC/RSC/ATC/ HSA Disabled	Continuity between the sensor connection and ground (short circuit) is detected.	<ul style="list-style-type: none"> <li>Verify 900-2000 ohms resistance through sensor circuit.</li> <li>Check for continuity between the ABS sensor connection and ground.</li> <li>Check for corroded or damaged wiring between the ECU and the ABS wheel speed sensor.</li> <li>Verify wheel speed sensor wires are not switched left/right.</li> </ul>
791	3	5	4 + 4	Open Circuit	ABS WL	ABS Wheel Disabled ESC/RSC/ATC/ HSA Disabled	An open circuit has been detected, i.e. ECU detects a disconnected wheel speed sensor.	<ul style="list-style-type: none"> <li>Check sensor, sensor cable and connectors to verify no loose or damaged connection.</li> <li>Verify 900-2000 ohms resistance through sensor circuit.</li> <li>Verify wheel speed sensor wires are not switched left/right.</li> </ul>
791	3	6	4 + 4	Short Circuit	ABS WL	ABS Wheel Disabled ESC/RSC/ATC/ HSA Disabled	Continuity interruption between the sensor connections (short circuit) has been detected.	<ul style="list-style-type: none"> <li>Verify 900-2000 ohms resistance through sensor circuit.</li> <li>Check for corroded or damaged wiring between the ECU and the ABS wheel speed sensor.</li> </ul>

4010648a

# SPN, SID, FMI Fault Codes

Fig. 9.6

SPN	SID	FMI	Blink Code	Description	Warning Light	System Reaction	Cause	Action
791	3	7	6 + 4	Incorrect Tone Ring	ABS WL	ABS Wheel Disabled ESC/RSC/ATC/ HSA Disabled	Wheel speed signal drops out periodically at speeds higher than 6 mph.	<ul style="list-style-type: none"> <li>Check for damaged or missing teeth on tone ring.</li> <li>Verify tone ring is not corroded or with contamination.</li> </ul>
791	3	8	3 + 4	Excessive Slip	ABS WL	ABS Wheel Disabled ESC/RSC/ATC/ HSA Disabled	Wheel slip over 16 seconds continuously has been detected.	<ul style="list-style-type: none"> <li>Adjust wheel sensor to touch tooth wheel.</li> <li>Check sensor gap.</li> <li>Check for loose wheel bearings or excessive hub runout.</li> </ul>
791	3	9	5 + 4	Wires Mismatched	ABS WL	ABS Wheel Disabled ESC/RSC/ATC/ HSA Disabled	A sensor lead from an incorrect wheel end has been detected.	<ul style="list-style-type: none"> <li>Check for mismatch fault of another sensor.</li> <li>Verify correct harness location and wiring for sensor.</li> <li>Check for corroded or damaged wiring between the ECU and the ABS wheel speed sensor.</li> </ul>
791	3	10	3 + 4	Speed Drop-Out	ABS WL	ABS Wheel Disabled ESC/RSC/ATC/ HSA Disabled	A temporary loss of the ABS wheel speed signal has been detected.	<ul style="list-style-type: none"> <li>Adjust wheel speed sensor until it touches the tone ring.</li> <li>Check for loose wheel bearings or excessive hub runout.</li> <li>Check sensor wiring and connectors for intermittent contact.</li> <li>Check condition of ABS sensor head.</li> <li>Check mounting of tone ring and condition of teeth.</li> <li>Check condition and retention of ABS sensor spring clip.</li> <li>Check ABS sensor cable routing and clipping.</li> <li>Check for corroded or damaged wiring between the ECU and the ABS wheel speed sensor.</li> <li>Turn the wheel at half a revolution per second and verify 0.2 AC volt sensor output voltage.</li> </ul>
791	3	11	5 + 4	Abnormal Speed (Chatter)	ABS WL	ABS Wheel Disabled ESC/RSC/ATC/ HSA Disabled	Brake drag or chatter has been detected. Abnormal vibrations detected which affect sensor signal.	<ul style="list-style-type: none"> <li>Check for loose wheel bearings or excessive hub runout.</li> <li>Check sensor wiring and connectors for intermittent contact.</li> <li>Check mounting of tone ring and condition of teeth.</li> <li>Check condition and retention of ABS sensor spring clip as well as the mounting block.</li> <li>Check for corroded or damaged wiring between the ECU and the ABS wheel speed sensor.</li> <li>Turn the wheel at half a revolution per second and verify 0.2 AC volt sensor output voltage.</li> </ul>
791	3	12	5 + 4	Frequency Too High	ABS WL	ABS Wheel Disabled ESC/RSC/ATC/ HSA Disabled	A non-plausible sensor frequency has been measured.	<ul style="list-style-type: none"> <li>Check sensor wiring and connectors for intermittent contact.</li> <li>Check if brake at this location is operating correctly, i.e.; potentially dragging.</li> <li>Check for corroded or damaged wiring between the ECU and the ABS wheel speed sensor.</li> </ul>
789	3	13	N/A	Brake Performance issue RFLR, R3rd	ATC WL	N/A	Brake performance monitor condition exceeded.	<ul style="list-style-type: none"> <li>Check the foundation brakes for all wheel ends.</li> </ul>

4010649a

# SPN, SID, FMI Fault Codes

Fig. 9.7

SPN	SID	FMI	Blink Code	Description	Warning Light	System Reaction	Cause	Action
<b>Right Rear Wheel Speed Sensor</b>								
792	4	1	3 + 3	Air Gap	ABS WL	ABS Wheel Disabled ESC/RSC/ATC/ HSA Disabled	Sensor air gap is too large, sensor output voltage is too low but is high enough to be read by ECU.	<ul style="list-style-type: none"> <li>Adjust wheel sensor to touch tone ring.</li> <li>Check condition of ABS sensor head.</li> <li>Check for loose wheel bearings or excessive hub runout.</li> <li>Check mounting of ABS tone ring and condition of teeth.</li> <li>Check condition and retention of ABS sensor spring clip.</li> <li>Check ABS sensor cable routing and clipping.</li> <li>Turn the wheel at half a revolution per second and verify 0.2 AC volt sensor output voltage.</li> </ul>
792	4	2	5 + 3	Incorrect Tire	ABS WL	ABS Wheel Disabled ESC/RSC/ATC/ HSA Disabled	System has detected a significant difference in the proportion of tire diameter to number of tone ring teeth between wheel ends. 10% (+/-2%)	<ul style="list-style-type: none"> <li>Check for tire size mismatch.</li> <li>Check for correct number of tone ring teeth.</li> <li>Verify that ECU is programmed for the correct vehicle.</li> <li>Contact WABCO or OEM.</li> </ul>
792	4	3	4 + 3	Shorted to UBATT	ABS WL	ABS Wheel Disabled ESC/RSC/ATC/ HSA Disabled	Continuity between the sensor connection and battery voltage (short circuit) is detected.	<ul style="list-style-type: none"> <li>Verify 900-2000 ohms resistance through sensor circuit.</li> <li>Verify no DC voltage through sensor circuit Key ON.</li> <li>Check for corroded or damaged wiring between the ECU and the ABS wheel speed sensor.</li> </ul>
792	4	4	4 + 3	Shorted to Ground	ABS WL	ABS Wheel Disabled ESC/RSC/ATC/ HSA Disabled	Continuity between the sensor connection and ground (short circuit) is detected.	<ul style="list-style-type: none"> <li>Verify 900-2000 ohms resistance through sensor circuit.</li> <li>Check for continuity between the ABS sensor connection and ground.</li> <li>Check for corroded or damaged wiring between the ECU and the ABS wheel speed sensor.</li> <li>Verify wheel speed sensor wires are not switched left/right.</li> </ul>
792	4	5	4 + 3	Open Circuit	ABS WL	ABS Wheel Disabled ESC/RSC/ATC/ HSA Disabled	An open circuit has been detected, i.e. ECU detects a disconnected wheel speed sensor.	<ul style="list-style-type: none"> <li>Check sensor, sensor cable and connectors to verify no loose or damaged connection.</li> <li>Verify 900-2000 ohms resistance through sensor circuit.</li> <li>Verify wheel speed sensor wires are not switched left/right.</li> </ul>
792	4	6	4 + 3	Short Circuit	ABS WL	ABS Wheel Disabled ESC/RSC/ATC/ HSA Disabled	Continuity interruption between the sensor connections (short circuit) has been detected.	<ul style="list-style-type: none"> <li>Verify 900-2000 ohms resistance through sensor circuit.</li> <li>Check for corroded or damaged wiring between the ECU and the ABS wheel speed sensor.</li> </ul>

4010650a

# SPN, SID, FMI Fault Codes

Fig. 9.8

SPN	SID	FMI	Blink Code	Description	Warning Light	System Reaction	Cause	Action
792	4	7	6 + 3	Incorrect Tone Ring	ABS WL	ABS Wheel Disabled ESC/RSC/ATC/ HSA Disabled	Wheel speed signal drops out periodically at speeds higher than 6 mph.	<ul style="list-style-type: none"> <li>• Check for damaged or missing teeth on tone ring.</li> <li>• Verify tone ring is not corroded or with contamination.</li> </ul>
792	4	8	3 + 3	Excessive Slip	ABS WL	ABS Wheel Disabled ESC/RSC/ATC/ HSA Disabled	Wheel slip over 16 seconds continuously has been detected.	<ul style="list-style-type: none"> <li>• Adjust wheel sensor to touch tooth wheel.</li> <li>• Check sensor gap.</li> <li>• Check for loose wheel bearings or excessive hub runout.</li> </ul>
792	4	9	5 + 3	Wires Mismatched	ABS WL	ABS Wheel Disabled ESC/RSC/ATC/ HSA Disabled	A sensor lead from an incorrect wheel end has been detected.	<ul style="list-style-type: none"> <li>• Check for mismatch fault of another sensor.</li> <li>• Verify correct harness location and wiring for sensor.</li> <li>• Check for corroded or damaged wiring between the ECU and the ABS wheel speed sensor.</li> </ul>
792	4	10	3 + 3	Speed Drop-Out	ABS WL	ABS Wheel Disabled ESC/RSC/ATC/ HSA Disabled	A temporary loss of the ABS wheel speed signal has been detected.	<ul style="list-style-type: none"> <li>• Adjust wheel speed sensor until it touches the tone ring.</li> <li>• Check for loose wheel bearings or excessive hub runout.</li> <li>• Check sensor wiring and connectors for intermittent contact.</li> <li>• Check condition of ABS sensor head.</li> <li>• Check mounting of tone ring and condition of teeth.</li> <li>• Check condition and retention of ABS sensor spring clip.</li> <li>• Check ABS sensor cable routing and clipping.</li> <li>• Check for corroded or damaged wiring between the ECU and the ABS wheel speed sensor.</li> <li>• Turn the wheel at half a revolution per second and verify 0.2 AC volt sensor output voltage.</li> </ul>
792	4	11	5 + 3	Abnormal Speed (Chatter)	ABS WL	ABS Wheel Disabled ESC/RSC/ATC/ HSA Disabled	Brake drag or chatter has been detected. Abnormal vibrations detected which affect sensor signal.	<ul style="list-style-type: none"> <li>• Check for loose wheel bearings or excessive hub runout.</li> <li>• Check sensor wiring and connectors for intermittent contact.</li> <li>• Check mounting of tone ring and condition of teeth.</li> <li>• Check condition and retention of ABS sensor spring clip as well as the mounting block.</li> <li>• Check for corroded or damaged wiring between the ECU and the ABS wheel speed sensor.</li> <li>• Turn the wheel at half a revolution per second and verify 0.2 AC volt sensor output voltage.</li> </ul>
792	4	12	5 + 3	Frequency Too High	ABS WL	ABS Wheel Disabled ESC/RSC/ATC/ HSA Disabled	A non-plausible sensor frequency has been measured.	<ul style="list-style-type: none"> <li>• Check sensor wiring and connectors for intermittent contact.</li> <li>• Check if brake at this location is operating correctly, i.e.; potentially dragging.</li> <li>• Check for corroded or damaged wiring between the ECU and the ABS wheel speed sensor.</li> </ul>

4010651a

# SPN, SID, FMI Fault Codes

Fig. 9.9

SPN	SID	FMI	Blink Code	Description	Warning Light	System Reaction	Cause	Action
<b>Left Third Axle Wheel Speed Sensor</b>								
793	5	1	3 + 6	Air Gap	ABS WL	ABS Wheel Disabled ESC/RSC/ATC/ HSA Disabled	Sensor air gap is too large, sensor output voltage is too low but is high enough to be read by ECU.	<ul style="list-style-type: none"> <li>Adjust wheel sensor to touch tone ring.</li> <li>Check condition of ABS sensor head.</li> <li>Check for loose wheel bearings or excessive hub runout.</li> <li>Check mounting of ABS tone ring and condition of teeth.</li> <li>Check condition and retention of ABS sensor spring clip.</li> <li>Check ABS sensor cable routing and clipping.</li> <li>Turn the wheel at half a revolution per second and verify 0.2 AC volt sensor output voltage.</li> </ul>
793	5	2	5 + 6	Incorrect Tire	ABS WL	ABS Wheel Disabled ESC/RSC/ATC/ HSA Disabled	System has detected a significant difference in the proportion of tire diameter to number of tone ring teeth between wheel ends. 10% (+/-2%)	<ul style="list-style-type: none"> <li>Check for tire size mismatch.</li> <li>Check for correct number of tone ring teeth.</li> <li>Verify that ECU is programmed for the correct vehicle.</li> <li>Contact WABCO or OEM.</li> </ul>
793	5	3	4 + 6	Shorted to UBATT	ABS WL	ABS Wheel Disabled ESC/RSC/ATC/ HSA Disabled	Continuity between the sensor connection and battery voltage (short circuit) is detected.	<ul style="list-style-type: none"> <li>Verify 900-2000 ohms resistance through sensor circuit.</li> <li>Verify no DC voltage through sensor circuit Key ON.</li> <li>Check for corroded or damaged wiring between the ECU and the ABS wheel speed sensor.</li> </ul>
793	5	4	4 + 6	Shorted to Ground	ABS WL	ABS Wheel Disabled ESC/RSC/ATC/ HSA Disabled	Continuity between the sensor connection and ground (short circuit) is detected.	<ul style="list-style-type: none"> <li>Verify 900-2000 ohms resistance through sensor circuit.</li> <li>Check for continuity between the ABS sensor connection and ground.</li> <li>Check for corroded or damaged wiring between the ECU and the ABS wheel speed sensor.</li> <li>Verify wheel speed sensor wires are not switched left/right.</li> </ul>
793	5	5	4 + 6	Open Circuit	ABS WL	ABS Wheel Disabled ESC/RSC/ATC/ HSA Disabled	An open circuit has been detected, i.e. ECU detects a disconnected wheel speed sensor.	<ul style="list-style-type: none"> <li>Check sensor, sensor cable and connectors to verify no loose or damaged connection.</li> <li>Verify 900-2000 ohms resistance through sensor circuit.</li> <li>Verify wheel speed sensor wires are not switched left/right.</li> </ul>
793	5	6	4 + 6	Short Circuit	ABS WL	ABS Wheel Disabled ESC/RSC/ATC/ HSA Disabled	Continuity interruption between the sensor connections (short circuit) has been detected.	<ul style="list-style-type: none"> <li>Verify 900-2000 ohms resistance through sensor circuit.</li> <li>Check for corroded or damaged wiring between the ECU and the ABS wheel speed sensor.</li> </ul>

4010652a

# SPN, SID, FMI Fault Codes

Fig. 9.10

SPN	SID	FMI	Blink Code	Description	Warning Light	System Reaction	Cause	Action
793	5	7	6 + 6	Incorrect Tone Ring	ABS WL	ABS Wheel Disabled ESC/RSC/ATC/ HSA Disabled	Wheel speed signal drops out periodically at speeds higher than 6 mph.	<ul style="list-style-type: none"> <li>• Check for damaged or missing teeth on tone ring.</li> <li>• Verify tone ring is not corroded or with contamination.</li> </ul>
793	5	8	3 + 6	Excessive Slip	ABS WL	ABS Wheel Disabled ESC/RSC/ATC/ HSA Disabled	Wheel slip over 16 seconds continuously has been detected.	<ul style="list-style-type: none"> <li>• Adjust wheel sensor to touch tooth wheel.</li> <li>• Check sensor gap.</li> <li>• Check for loose wheel bearings or excessive hub runout.</li> </ul>
793	5	9	5 + 6	Wires Mismatched	ABS WL	ABS Wheel Disabled ESC/RSC/ATC/ HSA Disabled	A sensor lead from an incorrect wheel end has been detected.	<ul style="list-style-type: none"> <li>• Check for mismatch fault of another sensor.</li> <li>• Verify correct harness location and wiring for sensor.</li> <li>• Check for corroded or damaged wiring between the ECU and the ABS wheel speed sensor.</li> </ul>
793	5	10	3 + 6	Speed Drop-Out	ABS WL	ABS Wheel Disabled ESC/RSC/ATC/ HSA Disabled	A temporary loss of the ABS wheel speed signal has been detected.	<ul style="list-style-type: none"> <li>• Adjust wheel speed sensor until it touches the tone ring.</li> <li>• Check for loose wheel bearings or excessive hub runout.</li> <li>• Check sensor wiring and connectors for intermittent contact.</li> <li>• Check condition of ABS sensor head.</li> <li>• Check mounting of tone ring and condition of teeth.</li> <li>• Check condition and retention of ABS sensor spring clip.</li> <li>• Check ABS sensor cable routing and clipping.</li> <li>• Check for corroded or damaged wiring between the ECU and the ABS wheel speed sensor.</li> <li>• Turn the wheel at half a revolution per second and verify 0.2 AC volt sensor output voltage.</li> </ul>
793	5	11	5 + 6	Abnormal Speed (Chatter)	ABS WL	ABS Wheel Disabled ESC/RSC/ATC/ HSA Disabled	Brake drag or chatter has been detected. Abnormal vibrations detected which affect sensor signal.	<ul style="list-style-type: none"> <li>• Check for loose wheel bearings or excessive hub runout.</li> <li>• Check sensor wiring and connectors for intermittent contact.</li> <li>• Check mounting of tone ring and condition of teeth.</li> <li>• Check condition and retention of ABS sensor spring clip as well as the mounting block.</li> <li>• Check for corroded or damaged wiring between the ECU and the ABS wheel speed sensor.</li> <li>• Turn the wheel at half a revolution per second and verify 0.2 AC volt sensor output voltage.</li> </ul>
793	5	12	5 + 6	Frequency Too High	ABS WL	ABS Wheel Disabled ESC/RSC/ATC/ HSA Disabled	A non-plausible sensor frequency has been measured.	<ul style="list-style-type: none"> <li>• Check sensor wiring and connectors for intermittent contact.</li> <li>• Check if brake at this location is operating correctly, i.e., potentially dragging.</li> <li>• Check for corroded or damaged wiring between the ECU and the ABS wheel speed sensor.</li> </ul>

4010653a

# SPN, SID, FMI Fault Codes

Fig. 9.11

SPN	SID	FMI	Blink Code	Description	Warning Light	System Reaction	Cause	Action
<b>Right Third Axle Wheel Speed Sensor</b>								
794	6	1	3 + 5	Air Gap	ABS WL	ABS Wheel Disabled ESC/RSC/ATC/ HSA Disabled	Sensor air gap is too large, sensor output voltage is too low but is high enough to be read by ECU.	<ul style="list-style-type: none"> <li>Adjust wheel sensor to touch tone ring.</li> <li>Check condition of ABS sensor head.</li> <li>Check for loose wheel bearings or excessive hub runout.</li> <li>Check mounting of ABS tone ring and condition of teeth.</li> <li>Check condition and retention of ABS sensor spring clip.</li> <li>Check ABS sensor cable routing and clipping.</li> <li>Turn the wheel at half a revolution per second and verify 0.2 AC volt sensor output voltage.</li> </ul>
794	6	2	5 + 5	Incorrect Tire	ABS WL	ABS Wheel Disabled ESC/RSC/ATC/ HSA Disabled	System has detected a significant difference in the proportion of tire diameter to number of tone ring teeth between wheel ends. 10% (+/-2%)	<ul style="list-style-type: none"> <li>Check for tire size mismatch.</li> <li>Check for correct number of tone ring teeth.</li> <li>Verify that ECU is programmed for the correct vehicle.</li> <li>Contact WABCO or OEM.</li> </ul>
794	6	3	4 + 5	Shorted to UBATT	ABS WL	ABS Wheel Disabled ESC/RSC/ATC/ HSA Disabled	Continuity between the sensor connection and battery voltage (short circuit) is detected.	<ul style="list-style-type: none"> <li>Verify 900-2000 ohms resistance through sensor circuit.</li> <li>Verify no DC voltage through sensor circuit Key ON.</li> <li>Check for corroded or damaged wiring between the ECU and the ABS wheel speed sensor.</li> </ul>
794	6	4	4 + 5	Shorted to Ground	ABS WL	ABS Wheel Disabled ESC/RSC/ATC/ HSA Disabled	Continuity between the sensor connection and ground (short circuit) is detected.	<ul style="list-style-type: none"> <li>Verify 900-2000 ohms resistance through sensor circuit.</li> <li>Check for continuity between the ABS sensor connection and ground.</li> <li>Check for corroded or damaged wiring between the ECU and the ABS wheel speed sensor.</li> <li>Verify wheel speed sensor wires are not switched left/right.</li> </ul>
794	6	5	4 + 5	Open Circuit	ABS WL	ABS Wheel Disabled ESC/RSC/ATC/ HSA Disabled	An open circuit has been detected, i.e. ECU detects a disconnected wheel speed sensor.	<ul style="list-style-type: none"> <li>Check sensor, sensor cable and connectors to verify no loose or damaged connection.</li> <li>Verify 900-2000 ohms resistance through sensor circuit.</li> <li>Verify wheel speed sensor wires are not switched left/right.</li> </ul>
794	6	6	4 + 5	Short Circuit	ABS WL	ABS Wheel Disabled ESC/RSC/ATC/ HSA Disabled	Continuity interruption between the sensor connections (short circuit) has been detected.	<ul style="list-style-type: none"> <li>Verify 900-2000 ohms resistance through sensor circuit.</li> <li>Check for corroded or damaged wiring between the ECU and the ABS wheel speed sensor.</li> </ul>

4010654a

# SPN, SID, FMI Fault Codes

Fig. 9.12

SPN	SID	FMI	Blink Code	Description	Warning Light	System Reaction	Cause	Action
794	6	7	6 + 5	Incorrect Tone Ring	ABS WL	ABS Wheel Disabled ESC/RSC/ATC/ HSA Disabled	Wheel speed signal drops out periodically at speeds higher than 6 mph.	<ul style="list-style-type: none"> <li>• Check for damaged or missing teeth on tone ring.</li> <li>• Verify tone ring is not corroded or with contamination.</li> </ul>
794	6	8	3 + 5	Excessive Slip	ABS WL	ABS Wheel Disabled ESC/RSC/ATC/ HSA Disabled	Wheel slip over 16 seconds continuously has been detected.	<ul style="list-style-type: none"> <li>• Adjust wheel sensor to touch tooth wheel.</li> <li>• Check sensor gap.</li> <li>• Check for loose wheel bearings or excessive hub runout.</li> </ul>
794	6	9	5 + 5	Wires Mismatched	ABS WL	ABS Wheel Disabled ESC/RSC/ATC/ HSA Disabled	A sensor lead from an incorrect wheel end has been detected.	<ul style="list-style-type: none"> <li>• Check for mismatch fault of another sensor.</li> <li>• Verify correct harness location and wiring for sensor.</li> <li>• Check for corroded or damaged wiring between the ECU and the ABS wheel speed sensor.</li> </ul>
794	6	10	3 + 5	Speed Drop-Out	ABS WL	ABS Wheel Disabled ESC/RSC/ATC/ HSA Disabled	A temporary loss of the ABS wheel speed signal has been detected.	<ul style="list-style-type: none"> <li>• Adjust wheel speed sensor until it touches the tone ring.</li> <li>• Check for loose wheel bearings or excessive hub runout.</li> <li>• Check sensor wiring and connectors for intermittent contact.</li> <li>• Check condition of ABS sensor head.</li> <li>• Check mounting of tone ring and condition of teeth.</li> <li>• Check condition and retention of ABS sensor spring clip.</li> <li>• Check ABS sensor cable routing and clipping.</li> <li>• Check for corroded or damaged wiring between the ECU and the ABS wheel speed sensor.</li> <li>• Turn the wheel at half a revolution per second and verify 0.2 AC volt sensor output voltage.</li> </ul>
794	6	11	5 + 5	Abnormal Speed (Chatter)	ABS WL	ABS Wheel Disabled ESC/RSC/ATC/ HSA Disabled	Brake drag or chatter has been detected. Abnormal vibrations detected which affect sensor signal.	<ul style="list-style-type: none"> <li>• Check for loose wheel bearings or excessive hub runout.</li> <li>• Check sensor wiring and connectors for intermittent contact.</li> <li>• Check mounting of tone ring and condition of teeth.</li> <li>• Check condition and retention of ABS sensor spring clip as well as the mounting block.</li> <li>• Check for corroded or damaged wiring between the ECU and the ABS wheel speed sensor.</li> <li>• Turn the wheel at half a revolution per second and verify 0.2 AC volt sensor output voltage.</li> </ul>
794	6	12	5 + 5	Frequency Too High	ABS WL	ABS Wheel Disabled ESC/RSC/ATC/ HSA Disabled	A non-plausible sensor frequency has been measured.	<ul style="list-style-type: none"> <li>• Check sensor wiring and connectors for intermittent contact.</li> <li>• Check if brake at this location is operating correctly, i.e.; potentially dragging.</li> <li>• Check for corroded or damaged wiring between the ECU and the ABS wheel speed sensor.</li> </ul>

4010655a



# SPN, SID, FMI Fault Codes

Fig. 9.13

SPN	SID	FMI	Blink Code	Description	Warning Light	System Reaction	Cause	Action
<b>Left Front Modulator Valve</b>								
795	7	3	2 + 2	Shorted to UBATT	ABS WL	ABS Wheel Disabled ESC/RSC/ATC/ HSA Disabled	Continuity between Inlet (IV) or Outlet (OV) and battery voltage or another modulator wire (short circuit) is detected.	<ul style="list-style-type: none"> <li>Verify valve resistance of 4.0-9.0 ohm between IV to ground and OV to ground for 12v system (11.0-21.0 ohms for 24v system).</li> <li>Verify resistance through harness and valve together is the same as valve by itself.</li> <li>Verify no voltage between Inlet/Outlet circuit and ground at the valve.</li> <li>Verify no voltage through the harness with ECU unplugged and Key ON.</li> <li>Check for corroded or damaged wiring between the ECU and the modulator valve.</li> </ul>
795	7	5	2 + 2	Open Circuit	ABS WL	ABS Wheel Disabled ESC/RSC/ATC/ HSA Disabled	ECU has detected that Inlet (IV), Outlet (OV) or both are not connected.	<ul style="list-style-type: none"> <li>Verify valve resistance of 4.0-9.0 ohm between IV to ground and OV to ground for 12v system (11.0-21.0 ohms for 24v system).</li> <li>Verify resistance through harness and valve together is the same as valve by itself.</li> <li>Check if connectors are fully seated and verify no open connections.</li> <li>Check for corroded or damaged wiring between the ECU and the modulator valve.</li> </ul>
795	7	6	2 + 2	Shorted to Ground	ABS WL	ABS Wheel Disabled ESC/RSC/ATC/ HSA Disabled	Continuity between Inlet (IV) or Outlet (OV) and ground (short circuit) is detected.	<ul style="list-style-type: none"> <li>Verify valve resistance of 4.0-9.0 ohm between IV to ground and OV to ground for 12v system (11.0-21.0 ohms for 24v system).</li> <li>Verify resistance through harness and valve together is the same as valve by itself.</li> <li>Verify resistance through harness and valve together is the same as valve by itself.</li> <li>Check for corroded or damaged wiring between the ECU and the modulator valve.</li> </ul>
<b>Right Front Modulator Valve</b>								
796	8	3	2 + 1	Shorted to UBATT	ABS WL	ABS Wheel Disabled ESC/RSC/ATC/ HSA Disabled	Continuity between Inlet (IV) or Outlet (OV) and battery voltage or another modulator wire (short circuit) is detected.	<ul style="list-style-type: none"> <li>Verify valve resistance of 4.0-9.0 ohm between IV to ground and OV to ground for 12v system (11.0-21.0 ohms for 24v system).</li> <li>Verify resistance through harness and valve together is the same as valve by itself.</li> <li>Verify no voltage between Inlet/Outlet circuit and ground at the valve.</li> <li>Verify no voltage through the harness with ECU unplugged and Key ON.</li> <li>Check for corroded or damaged wiring between the ECU and the modulator valve.</li> </ul>
796	8	5	2 + 1	Open Circuit	ABS WL	ABS Wheel Disabled ESC/RSC/ATC/ HSA Disabled	ECU has detected that Inlet (IV), Outlet (OV) or both are not connected.	<ul style="list-style-type: none"> <li>Verify valve resistance of 4.0-9.0 ohm between IV to ground and OV to ground for 12v system (11.0-21.0 ohms for 24v system).</li> <li>Verify resistance through harness and valve together is the same as valve by itself.</li> <li>Check if connectors are fully seated and verify no open connections.</li> <li>Check for corroded or damaged wiring between the ECU and the modulator valve.</li> </ul>
796	8	6	2 + 1	Shorted to Ground	ABS WL	ABS Wheel Disabled ESC/RSC/ATC/ HSA Disabled	Continuity between Inlet (IV) or Outlet (OV) and ground (short circuit) is detected.	<ul style="list-style-type: none"> <li>Verify valve resistance of 4.0-9.0 ohm between IV to ground and OV to ground for 12v system (11.0-21.0 ohms for 24v system).</li> <li>Verify resistance through harness and valve together is the same as valve by itself.</li> <li>Verify resistance through harness and valve together is the same as valve by itself.</li> <li>Check for corroded or damaged wiring between the ECU and the modulator valve.</li> </ul>

4010656a

# SPN, SID, FMI Fault Codes

Fig. 9.14

SPN	SID	FMI	Blink Code	Description	Warning Light	System Reaction	Cause	Action
<b>Left Rear Modulator Valve</b>								
797	9	3	2 + 4	Shorted to UBATT	ABS WL	ABS Wheel Disabled ESC/RSC/ATC/ HSA Disabled	Continuity between Inlet (IV) or Outlet (OV) and battery voltage or another modulator wire (short circuit) is detected.	<ul style="list-style-type: none"> <li>Verify valve resistance of 4.0-9.0 ohm between IV to ground and OV to ground for 12v system (11.0-21.0 ohms for 24v system).</li> <li>Verify resistance through harness and valve together is the same as valve by itself.</li> <li>Verify no voltage between Inlet/Outlet circuit and ground at the valve.</li> <li>Verify no voltage through the harness with ECU unplugged and Key ON.</li> <li>Check for corroded or damaged wiring between the ECU and the modulator valve.</li> </ul>
797	9	5	2 + 4	Open Circuit	ABS WL	ABS Wheel Disabled ESC/RSC/ATC/ HSA Disabled	ECU has detected that Inlet (IV), Outlet (OV) or both are not connected.	<ul style="list-style-type: none"> <li>Verify valve resistance of 4.0-9.0 ohm between IV to ground and OV to ground for 12v system (11.0-21.0 ohms for 24v system).</li> <li>Verify resistance through harness and valve together is the same as valve by itself.</li> <li>Check if connectors are fully seated and verify no open connections.</li> <li>Check for corroded or damaged wiring between the ECU and the modulator valve.</li> </ul>
797	9	6	2 + 4	Shorted to Ground	ABS WL	ABS Wheel Disabled ESC/RSC/ATC/ HSA Disabled	Continuity between Inlet (IV) or Outlet (OV) and ground (short circuit) is detected.	<ul style="list-style-type: none"> <li>Verify valve resistance of 4.0-9.0 ohm between IV to ground and OV to ground for 12v system (11.0-21.0 ohms for 24v system).</li> <li>Verify resistance through harness and valve together is the same as valve by itself.</li> <li>Verify resistance through harness and valve together is the same as valve by itself.</li> <li>Check for corroded or damaged wiring between the ECU and the modulator valve.</li> </ul>
<b>Right Rear Modulator Valve</b>								
798	10	3	2 + 3	Shorted to UBATT	ABS WL	ABS Wheel Disabled ESC/RSC/ATC/ HSA Disabled	Continuity between Inlet (IV) or Outlet (OV) and battery voltage or another modulator wire (short circuit) is detected.	<ul style="list-style-type: none"> <li>Verify valve resistance of 4.0-9.0 ohm between IV to ground and OV to ground for 12v system (11.0-21.0 ohms for 24v system).</li> <li>Verify resistance through harness and valve together is the same as valve by itself.</li> <li>Verify no voltage between Inlet/Outlet circuit and ground at the valve.</li> <li>Verify no voltage through the harness with ECU unplugged and Key ON.</li> <li>Check for corroded or damaged wiring between the ECU and the modulator valve.</li> </ul>
798	10	5	2 + 3	Open Circuit	ABS WL	ABS Wheel Disabled ESC/RSC/ATC/ HSA Disabled	ECU has detected that Inlet (IV), Outlet (OV) or both are not connected.	<ul style="list-style-type: none"> <li>Verify valve resistance of 4.0-9.0 ohm between IV to ground and OV to ground for 12v system (11.0-21.0 ohms for 24v system).</li> <li>Verify resistance through harness and valve together is the same as valve by itself.</li> <li>Check if connectors are fully seated and verify no open connections.</li> <li>Check for corroded or damaged wiring between the ECU and the modulator valve.</li> </ul>
798	10	6	2 + 3	Shorted to Ground	ABS WL	ABS Wheel Disabled ESC/RSC/ATC/ HSA Disabled	Continuity between Inlet (IV) or Outlet (OV) and ground (short circuit) is detected.	<ul style="list-style-type: none"> <li>Verify valve resistance of 4.0-9.0 ohm between IV to ground and OV to ground for 12v system (11.0-21.0 ohms for 24v system).</li> <li>Verify resistance through harness and valve together is the same as valve by itself.</li> <li>Verify resistance through harness and valve together is the same as valve by itself.</li> <li>Check for corroded or damaged wiring between the ECU and the modulator valve.</li> </ul>

4010657a

# SPN, SID, FMI Fault Codes

Fig. 9.15

SPN	SID	FMI	Blink Code	Description	Warning Light	System Reaction	Cause	Action
<b>Left Third Axle Modulator Valve</b>								
799	11	3	2 + 6	Shorted to UBATT	ABS WL	ABS Wheel Disabled ESC/RSC/ATC/ HSA Disabled	Continuity between Inlet (IV) or Outlet (OV) and battery voltage or another modulator wire (short circuit) is detected.	<ul style="list-style-type: none"> <li>Verify valve resistance of 4.0-9.0 ohm between IV to ground and OV to ground for 12v system (11.0-21.0 ohms for 24v system).</li> <li>Verify resistance through harness and valve together is the same as valve by itself.</li> <li>Verify no voltage between Inlet/Outlet circuit and ground at the valve.</li> <li>Verify no voltage through the harness with ECU unplugged and Key ON.</li> <li>Check for corroded or damaged wiring between the ECU and the modulator valve.</li> </ul>
799	11	5	2 + 6	Open Circuit	ABS WL	ABS Wheel Disabled ESC/RSC/ATC/ HSA Disabled	ECU has detected that Inlet (IV), Outlet (OV) or both are not connected.	<ul style="list-style-type: none"> <li>Verify valve resistance of 4.0-9.0 ohm between IV to ground and OV to ground for 12v system (11.0-21.0 ohms for 24v system).</li> <li>Verify resistance through harness and valve together is the same as valve by itself.</li> <li>Check if connectors are fully seated and verify no open connections.</li> <li>Check for corroded or damaged wiring between the ECU and the modulator valve.</li> </ul>
799	11	6	2 + 6	Shorted to Ground	ABS WL	ABS Wheel Disabled ESC/RSC/ATC/ HSA Disabled	Continuity between Inlet (IV) or Outlet (OV) and ground (short circuit) is detected.	<ul style="list-style-type: none"> <li>Verify valve resistance of 4.0-9.0 ohm between IV to ground and OV to ground for 12v system (11.0-21.0 ohms for 24v system).</li> <li>Verify resistance through harness and valve together is the same as valve by itself.</li> <li>Verify resistance through harness and valve together is the same as valve by itself.</li> <li>Check for corroded or damaged wiring between the ECU and the modulator valve.</li> </ul>
<b>Right Third Axle Modulator Valve</b>								
800	12	3	2 + 5	Shorted to UBATT	ABS WL	ABS Wheel Disabled ESC/RSC/ATC/ HSA Disabled	Continuity between Inlet (IV) or Outlet (OV) and battery voltage or another modulator wire (short circuit) is detected.	<ul style="list-style-type: none"> <li>Verify valve resistance of 4.0-9.0 ohm between IV to ground and OV to ground for 12v system (11.0-21.0 ohms for 24v system).</li> <li>Verify resistance through harness and valve together is the same as valve by itself.</li> <li>Verify no voltage between Inlet/Outlet circuit and ground at the valve.</li> <li>Verify no voltage through the harness with ECU unplugged and Key ON.</li> <li>Check for corroded or damaged wiring between the ECU and the modulator valve.</li> </ul>
800	12	5	2 + 5	Open Circuit	ABS WL	ABS Wheel Disabled ESC/RSC/ATC/ HSA Disabled	ECU has detected that Inlet (IV), Outlet (OV) or both are not connected.	<ul style="list-style-type: none"> <li>Verify valve resistance of 4.0-9.0 ohm between IV to ground and OV to ground for 12v system (11.0-21.0 ohms for 24v system).</li> <li>Verify resistance through harness and valve together is the same as valve by itself.</li> <li>Check if connectors are fully seated and verify no open connections.</li> <li>Check for corroded or damaged wiring between the ECU and the modulator valve.</li> </ul>
800	12	6	2 + 5	Shorted to Ground	ABS WL	ABS Wheel Disabled ESC/RSC/ATC/ HSA Disabled	Continuity between Inlet (IV) or Outlet (OV) and ground (short circuit) is detected.	<ul style="list-style-type: none"> <li>Verify valve resistance of 4.0-9.0 ohm between IV to ground and OV to ground for 12v system (11.0-21.0 ohms for 24v system).</li> <li>Verify resistance through harness and valve together is the same as valve by itself.</li> <li>Verify resistance through harness and valve together is the same as valve by itself.</li> <li>Check for corroded or damaged wiring between the ECU and the modulator valve.</li> </ul>

4010658a

Fig. 9.16

SPN	SID	FMI	Blink Code	Description	Warning Light	System Reaction	Cause	Action
<b>Engine Retarder Relay, Automatic Third Brake Application Relay</b>								
801	13	3	7 + 3	Shorted to UBATT	ABS WL	Hardwired Retarder Control is Disabled	Continuity between the retarder relay output and the battery voltage has been detected.	<ul style="list-style-type: none"> <li>Check for continuity between the retarder relay output and voltage supply.</li> <li>Check for corroded or damaged wiring between the ECU and the relay.</li> <li>Verify if vehicle is equipped with an engine retarder relay or a third brake relay such as driveline brake, exhaust brake or engine brake. If hardwired retarder control is not installed on the vehicle but this fault is present, the operator should perform "Reset Memorized Components" TOOLBOX™ Software procedure.</li> <li>Verify with the OEM if connector X1 pin 14 Cab ECU or connector X1 pin 5 Frame ECU) circuit is used on the vehicle, circuit has many possible uses other than a retarder, prior to performing a "Reset Memorized" or "Reconfiguring" the ECU.</li> </ul>
801	13	5	7 + 3	Open Circuit	ABS WL	Hardwired Retarder Control is Disabled	ECU has detected that the retarder relay is not connected but was previously learned.	<ul style="list-style-type: none"> <li>Check for broken wires or connectors and verify all connections are fully seated, relay present and operational.</li> <li>Check for corroded or damaged wiring between the ECU and the relay.</li> <li>Verify if vehicle is equipped with an engine retarder relay or a third brake relay such as driveline brake, exhaust brake or engine brake. If hardwired retarder control is not installed on the vehicle but this fault is present, the operator should perform "Reset Memorized Components" through TOOLBOX™ Software procedure.</li> <li>Verify with the OEM if connector X1 pin 14 Cab ECU or connector X1 pin 5 Frame ECU) circuit is used on the vehicle, circuit has many possible uses other than a retarder, prior to performing a "Reset Memorized" or "Reconfiguring" the ECU.</li> </ul>
801	13	6	7 + 3	Shorted to Ground	ABS WL	Hardwired Retarder Control is Disabled	Continuity between the retarder relay output and ground has been detected.	<ul style="list-style-type: none"> <li>Check for continuity between the retarder relay output and ground.</li> <li>Check for corroded or damaged wiring between the ECU and the relay.</li> <li>Verify if vehicle is equipped with an engine retarder relay or a third brake relay such as driveline brake, exhaust brake or engine brake. If hardwired retarder control is not installed on the vehicle but this fault is present, the operator should perform "Reset Memorized Components" through TOOLBOX™ Software procedure.</li> <li>Verify with the OEM if connector X1 pin 14 Cab ECU or connector X1 pin 5 Frame ECU) circuit is used on the vehicle, circuit has many possible uses other than a retarder, prior to performing a "Reset Memorized" or "Reconfiguring" the ECU.</li> </ul>
<b>Other Components</b>								
701		3		Shorted to UBATT	HSA WL	HSA Disabled	AUX1-Output, shorted to UB detection.	<ul style="list-style-type: none"> <li>A short circuit to UB of the AUX1-Output line was detected.</li> <li>- HISA function: The AUX1-Output used in HISA functionality. The AUX1-line is set with the HISA lamp.</li> </ul>
701		4		Shorted to Ground	HSA WL	HSA Disabled	AUX1-Output, shorted to GND detection.	<ul style="list-style-type: none"> <li>A short circuit to GND of the AUX1-Output line was detected.</li> <li>- HISA function: The AUX1-Output used for HISA functionality. The AUX1-line is set with the HISA lamp.</li> </ul>
701		5		Open Circuit	HSA WL	HSA Disabled	AUX1-Output, open circuit detection.	<ul style="list-style-type: none"> <li>An interruption of the AUX1-Output line was detected.</li> <li>- HISA function: The AUX1-Output used in HISA functionality. The AUX1-line is set with the HISA lamp.</li> </ul>
702		3		Shorted to UBATT	HSA WL	HSA Disabled	AUX2-Output, shorted to UB detection.	<ul style="list-style-type: none"> <li>A short circuit to UB of the AUX2-Output line was detected.</li> <li>- HISA function: The AUX2-Output could be used for HISA functionality. The AUX2-line is set with the HISA switch.</li> </ul>
702		4		Shorted to Ground	HSA WL	HSA Disabled	AUX2-Output, shorted to GND detection.	<ul style="list-style-type: none"> <li>A short circuit to GND of the AUX2-Output line was detected.</li> <li>- HISA function: The AUX2-Output could be used for HISA functionality. The AUX2-line is set with the HISA switch.</li> </ul>
702		5		Open Circuit	HSA WL	HSA Disabled	AUX2-Output, open circuit detection.	<ul style="list-style-type: none"> <li>An interruption of the AUX2-Output line was detected.</li> <li>- HISA function: The AUX2-Output could be used for HISA functionality. The AUX2-line is set with the HISA switch.</li> </ul>

4010659a

# SPN, SID, FMI Fault Codes

Fig. 9.17

SPN	SID	FMI	Blink Code	Description	Warning Light	System Reaction	Cause	Action
705		3		Shorted to UBATT	ATC WL	EAP Disabled	AUX5-Output, shorted to UB detection.	<ul style="list-style-type: none"> <li>An interruption of the AUX5 Output line was detected.</li> <li>Electronic air processing (EAP) function: The AUX5-output could be used for EAP functionality. See EAP maintenance manual MM-1696 for further instructions.</li> </ul>
705		4		Shorted to Ground	ATC WL	EAP Disabled	AUX5-Output, shorted to GND detection.	<ul style="list-style-type: none"> <li>An interruption of the AUX5 Output line was detected.</li> <li>Electronic air processing (EAP) function: The AUX5-output could be used for EAP functionality. See EAP maintenance manual MM-1696 for further instructions.</li> </ul>
705		5		Open Circuit	ATC WL	EAP Disabled	AUX5-Output, open circuit detection.	<ul style="list-style-type: none"> <li>An interruption of the AUX5 Output line was detected.</li> <li>Electronic air processing (EAP) function: The AUX5-output could be used for EAP functionality. See EAP maintenance manual MM-1696 for further instructions.</li> </ul>
706		3		Shorted to UBATT	ATC WL	EAP Disabled	AUX6-Output, shorted to UB detection.	<ul style="list-style-type: none"> <li>An interruption of the AUX6 Output line was detected.</li> <li>Electronic air processing (EAP) function: The AUX6-output could be used for EAP functionality. See EAP maintenance manual MM-1696 for further instructions.</li> </ul>
706		4		Shorted to Ground	ATC WL	EAP Disabled	AUX6-Output, shorted to GND detection.	<ul style="list-style-type: none"> <li>An interruption of the AUX6 Output line was detected.</li> <li>Electronic air processing (EAP) function: The AUX6-output could be used for EAP functionality. See EAP maintenance manual MM-1696 for further instructions.</li> </ul>
706		5		Open Circuit	ATC WL	EAP Disabled	AUX6-Output, open circuit detection.	<ul style="list-style-type: none"> <li>An interruption of the AUX6 Output line was detected.</li> <li>Electronic air processing (EAP) function: The AUX6-output could be used for EAP functionality. See EAP maintenance manual MM-1696 for further instructions.</li> </ul>
802	14	4	8 + 1	Supply Voltage is too Low	ABS WL (while supply voltage is detected as too low)	ABS Wheel Disabled ESC/RSC/ATC/ HSA Disabled	The supply voltage is temporarily too low.	<ul style="list-style-type: none"> <li>Measure the battery or ignition voltage under load. Verify voltage does not drop below 9v (12v system) or 18v (24v system).</li> <li>Verify correct ECU and battery ground (less than 1 ohm)</li> <li>Check the vehicle battery and associated components (alternator).</li> <li>Check for corroded or damaged wiring between the ECU and voltage supply as well as ground path.</li> <li>Check conditions of fuses.</li> </ul>
802	14	5	8 + 5	ECU Central Ground Open Circuit	ABS WL	ABS Wheel Disabled ESC/RSC/ATC/ HSA Disabled	The ECUs connection to central ground has been interrupted or the resistance measured is too high.	<ul style="list-style-type: none"> <li>Verify correct ECU central ground (less than 1 ohm resistance).</li> <li>Check for corroded, loose or damaged wiring between the ECU and central ground path.</li> </ul>
802	14	7	8 + 3	Internal Voltage Supply	ABS WL	ABS Wheel Disabled ESC/RSC/ATC/ HSA Disabled	A failure was detected on the internal ECU relay 1.	<ul style="list-style-type: none"> <li>Measure the battery or ignition voltage supply. Verify voltage is between 9v-16v (12v system) or 18v-32v (24v system).</li> <li>Verify correct ECU and battery ground (less than 1 ohm)</li> <li>Check for corroded or damaged wiring between the ECU and voltage supply as well as ground path.</li> <li>If all wiring checks are within specs and if fault repeats and does not clear, this may indicate the ECU has failed.</li> </ul>
803	15	3	8 + 5	All ABVs Output Shorted to UBATT	ABS WL	ESC/RSC/ATC Disabled	Continuity between suspect Active Braking Valve output and voltage supply (short circuit) is detected.	<ul style="list-style-type: none"> <li>Verify 7.0-14.0 ohm between ABV supply and ABV common for 12V system (26.3-49.0 ohm for 24V system).</li> <li>Check for continuity between suspect ABV ground circuit and voltage supply.</li> <li>Check for corroded or damaged wiring between the ECU and ABV.</li> <li>Fault may indicate an issue with the BPS in certain vintage ECUs. See SID 55 FMI 3.</li> </ul>

4010660a

# SPN, SID, FMI Fault Codes

Fig. 9.18

SPN	SID	FMI	Blink Code	Description	Warning Light	System Reaction	Cause	Action
803	15	4	8 + 1	ECU Voltage is Too Low	ABS WL (while supply voltage is detected as too low)	ABS Wheel Disabled ESC/RSC/ATC/ HSA Disabled	The supply voltage is temporarily too low.	<ul style="list-style-type: none"> <li>Measure the battery or ignition voltage under load. Verify voltage does not drop below 9v (12v system) or 18v (24v system).</li> <li>Verify correct ECU and battery ground (less than 1 ohm).</li> <li>Load Test between ECU powers and grounds.</li> <li>Check the vehicle battery and associated components (alternator).</li> <li>Check for corroded or damaged wiring between the ECU and voltage supply as well as ground path.</li> <li>Check conditions of fuses.</li> </ul>
803	15	5	8 + 5	All ABV's High Impedance	ABS WL	ESC/RSC/ATC/ HSA Disabled	ECU has detected that the suspect Active Braking Valve circuit is not detected, has high impedance or the circuit has been interrupted.	<ul style="list-style-type: none"> <li>Verify 7.0-14.0 ohm between ABV supply and ABV common for 12V system (26.3-49.0 ohm for 24V system).</li> <li>Verify if connectors are fully seated, check for corroded or damaged wiring between the ECU and ABVs.</li> <li>Replace ECU if all wiring checks are within spec and if fault repeats and does not clear.</li> <li>Fault may indicate an issue with the BPS in certain vintage ECUs, See SID 55 FMI 5.</li> </ul>
803	15	6	8 + 5	All ABV's Shorted to Ground	ABS WL	N/A	Continuity between suspect Active Braking Valve circuit and ground is detected.	<ul style="list-style-type: none"> <li>Verify 7.0-14.0 ohm between ABV supply and ABV common for 12V system (26.3-49.0 ohm for 24V system).</li> <li>Check for continuity between suspect Active Braking Valve circuit and ground.</li> <li>Check for corroded or damaged wiring between the ECU and ABVs.</li> <li>Check ECU grounds should be less than 1 ohm of resistance to ground.</li> <li>Replace ECU if all wiring checks are within spec and if fault repeats and does not clear.</li> </ul>
803	15	7	8 + 3	Internal Voltage Supply	ABS WL	ABS Wheel Disabled ESC/RSC/ATC/ HSA Disabled	A failure was detected on the internal ECU relay 2.	<ul style="list-style-type: none"> <li>Measure the battery or ignition voltage supply. Verify voltage is between 9v-16v (12v system) or 18v-32v (24v system).</li> <li>Verify correct ECU and battery ground (less than 1 ohm).</li> <li>Load test between ECU powers and ground.</li> <li>Check for corroded or damaged wiring between the ECU and voltage supply as well as ground path.</li> <li>If all wiring checks are within specs and if fault repeats and does not clear, this may indicate the ECU has failed.</li> </ul>
1045	16	3	7 + 7	E401 and E404 Version Only, Pressure Sensor Shorted to UBATT	ABS WL	ESC/RSC/ATC/ HSA Disabled	Continuity between pressure sensor circuit and voltage supply (short circuit) is detected. E401 and E404 version only.	<ul style="list-style-type: none"> <li>Check for continuity between pressure sensor signal circuit and voltage supply.</li> <li>Check connectors and pressure sensor for corrosion.</li> <li>It could also be possible that the ECU has detected a permanent braking signal from the pressure sensor between zero to 30 mph.</li> <li>Fault only for E401 and E404 versions only.</li> </ul>
1045	16	5	7 + 7	E401 and E404 Version Only, Pressure Sensor Shorted to Ground	ABS WL	ESC/RSC/ATC/ HSA Disabled	Continuity between pressure signal circuit and ground (short circuit) or an open circuit is detected. E401 and E404 version only.	<ul style="list-style-type: none"> <li>Verify if connectors are fully seated, check for corroded or damaged wiring between the ECU and component.</li> <li>Check for continuity between pressure sensor signal circuit and ground.</li> <li>The pressure sensor supply line could be also clogged or frozen up.</li> <li>Fault only for E401 and E404 versions only.</li> </ul>
806	18	3	7 + 2	ABV Drive Axle, Shorted to UBATT	ABS WL	ABS Wheel Disabled ESC/RSC/ATC/ HSA Disabled	Continuity between suspect Active Braking Valve circuit and voltage supply (short circuit) is detected.	<ul style="list-style-type: none"> <li>Verify 7.0-14.0 ohm between ABV supply and ABV common for 12V system (26.3-49.0 ohm for 24V system).</li> <li>Check for continuity between suspect ABV ground circuit and voltage supply.</li> <li>Check for corroded or damaged wiring between the ECU and ABV.</li> </ul>

4010661a

# SPN, SID, FMI Fault Codes

Fig. 9.19

SPN	SID	FMI	Blink Code	Description	Warning Light	System Reaction	Cause	Action
806		4		ABV Drive Axle, Shorted to ground	ABS WL	ESC/RSC/ATC/ HSA Disabled	Continuity between suspect Active Braking Valve circuit and ground is detected.	<ul style="list-style-type: none"> <li>E8 Version only.                             <ul style="list-style-type: none"> <li>Verify 7.0-14.0 ohm between ABV supply and ABV common for 12V system (26.3-49.0 ohm for 24V system).</li> </ul> </li> <li>Check for continuity between suspect Active Braking Valve circuit and ground.</li> <li>Check for corroded or damaged wiring between the ECU and ABVs.</li> </ul>
806	18	5	7 + 2	ABV Drive Axle, Open Circuit	ABS WL	ESC/RSC/ATC/ HSA Disabled	ECU has detected that the suspect Active Braking Valve circuit is not detected or the circuit has been interrupted.	<ul style="list-style-type: none"> <li>Verify 7.0-14.0 ohm between ABV supply and ABV common for 12V system (26.3-49.0 ohm for 24V system).</li> <li>Verify if connectors are fully seated, check for corroded or damaged wiring between the ECU and ABV.</li> </ul>
806	18	6	7 + 2	ABV Drive Axle, Shorted to Ground	ABS WL	ESC/RSC/ATC/ HSA Disabled	Continuity between suspect Active Braking Valve circuit and ground is detected.	<ul style="list-style-type: none"> <li>Verify 7.0-14.0 ohm between ABV supply and ABV common for 12V system (26.3-49.0 ohm for 24V system).</li> <li>Check for continuity between suspect Active Braking Valve circuit and ground.</li> <li>Check for corroded or damaged wiring between the ECU and ABVs.</li> </ul>
807	19	1	7 + 6	ABV Front Axle, Shorted to UBATT	ABS WL	ESC/RSC/ATC/ HSA Disabled	Continuity between suspect Active Braking Valve circuit and voltage supply (short circuit) is detected.	<ul style="list-style-type: none"> <li>Verify 7.0-14.0 ohm between ABV supply and ABV common for 12V system (26.3-49.0 ohm for 24V system).</li> <li>Check for continuity between suspect ABV ground circuit and voltage supply.</li> <li>Check for corroded or damaged wiring between the ECU and ABV.</li> </ul>
807	19	2	7 + 6	ABV Front Axle, Open Circuit	ABS WL	ESC/RSC/ATC/ HSA Disabled	ECU has detected that the suspect Active Braking Valve circuit is not detected or the circuit has been interrupted.	<ul style="list-style-type: none"> <li>Verify 7.0-14.0 ohm between ABV supply and ABV common for 12V system (26.3-49.0 ohm for 24V system).</li> <li>Verify if connectors are fully seated, check for corroded or damaged wiring between the ECU and ABV.</li> <li>May also indicate incorrect ECU for type of transmission.</li> </ul>
807	19	3	7 + 6	ABV Trailer Control, Shorted to UBATT	ABS WL	ESC/RSC/ATC Disabled	Continuity between suspect Active Braking Valve circuit and voltage supply (short circuit) is detected.	<ul style="list-style-type: none"> <li>Verify 7.0-14.0 ohm between ABV supply and ABV common for 12V system (26.3-49.0 ohm for 24V system).</li> <li>Check for continuity between suspect ABV ground circuit and voltage supply.</li> <li>Check for corroded or damaged wiring between the ECU and ABV.</li> </ul>
807	19	4	7 + 6	ABV Front Axle, Shorted to Ground	ABS WL	ESC/RSC/ATC/ HSA Disabled	Continuity between suspect Active Braking Valve circuit and ground is detected.	<ul style="list-style-type: none"> <li>Verify 7.0-14.0 ohm between ABV supply and ABV common for 12V system (26.3-49.0 ohm for 24V system).</li> <li>Check for continuity between suspect Active Braking Valve circuit and ground.</li> <li>Check for corroded or damaged wiring between the ECU and ABV.</li> </ul>
807	19	5	7 + 6	ABV Trailer Control, Open Circuit	ABS WL	ESC/RSC Disabled	ECU has detected that the suspect Active Braking Valve circuit is not detected or the circuit has been interrupted.	<ul style="list-style-type: none"> <li>Verify 7.0-14.0 ohm between ABV supply and ABV common for 12V system (26.3-49.0 ohm for 24V system).</li> <li>Verify if connectors are fully seated, check for corroded or damaged wiring between the ECU and ABV.</li> <li>If SLC ECU may indicate issue with diff lock solenoid or transfer case lock solenoid.</li> </ul>

4010662a

# SPN, SID, FMI Fault Codes

Fig. 9.20

SPN	SID	FMI	Blink Code	Description	Warning Light	System Reaction	Cause	Action
807	19	6	7 + 6	ABV Trailer Control. Shorted to Ground	ABS WL	ESC/RSC Disabled	Continuity between suspect Active Braking Valve circuit and ground is detected.	<ul style="list-style-type: none"> <li>Verify 7.0-14.0 ohm between ABV supply and ABV common for 12V system (26.3-49.0 ohm for 24V system).</li> <li>Check for continuity between suspect Active Braking Valve circuit and ground.</li> <li>Check for corroded or damaged wiring between the ECU and ABV.</li> </ul>
807	19	7	7 + 6	Aux 1, 2, 3 or 4. Shorted to UBATT	ABS WL	ESC/RSC/ATC/HSA Disabled	Continuity between Auxiliary port circuits and voltage supply (short circuit) is detected.	<ul style="list-style-type: none"> <li>Verify if vehicle is equipped with Dual Trailer Stability Control Modulator Valve (ABV 3/2 solenoid + Modulator valve) or Hill Start Aid switch and lamp. Depending on the vehicle configuration, these components use Aux 1 through 4.</li> <li>Check for continuity between component and voltage supply.</li> <li>Check for corroded or damaged wiring between the ECU and component.</li> </ul>
807	19	8	7 + 6	Aux 1, 2, 3 or 4. Open Circuit	ABS WL	ESC/RSC Disabled	ECU has detected an open circuit in auxiliary port circuit or circuit was once learned and it is no longer available.	<ul style="list-style-type: none"> <li>Verify if vehicle is equipped with Dual Trailer Stability Control Modulator Valve (ABV 3/2 solenoid + Modulator valve) or Hill Start Aid switch* and lamp. Depending on the vehicle configuration, these components use Aux 1 through 4.</li> <li>HSA switch open fault detection is not activated in ECU as switch could be multiplexed.</li> <li>Check for continuity between component and ECU.</li> <li>Verify if connectors are fully seated, check for corroded or damaged wiring between the ECU and component.</li> <li>If hardwired components for Aux 1-4 are not installed on the vehicle but are checked as learned in TOOLBOX™ Software and this fault is present, the operator should perform "Reset Memorized Components" through TOOLBOX™ Software procedure.</li> <li>If SLC ECU may indicate issue with Diff lock solenoid or transfer case lock solenoid.</li> </ul>
807	19	9	7 + 6	Aux 1, 2, 3 or 4. Shorted to Ground	ABS WL	ESC/RSC Disabled	Continuity between auxiliary port circuit and ground is detected.	<ul style="list-style-type: none"> <li>Verify if vehicle is equipped with Dual Trailer Stability Control Modulator Valve (ABV 3/2 solenoid + Modulator valve) or Hill Start Aid switch* and lamp. Depending on the vehicle configuration, these components use Aux 1 through 4.</li> <li>Check for continuity between Auxiliary port component and ground.</li> <li>Verify if connectors are fully seated, check for corroded or damaged wiring between the ECU and component.</li> </ul>
807	19	10	N/A	SAS & ESC Module supply line. Shorted to UBATT	ABS WL	N/A	Continuity between SAS or ESC supply line and high voltage supply is detected.	<ul style="list-style-type: none"> <li>Verify SAS, ESC and ECU are correctly connected.</li> <li>Disconnect ECU, SAS and ESC module and check wiring between components for continuity to battery voltage with Key On.</li> <li>Check for corroded or damaged wiring between the ECU, SAS and ESC.</li> </ul>
807	19	11	8 + 6	SAS & ESC Module supply line. Open Circuit	ABS WL	N/A	ECU has detected an open circuit in between SAS or ESC supply line and ECU.	<ul style="list-style-type: none"> <li>Verify SAS, ESC and ECU are correctly connected.</li> <li>Check for corroded or damaged wiring between the ECU, SAS and ESC.</li> </ul>
807	19	12	8 + 6	SAS & ESC Module supply line. Shorted to Ground	ABS WL	ESC/RSC Disabled	Continuity between SAS or ESC supply line and ground is detected.	<ul style="list-style-type: none"> <li>Verify SAS, ESC and ECU are correctly connected.</li> <li>Disconnect ECU, SAS and ESC module and check wiring between components for continuity to ground.</li> <li>Check for corroded or damaged wiring between the ECU, SAS and ESC.</li> </ul>
810	22	8	7 + 1	Tire size broadcast error	ABS WL (Only at start up)	ABS/ESC/RSC/ATC/HSA Disabled	Tire size data has not been received from engine ECU at start up. E452 version only.	<ul style="list-style-type: none"> <li>Check availability of engine data information and communication between engine ECU and the ABS ECU.</li> <li>Contact OEM to verify engine is correctly broadcasting tire size.</li> </ul>

4010663a



# SPN, SID, FMI Fault Codes

Fig. 9.21

SPN	SID	FMI	Blink Code	Description	Warning Light	System Reaction	Cause	Action
810	22	14	3 + 7	ABS Complete Shut-off	ABS WL	Complete Shut-Off	It was detected by the ABS ECU, that the number of stored wheel speed sensor failures is greater than 100. An absence of repair is the cause of this failure. If this failure is detected, ABS completely shuts-off.	<ul style="list-style-type: none"> <li>Repair all other active faults and road test vehicle over 4 mph.</li> <li>Check sensor adjustment, condition of tone rings, wheel end play. This fault is generated by speed signal issues and usually is a wheel end issue.</li> <li>Once sensor issue has been corrected, may try to perform "Reset/Memorized" to clear code.</li> </ul>
811	23	5	7 + 4	Warning Light Relay (E-Frame)	ABS WL if grounded. Off if burned out	N/A	Output detects no load to battery or is permanently grounded.	<ul style="list-style-type: none"> <li>Verify ABS WL is working correctly during self test.</li> <li>Verify wire and/or bulb is not damaged.</li> <li>Blink code activation via switch longer than 16 sec could cause. Verify blink code switch is not permanently grounded.</li> </ul>
1045	55	3	7 + 7	Pressure Sensor Shorted to UBATT	ABS WL	ESC/RSC/ATC/HSA Disabled	Continuity between pressure signal circuit and voltage supply (short circuit) is detected.	<ul style="list-style-type: none"> <li>Verify if connectors are fully seated, check for corroded, damaged or shorted connectors or wiring between the ABS ECU and the pressure sensor.</li> <li>Verify there is no continuity between pressure sensor signal circuit and voltage supply. It could also be possible that the ECU has detected a permanent braking signal from the pressure sensor between zero to 30 mph.</li> <li>If all wiring and connector checks pass, may indicate a pressure sensor failure.</li> <li>If DTC persists after completing previous checks and repairs, may indicate the ECU has failed.</li> </ul>
1045	55	5	7 + 7	Pressure Sensor Shorted to Ground	ABS WL	ESC/RSC/ATC/HSA Disabled	Continuity between pressure signal circuit and ground (short circuit) or an open circuit is detected.	<ul style="list-style-type: none"> <li>Verify if connectors are fully seated, check for corroded, damaged or shorted connectors or wiring between the ABS ECU and the pressure sensor.</li> <li>Verify there is no continuity between pressure sensor signal circuit and ground. Verify there is 8.0-16.0 volts across pins 1-2 at the pressure sensor harness connector.</li> <li>If all wiring and connector checks pass, may indicate a pressure sensor failure.</li> <li>If no voltage is found, verify if the ECU will self-test.</li> <li>If no self-test, verify power and ground to the ECU.</li> <li>If DTC persists after completing previous checks and repairs, may indicate the ECU has failed.</li> </ul>
1045	55	7	7 + 7	CAN BLS (Brake light Switch) Signal Faulty	ABS WL	RSC Disabled	Fault only for RSC systems with ECU E440. ECU has detected the brake light switch signal is faulty.	<ul style="list-style-type: none"> <li>Refer to OEM Brake light switch troubleshooting.</li> <li>Check the BLS switch (installation, wire, connector).</li> <li>Only relevant for RSC systems without Pressure Sensor installed, with BLS over CAN Bus and ECU E440 only.</li> </ul>
1049		3		Pressure Sensor Shorted to UBATT	ABS WL	ESC/RSC/ATC/HSA Disabled	Permanent positive pressure signal detection.	<ul style="list-style-type: none"> <li>Check for continuity between pressure sensor signal circuit and voltage supply.</li> <li>Check connectors and pressure sensor for corrosion.</li> <li>It could also be possible that the ECU has detected a permanent braking signal from the pressure sensor between zero to 30 mph.</li> </ul>
1049		5		Pressure Sensor Open Circuit or Shorted to Ground	ABS WL	ESC/RSC/ATC/HSA Disabled	Permanent 0 psi pressure detection.	<ul style="list-style-type: none"> <li>Verify if connectors are fully seated, check for corroded or damaged wiring between the ECU and component.</li> <li>Check for continuity between pressure sensor signal circuit and ground.</li> <li>The pressure sensor supply line could be also clogged or frozen up.</li> <li>Call WABCO North America Customer Care at 855-228-3203 with the part number to ensure ECU is correct for the application.</li> </ul>

4010664a

# SPN, SID, FMI Fault Codes

Fig. 9.22

SPN	SID	FMI	Blink Code	Description	Warning Light	System Reaction	Cause	Action
1050		1		EAP Sensor Data Erratic or Incorrect	ATC WL	EAP Disabled	ABS system pressure is below set value.	<ul style="list-style-type: none"> <li>See EAP maintenance manual MM-1696.</li> </ul>
1052		3		EAP Pressure Sensor Shorted to UBATT	ATC WL	EAP Disabled	Continuity between pressure signal circuit and voltage supply (short circuit) is detected.	<ul style="list-style-type: none"> <li>Check for continuity between pressure sensor signal circuit and voltage supply.</li> <li>Check connectors and pressure sensor for corrosion.</li> </ul>
1052		5		EAP Pressure Sensor Shorted to Ground	ATC WL	EAP Disabled	Continuity between pressure signal circuit and ground (short circuit) or an open circuit is detected.	<ul style="list-style-type: none"> <li>Check for continuity between pressure sensor signal circuit and voltage supply.</li> <li>Check connectors and pressure sensor for corrosion.</li> </ul>
1055		3		EAP Pressure Sensor Shorted to UBATT	ATC WL	EAP Disabled	Continuity between pressure signal circuit and voltage supply (short circuit) is detected.	<ul style="list-style-type: none"> <li>Check for continuity between pressure sensor signal circuit and voltage supply.</li> <li>Check connectors and pressure sensor for corrosion.</li> </ul>
1055		5		EAP Pressure Sensor Shorted to Ground	ATC WL	EAP Disabled	Continuity between pressure signal circuit and ground (short circuit) or an open circuit is detected.	<ul style="list-style-type: none"> <li>Check for continuity between pressure sensor signal circuit and voltage supply.</li> <li>Check connectors and pressure sensor for corrosion.</li> </ul>
1056		3		ABV Trailer Shorted to UBATT	ABS WL	ESC/RSC/ATC Disabled	E8 version only Continuity between suspect Active Braking Valve circuit and voltage supply (short circuit) is detected.	<ul style="list-style-type: none"> <li>Verify 7.0-14.0 ohm between ABV supply and ABV common for 12V system (26.3-49.0 ohm for 24V system).</li> <li>Check for continuity between suspect ABV ground circuit and voltage supply.</li> <li>Check for corroded or damaged wiring between the ECU and ABV.</li> </ul>
1056		4		ABV Trailer Shorted to Ground	ABS WL	ESC/RSC Disabled	E8 version only Continuity between suspect Active Braking Valve circuit and ground is detected.	<ul style="list-style-type: none"> <li>Verify 7.0-14.0 ohm between ABV supply and ABV common for 12V system (26.3-49.0 ohm for 24V system).</li> <li>Check for continuity between suspect Active Braking Valve circuit and ground.</li> <li>Check for corroded or damaged wiring between the ECU and ABV.</li> </ul>
1056		5		ABV Trailer Open Circuit	ABS WL	ESC/RSC Disabled	E8 version only. ECU has detected that the suspect Active Braking Valve circuit is not detected or the circuit has been interrupted.	<ul style="list-style-type: none"> <li>Verify 7.0-14.0 ohm between ABV supply and ABV common for 12V system (26.3-49.0 ohm for 24V system).</li> <li>Verify if connectors are fully seated, check for corroded or damaged wiring between the ECU and ABV.</li> </ul>

4010665a

# SPN, SID, FMI Fault Codes

Fig. 9.23

SPN	SID	FMI	Blink Code	Description	Warning Light	System Reaction	Cause	Action
1069	79	1	7 + 8	Tire Pressure Monitor (TPM)	ATC WL if Parameter is set	N/A	Tire pressure loss detected by change of wheel circumference.	<ul style="list-style-type: none"> <li>Check and correct tire pressure.</li> <li>Only available if ECU has been programmed for TPM use.</li> </ul>
1204		5		No Loads Detected	ABS WL	ABS Wheel Disabled ESC/RSC/ATC/ HSA Disabled	<p>E8 version only. The ECU detects that no modulators are connected. This is a common fault during end of line testing or programming if only the X1 connector is connected.</p>	<ul style="list-style-type: none"> <li>Check harness to ensure that modulators are connected and check fuses.</li> </ul>
2622	94	2	7 + 1	HSA Active Fault	HSA WL	HSA Disabled	<p>It was detected that HSA was continuously active for more than 90s or ECU detected no HSA switch information in the EBC1 Message if switch is multiplexed.</p>	<ul style="list-style-type: none"> <li>Verify if ECU is correct for vehicle application.</li> <li>Contact vehicle OEM to verify broadcast of HSA switch is correct.</li> </ul>
<b>ESC</b>								
520210	88	1	N/A	ESC Initialization Not Complete	ATC WL Blinking	ESC Disabled	<p>ECU has recognized that the ESC module is currently in initialization mode and has not been completed.</p>	<ul style="list-style-type: none"> <li>Follow the ESC Initialization (End of Line) calibration.</li> </ul>
520210	88	2	8 + 6	ESC System Configuration	ATC WL	ESC Disabled	<p>The ESC module is not compatible with the ABS ECU.</p>	<ul style="list-style-type: none"> <li>Verify correct ABS ECU with OEM.</li> </ul>
520210	88	5	7 + 1	ESC CAN Datalink Fault	ATC WL	ESC Disabled	<p>Loss of CAN communication between the ESC module and the ABS ECU.</p>	<ul style="list-style-type: none"> <li>Check CAN wiring between ABS-ECU and ESC-module for interruptions and short circuits.</li> <li>Check CAN wiring between ABS-ECU and SAS for interruptions and short circuits.</li> <li>Check for corroded or damaged wiring between the ECU, SAS and ESC Module.</li> </ul>
520210		7		ESC Module Mounting Fault	ATC WL	ESC Disabled	<p>E8 version only. The ESC module mounting is not in accordance with specification.</p>	<ul style="list-style-type: none"> <li>Verify ESC module is securely mounted, leveled and in correct location. Contact WABCO North America Customer Care at 855-228-3203 to ensure ESC module mounting is in accordance with ABS ECU parameters.</li> </ul>

4010666a

# SPN, SID, FMI Fault Codes

Fig. 9.24

SPN	SID	FMI	Blink Code	Description	Warning Light	System Reaction	Cause	Action
520210	88	9	7 + 1	ESC CAN messages missing, data erratic or incorrect	ATC WL	ESC Disabled	Data communication between the ESC module, SAS and the ABS ECU is missing or incorrect.	<ul style="list-style-type: none"> <li>Check CAN wiring between ABS-ECU and ESC-module for interruptions and short circuits.</li> <li>Check CAN wiring between ABS-ECU and SAS for interruptions and short circuits.</li> <li>Check for corroded or damaged wiring between the ECU, SAS and ESC Module.</li> </ul>
520210		10		ESC Plausibility	ATC WL	ESC Disabled	The ESC system detects a plausibility issue while driving (straight line).	<ul style="list-style-type: none"> <li>Check that SAS and ESC module are correctly mounted, leveled, and in correct location. Contact WABCO North America Customer Care at 855-228-3203 to ensure ESC module and SAS are mounted in accordance with ECU parameters.</li> </ul>
520210	88	12	8 + 6	ESC System Failure	ATC WL	ESC Disabled	ECU has detected ESC system failure due to missing or incorrect data from ESC Module or SAS.	<ul style="list-style-type: none"> <li>Check CAN wiring between ABS-ECU, ESC-module and SAS for interruptions and short circuits.</li> <li>Check for corroded or damaged wiring between the ECU, SAS and ESC Module.</li> <li>Check for stray single power wires on or near the ESC module.</li> <li>Check for damaged or incorrectly mounted SAS.</li> <li>Verify ESC module is securely mounted, leveled and in correct location.</li> <li>Verify ABS ECU and ESC has been correctly calibrated. Follow the ESC Initialization (End of Line) calibration. Refer to Section 8.</li> </ul>
520210	88	13	8 + 6	ESC Initialization required	ATC WL	ESC Disabled	The system has detected that the ABS ECU, ESC module or parameters were exchanged and ESC initialization is required.	<ul style="list-style-type: none"> <li>Follow the ESC Initialization (End of Line) calibration.</li> </ul>
520210	88	14	8 + 6	ESC Module Mounting Fault	ATC WL	ESC Disabled	E4 version: The ESC module mounting is not in accordance with specification. E8 version: ESC Initialization not Completed.	<ul style="list-style-type: none"> <li>E4 version: Verify ESC module is securely mounted, leveled and in correct location. Contact WABCO North America Customer Care at 855-228-3203 to ensure ESC module mounting is in accordance with ABS ECU parameters.</li> <li>E8 version: Follow the ESC Initialization (End of Line) calibration procedure for E8 version ECUs.</li> </ul>
520211		7		Liftaxle Plausibility Fault	ATC WL	ESC Disabled	The system has detected that the ABS ECU parameters are not plausible.	<ul style="list-style-type: none"> <li>Contact WABCO North America Customer Care at 855-228-3203 to ensure that the ECU parameter setting is correct for the vehicle.</li> </ul>
1807	89	1	8 + 6	SAS Offset Fault	ATC WL	ESC Disabled	The Steering Angle Sensor offset is out of tolerance.	<ul style="list-style-type: none"> <li>Check for damaged or incorrectly mounted SAS.</li> <li>If work has been performed on the vehicle which affects the steering system or front end alignment, perform SAS Calibration and ESC Initialization. Refer to Section 8.</li> </ul>
1807	89	2	8 + 6	SAS Not Plausible	ATC WL	ESC Disabled	The ESC module has detected an implausible steering angle compared to the measured yaw rate.	<ul style="list-style-type: none"> <li>Check for correct mounting of the SAS and ESC module.</li> </ul>

4010667a

# SPN, SID, FMI Fault Codes

Fig. 9.25

SPN	SID	FMI	Blink Code	Description	Warning Light	System Reaction	Cause	Action
1807		4		SAS Datalink Fault	ATC-WL	ESC Disabled	The steering wheel angle signal is not available after ignition on.	<ul style="list-style-type: none"> <li>Check CAN wiring between ABS-ECU and SAS for interruptions and short circuits.</li> <li>Check for corroded or damaged wiring between the SAS and ESC Module.</li> <li>Contact WABCO North America Customer Care at 855-228-3203 to check parameter setting of ABS ECU and SAS compatibility.</li> </ul>
1807	89	7	8 + 6	Steering Ratio Fault	ATC-WL	ESC Disabled	The calculated steering ratio of the vehicle is not plausible.	<ul style="list-style-type: none"> <li>Check for correct mounting of the SAS and ESC module.</li> <li>If work has been performed on the vehicle which affects the steering system or front end alignment, perform SAS Calibration and ESC Initialization. Refer to Section 8.</li> </ul>
1807	89	8	7 + 1	SAS Calibration Fault	ATC-WL	ESC Disabled	The Steering Angle Sensor calibration failed.	<ul style="list-style-type: none"> <li>Verify SAS is correctly mounted.</li> <li>Perform SAS Calibration and ESC Initialization. Refer to Section 8.</li> </ul>
1807	89	9	7 + 1	SAS CAN Fault	(temp) ATC-WL	ESC Disabled (temp possible)	Data communication faults with ESC module.	<ul style="list-style-type: none"> <li>Check harness between ABS ECU and SAS.</li> <li>Check parameter setting of ABS ECU.</li> <li>Check SAS operation if fault persists.</li> </ul>
1807	89	12	8 + 6	SAS Failure	ATC-WL	ESC Disabled	The Steering Angle Sensor is communicating an internal error to the ABS ECU.	<ul style="list-style-type: none"> <li>Check CAN wiring between ABS-ECU and SAS for interruptions and short circuits.</li> <li>Check for corroded or damaged wiring between the SAS and ESC Module.</li> </ul>
1807	89	13	8 + 6	SAS not Calibrated	ATC-WL	ESC Disabled	The ECU has detected that SAS is out of calibration.	<ul style="list-style-type: none"> <li>Follow the SAS calibration procedure. Refer to Section 8.</li> </ul>
1807	89	14	8 + 6	SAS Internal Fault	ATC-WL	ESC Disabled	The Steering Angle Sensor is communicating an internal error to the ABS ECU.	<ul style="list-style-type: none"> <li>Check the installation and condition of the SAS and steering system.</li> </ul>
3509		3		SAS and ESC Module Supply Shorted to UBATT	ATC-WL	ESC Disabled	Continuity between suspect ESC supply circuit and voltage supply (short circuit) is detected.	<ul style="list-style-type: none"> <li>Check CAN wiring between ABS-ECU and SAS for interruptions and short circuits.</li> <li>Check for corroded or damaged wiring between the SAS and ESC Module.</li> <li>Contact WABCO North America Customer Care at 855-228-3203 to check parameter setting of ABS ECU and SAS compatibility.</li> </ul>
3509		4		SAS and ESC Module Supply Shorted to Ground	ATC-WL	ESC Disabled	Continuity between suspect ESC supply circuit and ground is detected.	<ul style="list-style-type: none"> <li>Check CAN wiring between ABS-ECU and SAS for interruptions and short circuits</li> <li>Check for corroded or damaged wiring between the SAS and ESC Module.</li> <li>Contact Meritor OnTrac™ Customer Call Center at 866-OnTrac1 (868-7221) to check parameter setting of ABS ECU and SAS compatibility.</li> </ul>

4010668a

# SPN, SID, FMI Fault Codes

Fig. 9.26

SPN	SID	FMI	Blink Code	Description	Warning Light	System Reaction	Cause	Action
<b>Datalink J1939</b>								
639	231	2	7 + 1	SAE J1939 Data Link VSC1 Speed Erratic, Intermittent or Incorrect	ABS WL	N/A	Received vehicle speed and ABS vehicle speed is incorrect. Supervision normally not activated.	<ul style="list-style-type: none"> <li>Check tire size and verify ECU is for the correct vehicle application.</li> </ul>
639	231	5	7 + 1	SAE J1939 Data Link Open or Short Circuit	ABS WL	ESC/RSC/ATC/ HSA Disabled	SAE J1939 communication is not possible.	<ul style="list-style-type: none"> <li>If ABS ECU is only vehicle ECU not communicating, verify J1939 wiring between ABS ECU and J1939 backbone.</li> <li>Resistance should be 60 ohms between J1939 high and low.</li> <li>Key on, check voltage to ground at the ECU harness connector J1939 pins and verify the high side has 2.5 to 5 volts and the low side has 2.49 volts or less. The readings will fluctuate but should be in range and should never be the same. The total of both readings together should be approximately 5 volts.</li> </ul>
639	231	6	7 + 1	SAE J1939 No Access	ABS WL	ESC/RSC/ATC/ HSA Disabled	SAE J1939 communication is not possible.	<ul style="list-style-type: none"> <li>If ABS ECU is only vehicle ECU not communicating, verify J1939 wiring between ABS ECU and J1939 backbone.</li> <li>Resistance should be 60 ohms between J1939 high and low.</li> <li>Key on, check voltage to ground at the ECU harness connector J1939 pins and verify the high side has 2.5 to 5 volts and the low side has 2.49 volts or less. The readings will fluctuate but should be in range and should never be the same. The total of both readings together should be approximately 5 volts.</li> </ul>
639	231	9	7 + 1	SAE J1939 Data Link EEC1 Timeout	ABS WL	ESC/RSC/ATC/ HSA Disabled	There is either too much time in between EEC1 broadcasts from the engine or the message content is not as expected.	<ul style="list-style-type: none"> <li>Contact OEM to verify J1939 wiring between engine ECU and vehicle J1939 backbone is correct and messages are correct.</li> <li>If ABS ECU is only vehicle ECU not communicating, verify J1939 wiring between ABS ECU and J1939 backbone.</li> <li>Resistance should be 60 ohms between J1939 high and low.</li> <li>Key on, check voltage to ground at the ECU harness connector J1939 pins and verify the high side has 2.5 to 5 volts and the low side has 2.49 volts or less. The readings will fluctuate but should be in range and should never be the same. The total of both readings together should be approximately 5 volts.</li> </ul>
639	231	10	7 + 1	SAE J1939 XBR Timeout	Temporary ABS WL	XBR Disabled	The external brake request message (XBR) is expected but is not being received in expected time or not at all.	<ul style="list-style-type: none"> <li>Verify J1939 wiring between external ECU which is sending request and J1939 backbone.</li> <li>This message is most likely to come from Adaptive Cruise or a Collision Mitigation System such as OnGuard™.</li> </ul>
639	231	12	7 + 1	SAE J1939 Internal Error	ABS WL	ABS Wheel Disabled ESC/RSC/ATC/ HSA Disabled	An internal fault related to the CAN controller is detected.	<ul style="list-style-type: none"> <li>Verify J1939 wiring between ABS ECU and J1939 backbone.</li> <li>Resistance should be 60 ohms between J1939 high and low.</li> <li>Key on, check voltage to ground at the ECU harness connector J1939 pins and verify the high side has 2.5 to 5 volts and the low side has 2.49 volts or less. The readings will fluctuate but should be in range and should never be the same. The total of both readings together should be approximately 5 volts.</li> </ul>
639	231	13	7 + 1	SAE J1939 XBR Timeout	Temporary ABS WL	XBR Disabled	The external brake request message (XBR) has been received incorrectly.	<ul style="list-style-type: none"> <li>Verify J1939 wiring between external ECU which is sending request and J1939 backbone.</li> <li>This message is most likely to come from Adaptive Cruise or a Collision Mitigation System such as OnGuard™.</li> </ul>

4012655a

# SPN, SID, FMI Fault Codes

Fig. 9.27

SPN	SID	FMI	Blink Code	Description	Warning Light	System Reaction	Cause	Action
639	231	14	7 + 1	SAE J1939 Data Link ESC1 Timeout	ATC WL	ESC Disabled	The electronic steering control message (ESC1) is expected but is not being received in expected time or not at all.	<ul style="list-style-type: none"> <li>Verify J1939 wiring between external ECU which is sending request and J1939 backbone.</li> <li>This message is most likely to come from a steering tag axle controller.</li> </ul>
<b>Internal</b>								
627	251	3	8 + 2	Overvoltage	ABS WL	ABS Wheel Disabled ESC/RSC/ATC/ HSA Disabled	A supply voltage which is too high has been measured by the ECU for more than 5 seconds.	<ul style="list-style-type: none"> <li>Measure the battery or ignition voltage under load. Check the vehicle battery and associate components (alternator).</li> <li>Check the battery and ensure it is correct for the ECU, i.e., ensure a 24V battery is not being used with a 12V ECU</li> <li>Check for corroded or damaged wiring between the ECU and voltage supply as well as ground path.</li> </ul>
631		2		ABS System Configuration EEPROM Wheel Parameter Incorrect	ABS WL	ABS Wheel Disabled ESC/RSC/ATC/ HSA Disabled	E8 Version only. The ECU memorized system is not in accordance with the harness. There are loads detected at outputs which should be open circuits. Wheel parameters (number of tone ring teeth or tire size) are out of tolerance.	<ul style="list-style-type: none"> <li>Check number of sensors and modulators and correct wiring compared to ECU type.</li> <li>Call WABCO North America Customer Care at 855-228-3203 with part number to ensure ECU is correct for the application.</li> </ul>
630	253	1	7 + 5	ATC Configuration Issue	ABS WL	ATC Disabled	ABS ECU can see ATC valve but not the data link.	<ul style="list-style-type: none"> <li>Verify data link circuit voltage and resistance.</li> <li>Try engine derate test. If test fails, indicates issue with data link circuit.</li> </ul>
630	253	2	8 + 2	Incorrect ABS System Configuration. EEPROM or Wheel Parameter Incorrect	ABS WL	ABS Wheel Disabled ESC/RSC/ATC/ HSA Disabled	The ECU memorized system is not in accordance with the harness. There are loads detected at outputs which should be open circuits. Wheel parameters (number of tone ring teeth or tire size) are out of tolerance.	<ul style="list-style-type: none"> <li>Check number of sensors, modulators, 3/2 valves and other components match ECU configurations. (Parameters and installed components are not matching).</li> <li>Verify the installed wheel size matches ECU wheel parameter.</li> <li>On E452 ECUs with tire data available on request: check Engine ECU, availability of engine data information and communication between Engine ECU and the ABS ECU.</li> </ul>

4012656a

# SPN, SID, FMI Fault Codes

Fig. 9.28

SPN	SID	FMI	Blink Code	Description	Warning Light	System Reaction	Cause	Action
630	253	12	8 + 4	EEPROM Checksum	ABS WL	ABS Wheel Disabled ESC/RSC/ATC/ HSA Disabled	There is an incorrect checksum in the EEPROM. A diagnostic tool may have been disconnected during active diagnosis or programming.	<ul style="list-style-type: none"> <li>Reset ECU by cycling the ignition or by using the reset option in TOOLBOX™.</li> <li>Retry the programming that was being attempted.</li> </ul>
630	253	13	8 + 4	ABS System Fault	ABS WL	ABS Wheel Disabled ESC/RSC/ATC/ HSA Disabled	The ECU memorized system is not in accordance with the harness.	<ul style="list-style-type: none"> <li>Check number of sensors and modulators and correct wiring compared to ECU type.</li> </ul>
630	253	14	8 + 6	EEPROM ESC Parameter Incorrect	ABS WL	ESC Disabled	The stability control parameters set in the ECU are not in accordance with what is detected or learned on the vehicle.	<ul style="list-style-type: none"> <li>Contact vehicle OEM to obtain correct ECU part number for vehicle.</li> </ul>
629	254	5	8 + 4	No Loads Detected	ABS WL	ABS Wheel Disabled ESC/RSC/ATC/ HSA Disabled	The ECU detects that no modulators are connected. This is a common fault during end of line testing or programming if only the X1 connector is connected.	<ul style="list-style-type: none"> <li>Check harness to ensure that modulators are connected and check fuses.</li> </ul>
629	254	8	7 + 1	Excessive Slip	ABS WL	ABS Wheel Disabled ESC/RSC/ATC/ HSA Disabled	One axle is detected to be rotating much faster than another. This fault is common if vehicle has been on a dyno and detection is not disabled via diagnostic command. It is also possible that there are excessive sensor air gaps on multiple wheel ends.	<ul style="list-style-type: none"> <li>Use the "Disable ATC" diagnostic command when the vehicle is on a Dyno.</li> <li>Check for excessive ABS sensor gap on multiple wheel ends.</li> </ul>

4012657a



# SPN, SID, FMI Fault Codes

Fig. 9.29

SPN	SID	FMI	Blink Code	Description	Warning Light	System Reaction	Cause	Action
629	254	9	2 + 1	Excessive Modulator Activation Time	ABS WL	ABS Wheel Disabled ESC/RSC Disabled ATC Disabled if Fault on Driven Wheel	An ABS modulator was activated for an abnormally long time.	<ul style="list-style-type: none"> <li>Adjust wheel sensor to touch tone ring.</li> <li>Check condition of ABS sensor head.</li> <li>Check for loose wheel bearings or excessive hub runout.</li> <li>Check mounting of ABS tone ring and condition of teeth.</li> <li>Check condition and retention of ABS sensor spring clip.</li> <li>Check ABS sensor cable routing and clipping.</li> </ul>
629	254	12	8 + 3	Internal Error	ABS WL	ABS Wheel Disabled ESC/RSC/ATC/HSA Disabled	There are multiple causes. Valves may have been activated too long during diagnostic testing. Internal ECU communication is not correct.	<ul style="list-style-type: none"> <li>Reset ECU by cycling the ignition or by using the reset option in TOOLBOX™.</li> <li>If fault persists, check ABS ECU powers, grounds and load test.</li> <li>After checking powers, grounds and load testing, if fault still persists may indicate the ECU has failed.</li> </ul>
629	254	13	8 + 6	Accelerometer Out of Range	ABS WL	RSC Disabled	The measured lateral acceleration by the ECU is out of range.	<ul style="list-style-type: none"> <li>Verify that the ECU is securely mounted, leveled and in correct location as per OEM specification.</li> <li>Reset ECU by cycling the ignition or by using the reset option in TOOLBOX™.</li> </ul>
629	254	14	8 + 6	ECU Mounting, Accelerometer Not Plausible	ABS WL	RSC Disabled	The measured lateral acceleration is not plausible or the learned offset is too high. ECU may be mounted incorrectly.	<ul style="list-style-type: none"> <li>Verify that the ECU is securely mounted, leveled and in correct location as per OEM specification.</li> <li>Reset ECU by cycling the ignition or by using the reset option in TOOLBOX™.</li> </ul>

4012658a

## 10 Appendix I

### 10.1 Reconfiguration Procedure

#### 10.1.1 How to Reconfigure an ECU (E Version)

Before reconfiguring the ECU, contact the WABCO Customer Care Center at 855-228-3203 for additional information.

E version ECUs will automatically learn and memorize the following components if they are connected at start up:

- ATC valve
- Retarder relay or third brake relay
- Datalink SAE J1939
- Auxiliary inputs and outputs 1-5



Depending on the ECU configuration (RSC, ESC or HSA), ATC Valve and auxiliary 1 through 5 cannot be reconfigured to remove these components. Only the retarder relay is memorized or cleared.

Once these components have been memorized, the ECU will look for them at each start up. If a memorized component is not present, the ECU will record a fault. For example, if an ATC valve is memorized, but is not present at the next start up, the ECU records a fault. This can occur if an ECU is moved from one truck to another and one or more of the memorized components are not available on the new truck. If this occurs, use TOOLBOX™ Software to reconfigure the ECU. If you do not have TOOLBOX™ Software, follow the manual reconfiguration instructions in this section.

#### 10.1.2 TOOLBOX™ Software

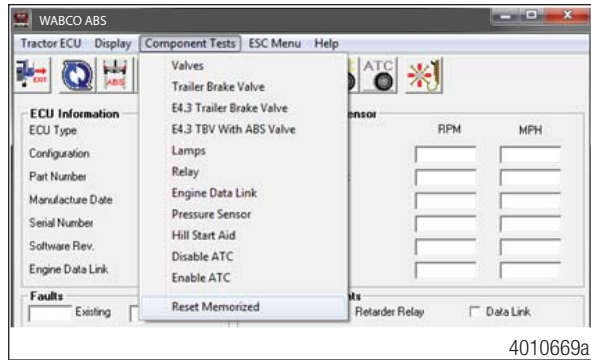


For complete instructions for using TOOLBOX™ Software, refer to the TOOLBOX™ User's Manual, TP-99102.

To reconfigure the ECU with TOOLBOX™ Software, use the **Reset Memorized** command.

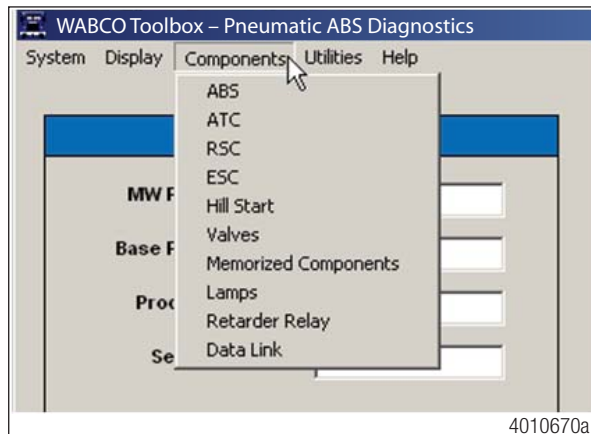
Select **Reset Memorized** from the pull-down menu to tell the ECU to reset the memorized or “learned” components. Figure 10.1. If you are using TOOLBOX™ Software version 11 or higher, choose Components, Memorized Components and Reset Memorized. Figure 10.2 and Figure 10.3.

Fig. 10.1



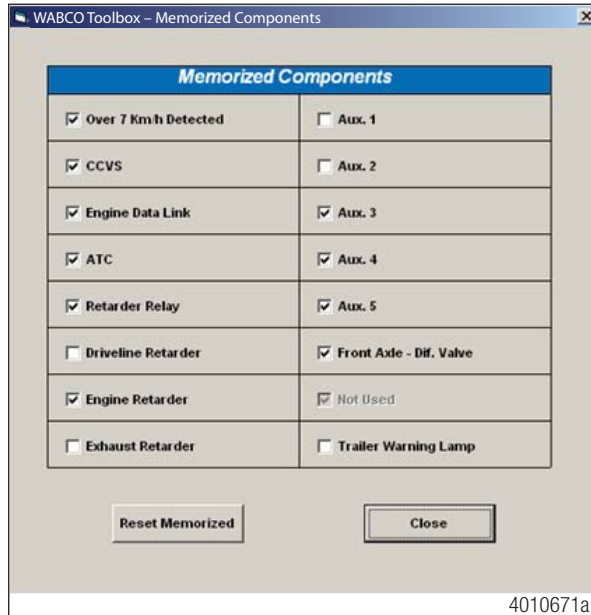
4010669a

Fig. 10.2



4010670a

Fig. 10.3



4010671a



Vehicle Ignition must be cycled and vehicle test driven over 4 mph (6.4 kph) to complete reset memorization.

## 10.1.3 Manual Reconfiguration

Refer to Table C and Figure 10.4 for information on manual reconfiguration.

Table C

Action	Result	Reason
<p><b>1. Turn the ignition ON.</b></p> <p><b>2. Press and hold the blink switch for at least three seconds.</b></p> <p><b>NOTE:</b> Do not hold this switch longer than seven seconds.</p>	<p>The ABS lamp displays the ABS system configuration code:</p> <ul style="list-style-type: none"> <li>■ One blink: 6S/6M 6X2</li> <li>■ Two blinks: 4S/4M</li> <li>■ Four blinks: 6S/4M</li> <li>■ Five blinks: 6S/6M 6X4</li> </ul> <p><b>NOTE:</b> The ABS lamp may display eight quick flashes before the system configuration code begins.</p>	<p>Stored faults cleared, no active faults present. Continue with reconfiguration.</p> <p><b>NOTE:</b> The reconfiguration procedure cannot be conducted if there are active faults present. These must be repaired before proceeding with the reconfiguration.</p>
<p><b>Observe the ABS and ATC lamps.</b></p>	<p>The ATC lamp comes on and stays on.</p>	<p>A complete ATC system — including an ATC lamp — is installed. If not, the ATC lamp will not come on.</p>
	<p>The ABS lamp will continuously blink the system configuration code.</p>	<p>ECU reconfiguring the system.</p> <p>The ECU checks the following components and reprograms itself based on the new system:</p> <ul style="list-style-type: none"> <li>■ ATC valve</li> </ul> <p>AND/OR</p> <ul style="list-style-type: none"> <li>■ Retarder relay</li> </ul> <p>AND/OR</p> <ul style="list-style-type: none"> <li>■ Datalink J1939</li> </ul>
<p><b>While the configuration code is flashing, press the blink code switch three times (one second each, with a one second pause between each).</b></p> <p><b>Turn the ignition OFF.</b></p>	<p>The ABS lamp displays <b>four quick flashes</b>, followed by a continuous display of the system configuration code.</p> <p><b>NOTE:</b> The system configuration code continues until ignition is turned OFF</p>	<p>Successfully reconfigured.</p>



# 11 Appendix II

## 11.1 E4 ESC End of Line Calibration Procedure

This procedure is performed as part of the final assembly of the vehicle at the manufacturing site. Also, this procedure must be performed in the field by a trained technician if components are replaced such as the Steering Angle Sensor (SAS), the Electronic Stability Control (ESC) module or the ESC Electronic Control Unit (ECU). This calibration should also be performed when a major steering repair or replacement has taken place.

The process consists of two operations. The first one is the SAS Calibration while the vehicle is stationary, followed by the ESC Initialization while driving the vehicle. The status of the ESC End of Line (EOL) procedure can be verified using one of the following allowed faults.

- SAS not calibrated — SID 89, FMI 13
- ESC initialization required — SID 88, FMI 13
- ESC initialization not completed — SID 88, FMI 1

### CAUTION

Additional faults must not be active. Any other faults must be resolved before one of the main menu items is available



To prevent incorrect activations, SAS Calibration and ESC Initialization must be done separately. It is necessary to perform the SAS calibration prior to the ESC initialization.

For any questions or assistance, please contact the WABCO Customer Care at Center at 855-228-3203 or visit [wabco-na.com](http://wabco-na.com) for further details.

### 11.1.1 SAS Calibration



The SAS Calibration must be done after a front wheel alignment has been performed.

Depending on the software version used, there will be two options to communicate with the vehicle:

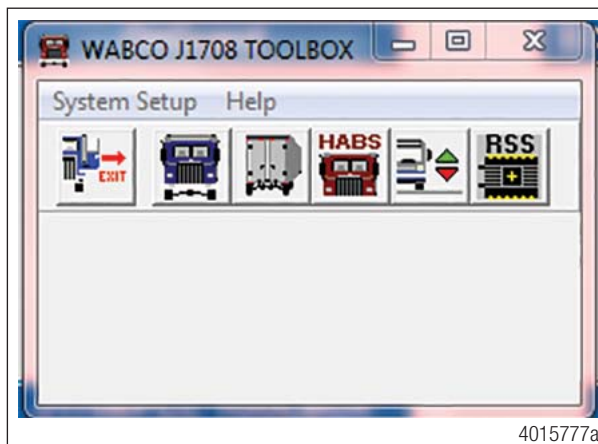
- If you are using TOOLBOX™ Software version 11 or higher and a vehicle with ECUs E4.4b or higher, Tractor ABS J1939 communications can be possible. Figure 11.1.

- J1708 communications are possible with any TOOLBOX™ Software version and any ABS ECU. Figure 11.2.

Fig. 11.1

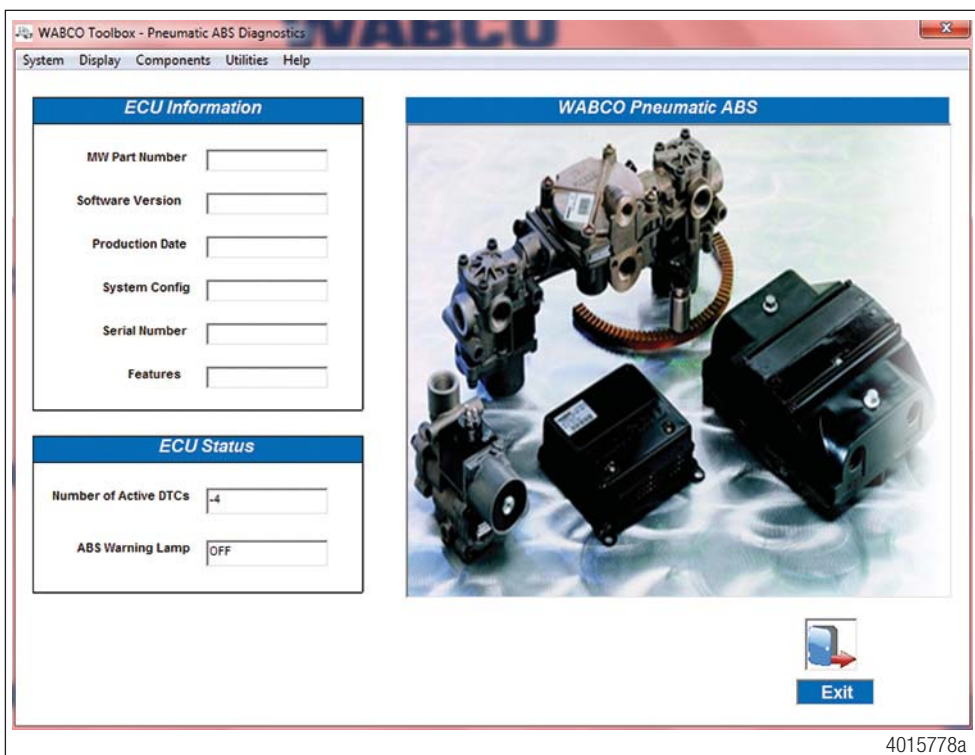


Fig. 11.2



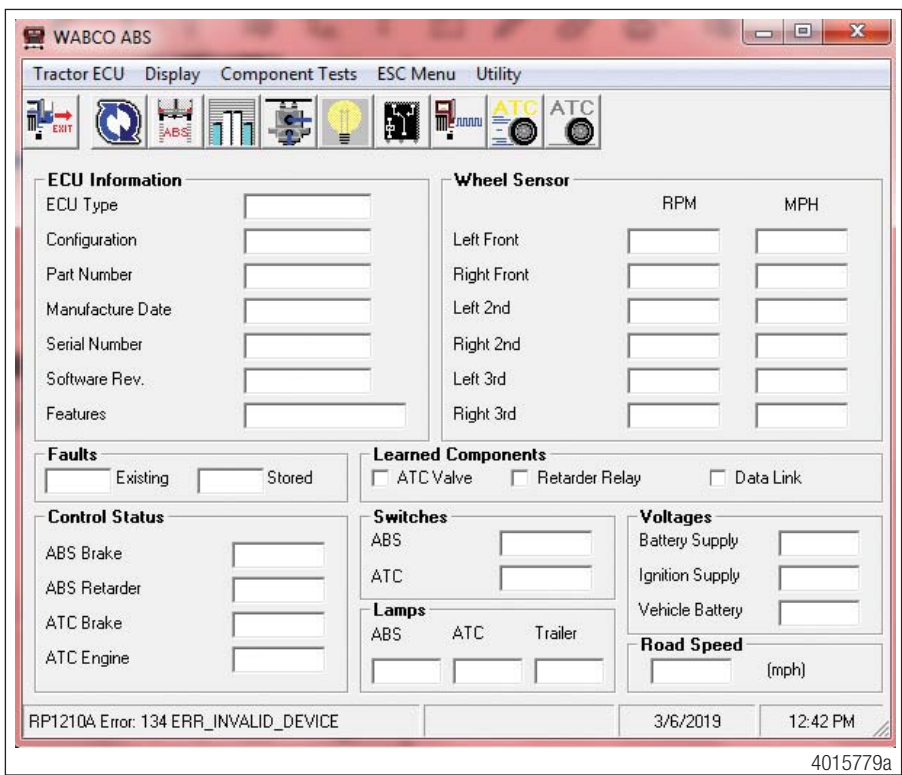
In the Main Menu, select J1939 Tractor ABS or J1708 TOOLBOX™, then Tractor ABS. The ABS Main Screen will appear. Figure 11.3 and Figure 11.4.

Fig. 11.3



4015778a

Fig. 11.4



4015779a

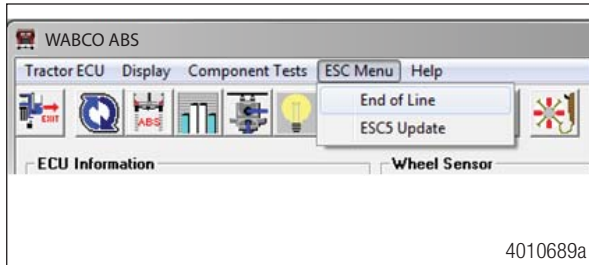


# Appendix II

To access the ESC EOL:

- From the bar menu at the initial screen, click on the “ESC Menu” button. A drop-down box will appear. Select the option “End of Line.” Figure 11.5.

Fig. 11.5



If you are using TOOLBOX™ Software version 11 or higher, click on “Components” button. A drop box will appear, Select “ESC” then select “Start EOL”. Figure 11.6 and Figure 11.7.

Fig. 11.6

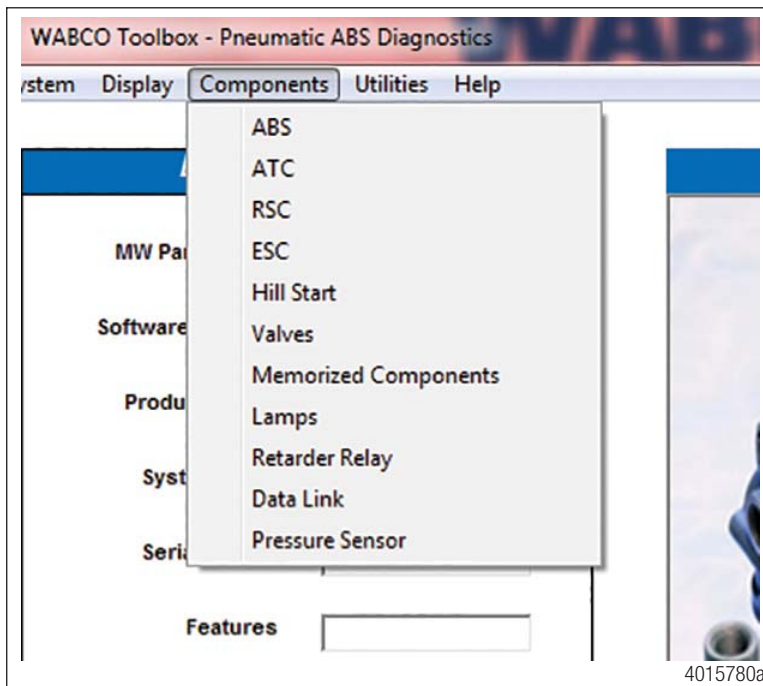
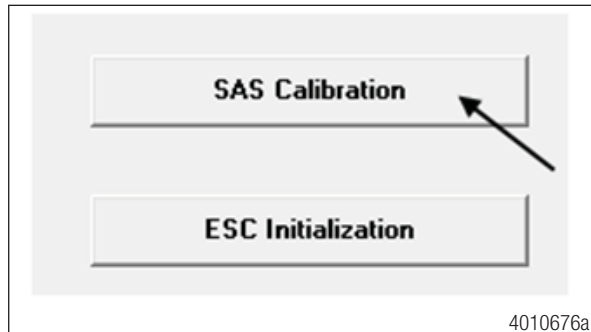


Fig. 11.7



In the message box that appears, click the “SAS Calibration” button. Figure 11.8.

Fig. 11.8

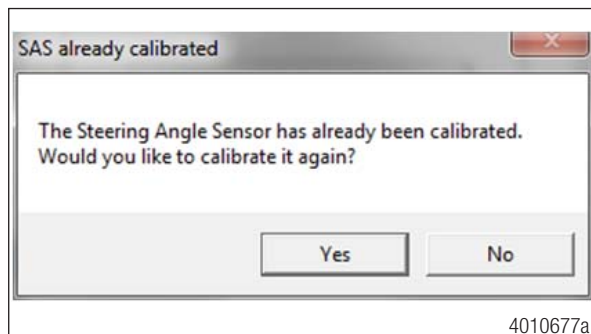


If SAS has NOT been replaced but vehicle has had an alignment performed or other steering components have been replaced, it is necessary to recalibrate SAS regardless of current calibration. Figure 11.9 may appear if unit has had SAS calibrate at some point. Click on Yes to recalibrate SAS. Figure 11.10.

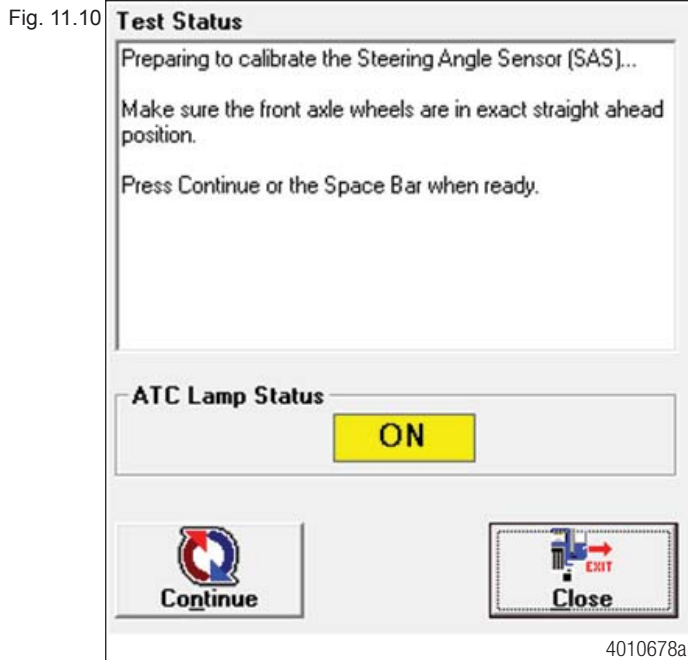


The vehicle needs to be sitting still during SAS calibration.

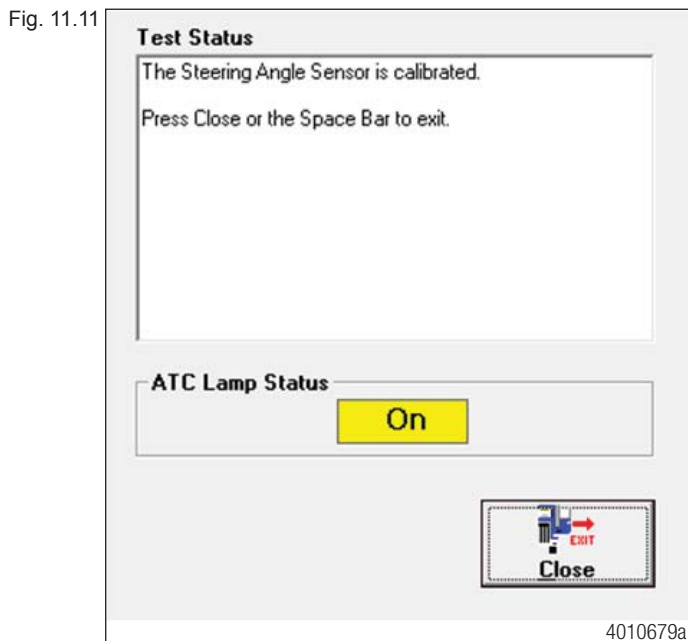
Fig. 11.9



Depending on your version of TOOLBOX™ Software, the message in Figure 11.9 may appear. If it does, always click “Yes” to recalibrate the Steering Angle Sensor in order to complete the ESC Initialization.



The message will let you know when the SAS has been calibrated. Once the SAS is calibrated, press the "Close" button or the space bar to continue. Figure 11.11.



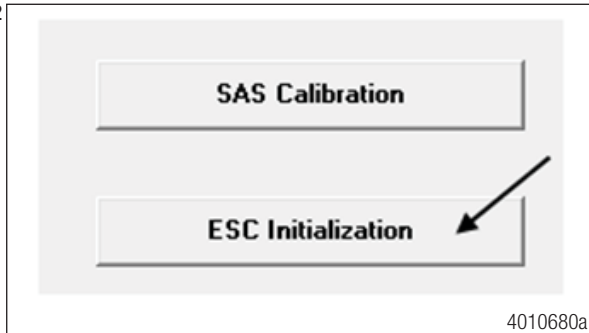
The SAS calibration is now completed. The ATC lamp will blink continuously to inform driver ECU is in learning mode.

If SAS calibration fails; recheck the SAS connection and verify SAS mounting. Cycle ignition and retry SAS calibration again.

## ESC Initialization

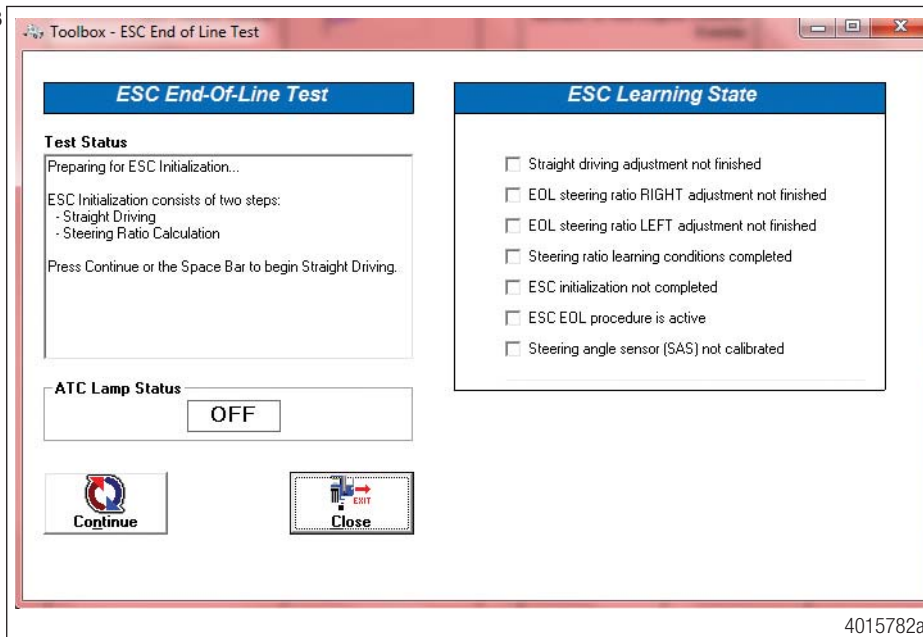
Access the ESC EOL menu as in SAS calibration but instead in the message box that appears, click the “ESC Initialization” button. Figure 11.12.

Fig. 11.12



Check the message box that appears. Press the space bar or click the “Continue” button when ready to proceed. Figure 11.13. The ATC lamp will start blinking to inform driver ECU is in learning mode.

Fig. 11.13

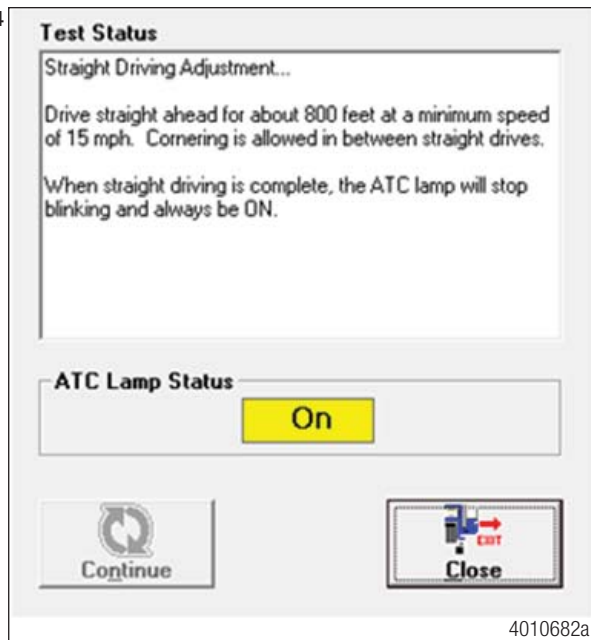


Carefully follow the instructions that appear in the message box. Figure 11.13. Once the ESC initialization is started, the messages will automatically change as the requirements are met. DO NOT click the “continue” button again as this may cause the process to fail. The ESC Initialization procedure requires the vehicle to be driven.



If SAS calibration was completed before ESC initialization, the ATC lamp will be continuously blinking before ESC initialization begins. Figure 11.14.

Fig. 11.14



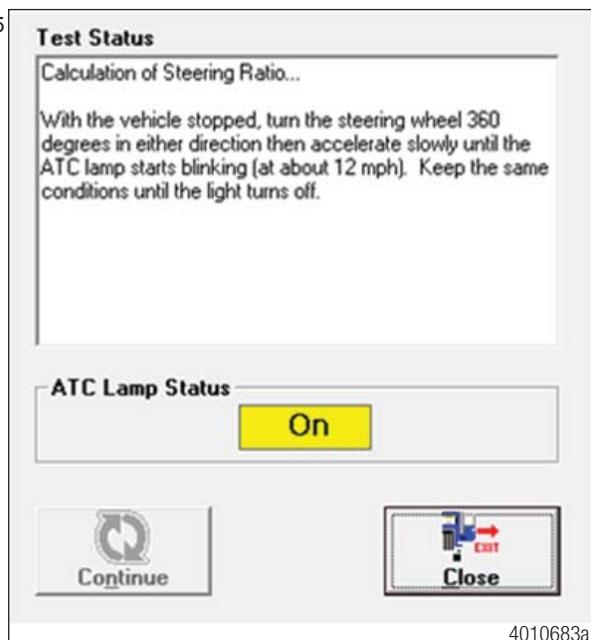
The straight driving adjustment can be done in segments as the ECU will accumulate the information until the 800 feet is reached. Cornering and stopping is allowed as long as calibration is done within the same ignition cycle.

When the Straight Driving Adjustment is completed after ECU accumulated 800 feet of straight driving, the ATC lamp will stop blinking and will remain ON.

**i** Certain vehicles may not require you to perform the turning portion of the ESC initialization steering ratio calculation process. For these vehicles, the ATC lamp will go out. Follow the instructions on the screen.

The screen will automatically change to the next portion of the procedure. Figure 11.15.

Fig. 11.15





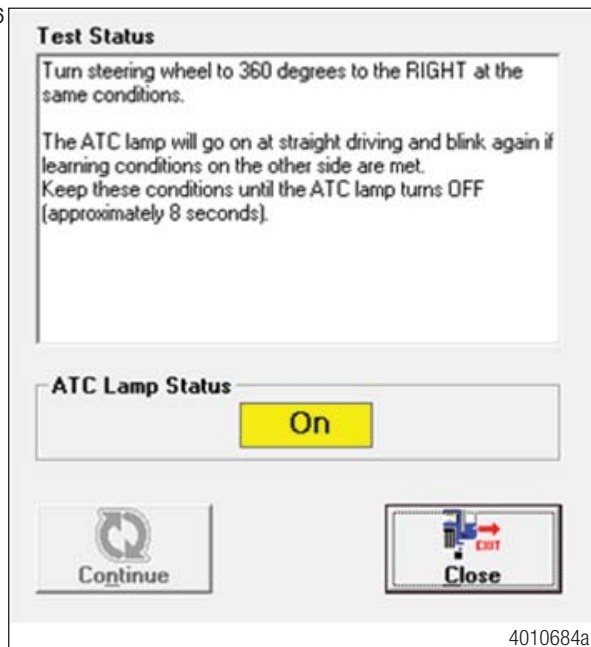
The vehicle **MUST** come to a complete stop before starting the steering ratio calculation and turning the steering wheel 360 degrees for the first time.

Once steering wheel is turned one revolution in either direction (360 degrees) accelerate slowly until 12 mph (19 kph) is reached.

Continue driving in a circle until the screen automatically changes to inform the steering ratio is being calculated. Maintain the vehicle speed and conditions (approximately 8 seconds) until ATC lamp turns off.

The screen will automatically change to the next portion of the procedure. Figure 11.16.

Fig. 11.16



The vehicle does not have to come to a complete stop before turning the steering wheel 360 degrees in the other direction but it is recommended to make sure wheels are in the straight position before making the turn.

Turn the steering wheel 360 degrees in the opposite direction and repeat the driving conditions. The ATC lamp will start blinking when the required conditions are met. Keep driving in those conditions (approximately 8 seconds) until the lamp turns off.

The screen will automatically change to show ESC End of the Line data and ratios. Figure 11.17.

Make sure to stop the vehicle once steering ratio calculation has been completed.



The circle driving (Calculation of Steering Ratio) can be done in segments as the ECU will accumulate the information until the desired distance is reached, but must be done within the same ignition cycle. The calibration requires driving in both directions with the steering wheel rotated 360 degrees.

Fig. 11.17

ESC End of Line Data

Steering Ratio Left	20.8
Steering Ratio Right	21.0
Steering Angle Offset	1.0

Enter Vehicle Number

Enter Comments (optional)

4010685a

With the vehicle stopped, ESC End of Line Data with the Steering Ratios and Steering Angle Offset values will appear. The data can be saved or printed for maintenance records. If saving or printing is not desired, click “Close”. The next screen will automatically appear to complete the ESC initialization. Figure 11.18.

Fig. 11.18

**Test Status**

To finalize the ESC initialization it is necessary to cycle the ignition or the calculated values will be lost!  
Please close this window and **CYCLE THE IGNITION**.  
Press Close to exit.

**ATC Lamp Status**

Off

4010686a

For the ECU to be able to save ratios and ESC EOL data, the ignition **MUST** be cycled. With the vehicle stopped, close window that appeared and cycle the ignition for around 10 seconds.



Power down cycle time and sequence will vary amongst vehicle manufacturers. Some vehicles might require the key to be removed from the ignition for ignition power to be completely turned off. Please follow the vehicle manufacturer procedure to make sure ignition is turned off.

When the ignition is turned back ON, check that no active or stored faults are logged in the ECU and that the ABS and ATC/ESC warning lamps are OFF. Figure 11.19 and Figure 11.20.

Fig. 11.19

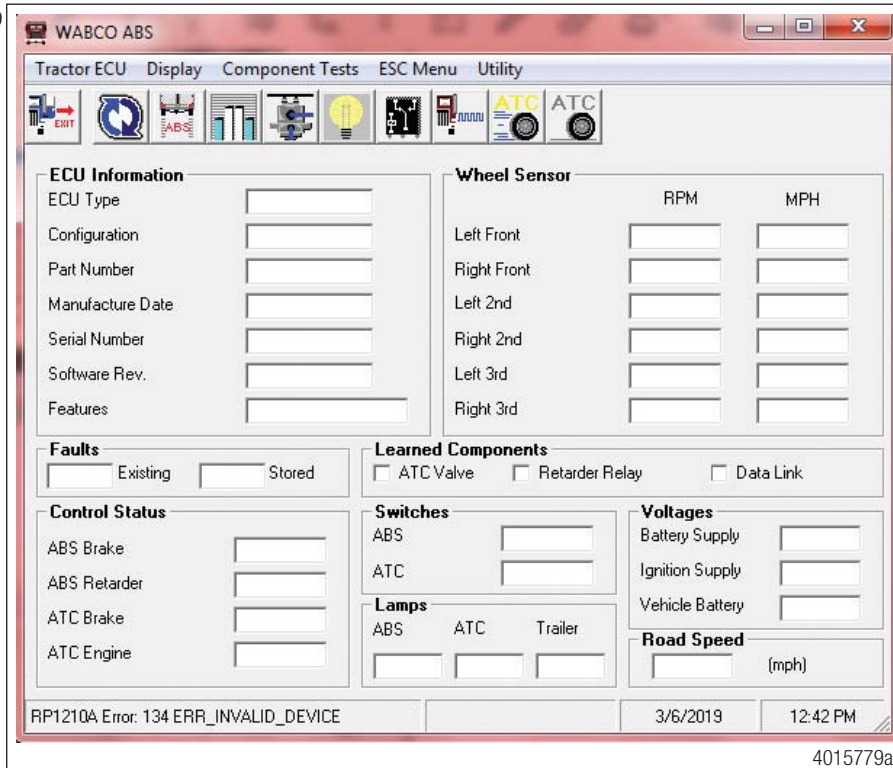


Fig. 11.20



The ESC EOL Initialization procedure is completed.



If ESC EOL initialization was not properly completed and/or ratios correctly saved, code SID 88 FMI 1 will be active. Follow the ESC initialization again and make sure each portion is successfully completed. Make sure ignition power down is completed for the ECU to successfully save data.



# 12 Appendix III

## 12.1 E8 ESC End of Line Calibration Procedure

This procedure is performed as part of the final assembly of the vehicle at the manufacturing site. Also, this procedure must be performed in the field by a trained technician if components are replaced such as the Steering Angle Sensor (SAS), the Electronic Stability Control (ESC) module or the ESC Electronic Control Unit (ECU). This calibration should also be performed when a major steering repair or replacement has taken place.

The process consists of two operations. The first one is the SAS Calibration while the vehicle is stationary, followed by the ESC Initialization while driving the vehicle. The status of the ESC End of Line (EOL) procedure can be verified using one of the following allowed faults.

- SAS not calibrated — SPN 1807, FMI 08
- ESC initialization required — SPN 520210 FMI 14

### CAUTION

Additional faults must not be active. Any other faults must be resolved before one of the main menu items is available.



To prevent incorrect activations, SAS Calibration and ESC Initialization must be done separately. It is necessary to perform the SAS calibration prior to the ESC initialization.

For any questions or assistance, please contact the WABCO Customer Care at Center at 855-228-3203 or visit [wabco-na.com](http://wabco-na.com) for further details.

### 12.1.1 SAS Calibration



The SAS Calibration must be done after a front wheel alignment has been performed.

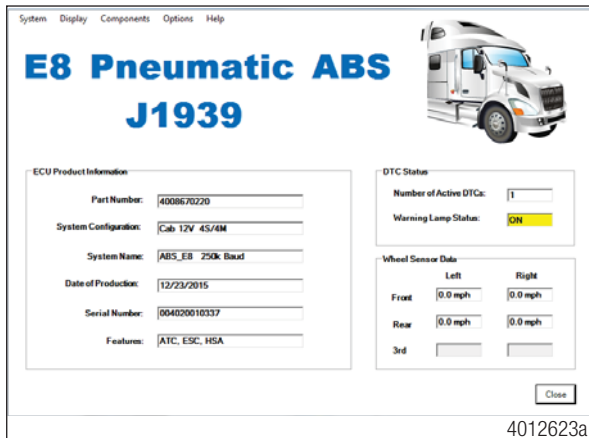
The E8 software version requires TOOLBOX™ Software version 12 or higher to communicate with the vehicle. Pneumatic ABS J1939 must be used to complete the end of line procedure.

In the Main Menu, select Pneumatic ABS (J1939), the ABS Main Screen will appear. Figure 12.1 and Figure 12.2.

Fig. 12.1



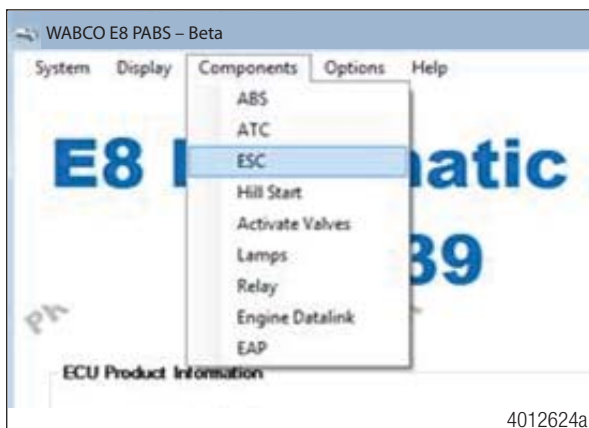
Fig. 12.2



To access the ESC EOL:

From the bar menu at the initial screen, click on the “Components” button. A drop-down menu will appear. Select the option “ESC.” Figure 12.3.

Fig. 12.3



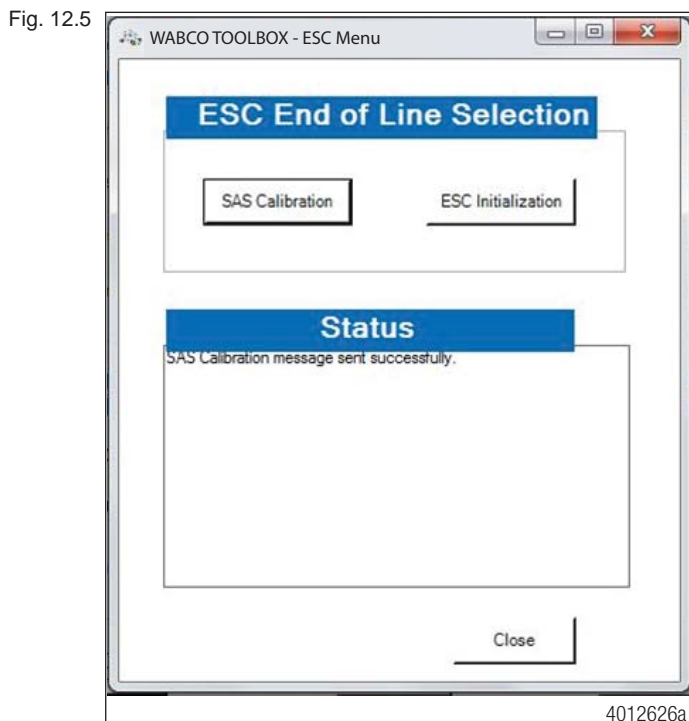
On the screen that appears, click the “ESC EOL” button. Figure 12.4.



**i** If SAS has NOT been replaced but vehicle has had an alignment performed or other steering components have been replaced, it is necessary to recalibrate SAS regardless of current calibration.

**i** The vehicle needs to be sitting still during SAS calibration.

To complete the SAS Calibration, position the steer axle tires straight ahead and click “SAS Calibration”. Upon successful calibration, the status box will display “SAS Calibration message sent successfully”.Figure 12.5.



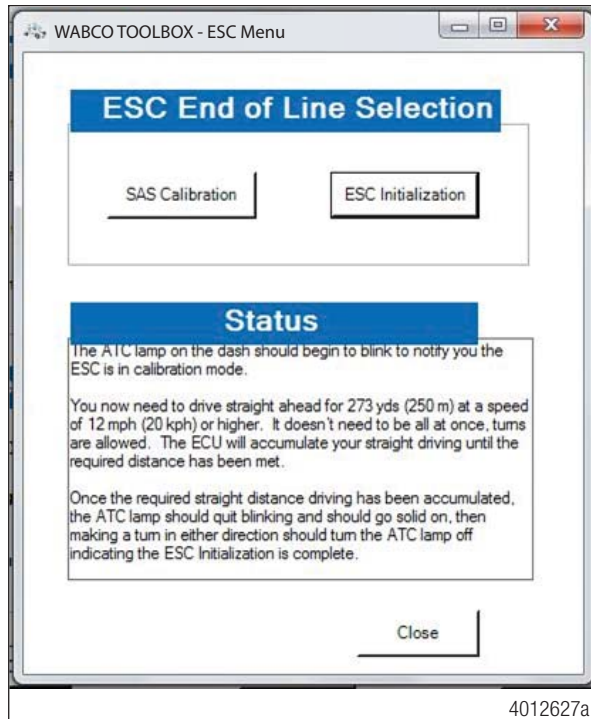
The SAS calibration is now completed. Click the “Close” button to close the screen.

If SAS calibration fails, recheck the SAS connection and verify SAS mounting. Cycle the ignition and retry SAS calibration again.

### ESC Initialization

Access the ESC EOL menu as in SAS calibration, but instead in the message box that appears, click the “ESC Initialization” button. Check the message box that appears. The ATC lamp will start blinking to inform driver ECU is in learning mode. Figure 12.6.

Fig. 12.6



Carefully follow the instructions that appear in the message box. Once the ESC initialization is started, the messages will automatically change as the requirements are met. **DO NOT** click the “continue” button again as this may cause the process to fail. The ESC Initialization procedure requires the vehicle to be driven.

The straight driving adjustment can be done in segments as the ECU will accumulate the information until the 273 yards is reached. Cornering and stopping is allowed as long as calibration is done within the same ignition cycle.

When the Straight Driving Adjustment is completed after ECU accumulated 273 yards of straight driving, the ATC lamp will stop blinking and will remain ON.

Once the straight driving portion of the calibration is completed, make a left or right turn to complete the initialization procedure. At this point the ATC lamp will turn off indicating the ESC initialization was successful.

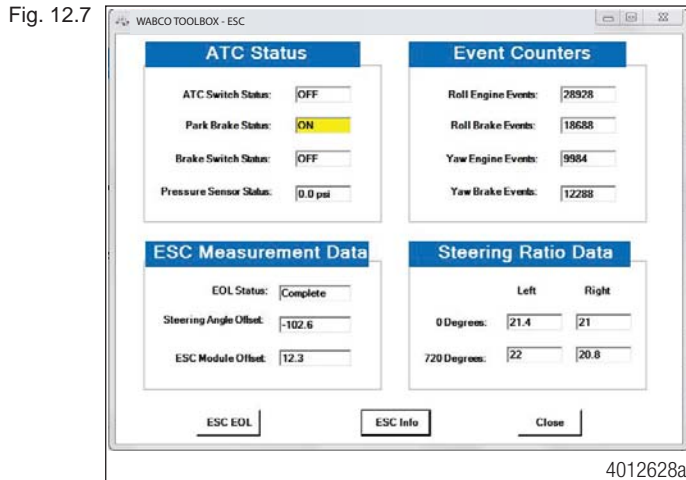
For the ECU to be able to save ratios and ESC EOL data, the ignition **MUST** be cycled. With the vehicle stopped, close window that appeared and cycle the ignition for around 10 seconds.



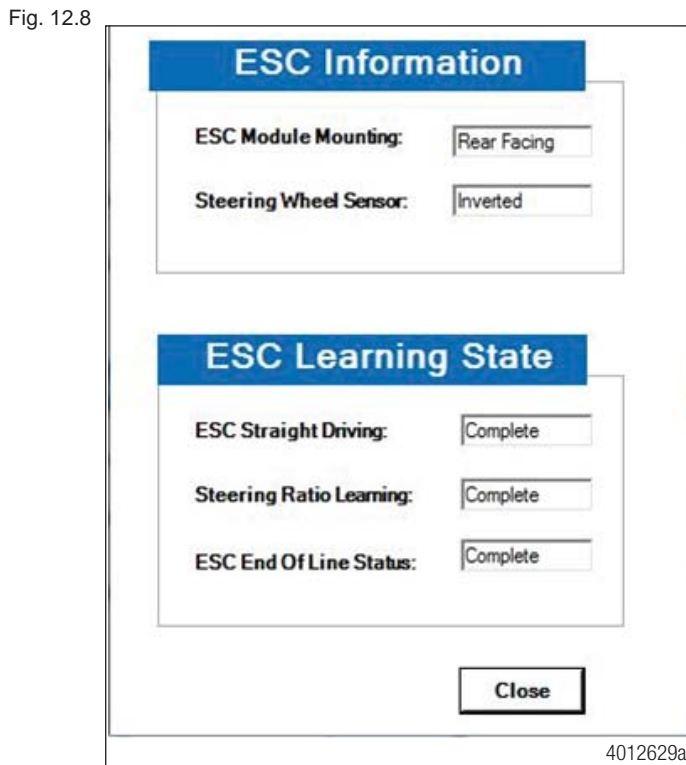
Power down cycle time and sequence will vary amongst vehicle manufacturers. Some vehicles might require the key to be removed from the ignition for ignition power to be completely turned off. Please follow the vehicle manufacturer procedure to make sure ignition is turned off

When the ignition is turned back ON, check that no active or stored faults are logged in the ECU and that the ABS and ATC/ESC warning lamps are OFF.

To check ESC system status, open the ESC menu and click the “ESC Info” button. Figure 12.7.



The ESC Information screen will display the ESC straight driving, Steering Ratio Learning, and ESC End of Line Status as “Complete”. Figure 12.8.



The ESC EOL Initialization procedure is completed. Click the “Close” button to close the screen.

**i** If ESC EOL initialization was not properly completed and/or ratios correctly saved, code SPN 520210 88 FMI 14 will be active. Follow the ESC initialization again and make sure each portion is successfully completed. Make sure ignition power down is completed for the ECU to successfully save data.

## 13 Appendix IV

### 13.1 Aftermarket Programming

Aftermarket programming is a method of servicing most pneumatic ABS ECUs. Instead of swapping one fully programmed ECU for another, programmable ECUs can be stocked at the point of service and programmed using a purchased configuration file. The process can be completed in the following steps.

1. Acquire a programmable replacement ECU from Meritor’s aftermarket distribution channel.
2. Install the replacement ECU into the vehicle.
3. Acquire a configuration file from <https://wabco.snapon.com>.
4. Load the configuration file into the ECU using WABCO’s TOOLBOX™ Aftermarket Programming application.



Aftermarket programming does not change the functionality of the ABS-based safety system as installed in the vehicle.

#### 13.1.1 Minimum Requirements for Aftermarket Programming

Before ordering a programmable ECU, ensure you meet all of the requirements to program the ECU on the vehicle.

1. Aftermarket programming requires J1939 communications. Any J1939 RP1210 diagnostic adapter such as the Nexiq USB-Link™ 2 can be used for programming.
2. Aftermarket programming requires a minimum version of TOOLBOX™ Software.

**Table D: Minimum Requirements**

ECU Type	Minimum TOOLBOX™ Software Version
E4 250 kbaud	11.5
E4 500 kbaud	12.2
E8 250 or 500 kbaud	12.2

3. Aftermarket programming requires a user account with [https:// wabco.snapon.com](https://wabco.snapon.com) to download configuration files.



Vehicles equipped with a 6-pin diagnostic connector likely do not have J1939 communication to the ABS ECU available. Users can obtain WABCO’s Bench Programming Unit 400 850 960 0 to program ECUs on the bench if J1939 communication is not available on the vehicle.



If you do not have the required diagnostic adapter or minimum version of TOOLBOX™ Software, these items can be purchased at <https://wabco.snapon.com>.

If you do not meet any of the above requirements, a fully programmed ECU can be purchased at additional cost from Meritor Aftermarket by contacting their customer care at 888-725-9355, Option #4.

If you meet all of the requirements, proceed with the following Aftermarket Programming procedures.

## 13.2 Aftermarket Programming Procedures

**Step 1: Acquire a programmable replacement ABS ECU from Meritor’s aftermarket distribution channel or refer to Meritor PartsXpress ([www.MeritorPartsXpress.com](http://www.MeritorPartsXpress.com)).** If you need help identifying the correct replacement programmable ECU, contact Meritor Aftermarket Customer Care at: USA: 888-725-9355, Canada: 800-387-3889.

Programmable ABS ECUs are clearly identified with a large orange sticker indicating it must be programmed and are also shipped with an instruction sheet explaining how to complete the service operation. Figure 13.1.

Fig. 13.1



**Step 2: Install the replacement ECU into the vehicle.**

The programmable ECU should be installed in the vehicle in the same manner and location as the ECU being replaced. Connect all electrical connectors.



Aftermarket programmable ECUs are backwards compatible with the ECUs they replace, so there should be no modifications required to either the mounting or electrical connections.

When the replacement ECU is installed, the ABS lamp will be lit due to an active DTC:

SID	SPN	FMI	Description
253	630	2	Calibration Memory – Wheel Parameter Incorrect



This DTC will clear after a configuration file has been successfully loaded into the ECU. The ABS lamp will remain on until the vehicle has been driven above 4 mph (6 km/h).

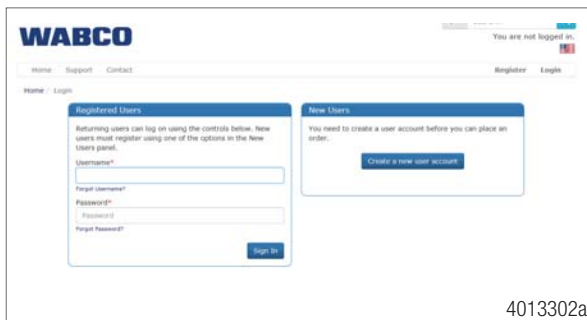
### Step 3: Acquire the required configuration file from <https://wabco.snapon.com>.

Begin by either creating an account or logging into an account created during a previous purchase from the site. Figure 13.2.



If you purchased TOOLBOX™ Software, then you already have an account and that account information should be used to log in.

Fig. 13.2



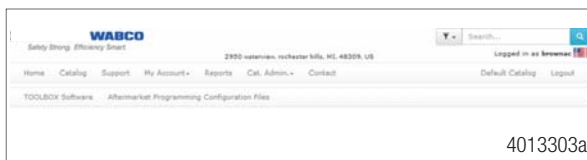
4013302a

Click the Aftermarket Programming Configuration Files button at the top of the screen.



If TOOLBOX™ Software is not available at the point of service, it can be purchased by clicking the TOOLBOX™ Software button. Figure 13.3.

Fig. 13.3

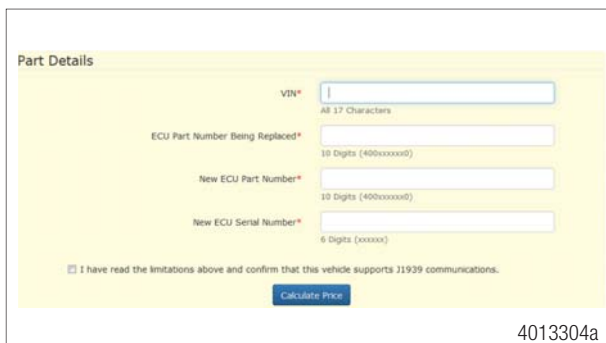


4013303a

Enter the part details for the vehicle being worked on and the part being replaced. Figure 13.4.

- The VIN must include all 17 characters.
  - The SmartTrac™ hydraulic ABS module part number being replaced must be entered.
  - The new programmable SmartTrac™ hydraulic ABS module part number must be entered.
- Figure 13.5.

Fig. 13.4



4013304a

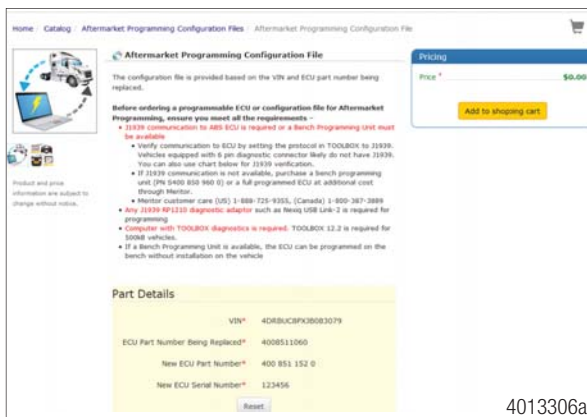


Fig. 13.5



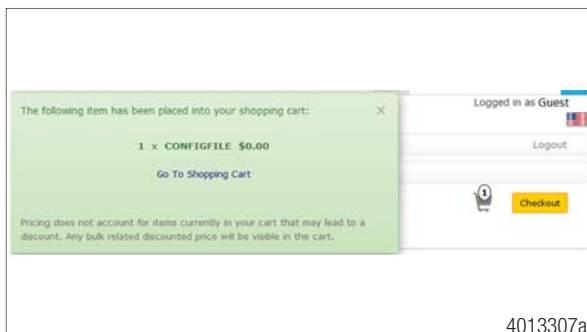
The next screen will show the configuration file details linked to the part number and VIN combination entered. Verify the VIN, part number and SmartTrac™ hydraulic ABS module functionality matches the SmartTrac™ hydraulic ABS module being replaced. If this information is correct, click the Add to shopping cart button. Figure 13.6.

Fig. 13.6



After the configuration file has been added to the shopping cart, the shopping cart will be displayed as a pop up window for a few seconds. Figure 13.7.

Fig. 13.7



Clicking on “Go To Shopping Cart” or “Check Out” symbol will take you to the contact details page that need to be filled out to process the order. Figure 13.8.

Fig. 13.8

4013308a

The first step in the checkout process is to verify contact information. The information will automatically populate based on login information; all fields can be edited. Click on “Bill To This Address” when contact info is filled out. Figure 13.9.

**i** Aftermarket Programming Configuration Files will not be charged and you will not be billed.

Fig. 13.9

4013309a

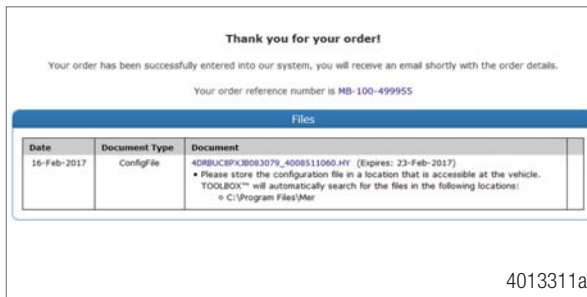
The final screen of the download process allows the details of the download to be reviewed before placing the order. If all of the information is correct, then check the box acknowledging the terms and conditions of the download and click Place Order. Figure 13.10.

Fig. 13.10

4013310a

The order will be processed and a link to download the configuration file will be displayed. Click the hyperlink to download the configuration file. Figure 13.11.

Fig. 13.11



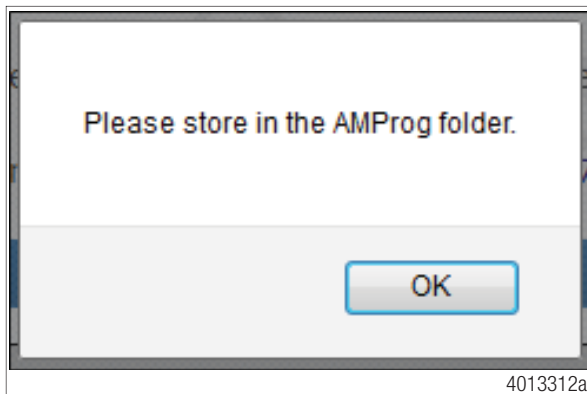
The file extension ".HY" is specifically for the SmartTrac™ hydraulic ABS module only. Ensure the file has this. No other file will be compatible.



**IMPORTANT: The configuration file will be available in your account for seven days from purchase. The configuration file must be downloaded to a computer within that time.**

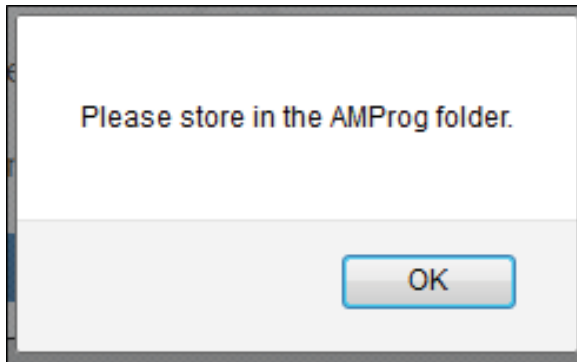
The following message will be displayed regarding recommended file storage location. Press OK to continue with saving the file. Figure 13.12.

Fig. 13.12



Save the configuration file to a location that can be accessed while connected to the vehicle. The aftermarket programming application will allow the file selection from any location in your computer. (Not just the AMProg Folder.) Figure 13.13.

Fig. 13.13



4013312a

**Step 4: Load the configuration file into the SmartTrac™ hydraulic ABS module using WABCO's TOOLBOX™ Software Aftermarket Programming application.**

Begin by verifying you have the latest version TOOLBOX™ Software. First locate the software version on the WABCO label on the SmartTrac™ hydraulic ABS module. An example of the cab ECU label is shown, and the ECU software version is circled. Figure 13.14.

Fig. 13.14



4015716a

Once you have verified you are using the correct version of TOOLBOX™ Software, connect to the vehicle using recommended J1939 RP1210 diagnostic adapter. Turn the ignition on, open TOOLBOX™, and click the aftermarket programming application to start programming the SmartTrac™ hydraulic ABS module. Fig. 13.15.



Wireless diagnostic adapters should not be used for aftermarket programming or any other WABCO programming operation.



It is recommended that aftermarket programming be completed with ignition on only. Do not cycle the key until the programming operation is complete. Verify the battery is fully charged prior to performing the programming operation; the vehicle should not be connected to a battery charger during programming. If the vehicle ignition is known to "time out" while using a key fob, use the vehicle key so the ignition will stay on during programming. Use WABCO's Bench Programming Unit and SmartTrac™ hydraulic EPI bench test cable for programming outside of the vehicle.



For complete instructions for using TOOLBOX™ Software, refer to the TOOLBOX™ Quick Start Guide: OM1618.

Fig. 13.15



A message will be displayed indicating that the SmartTrac™ hydraulic ABS module will be changed as a result of programming. Click “Yes” to continue with programming the SmartTrac™ hydraulic ABS module. Figure 13.16.


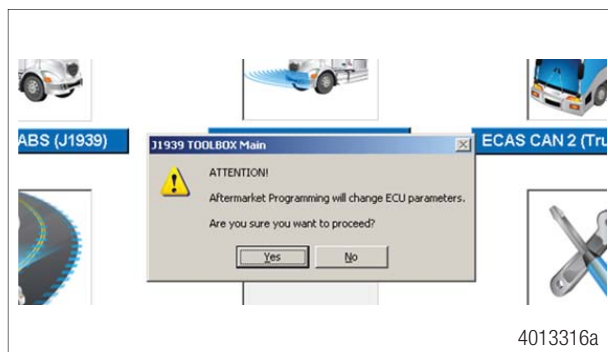
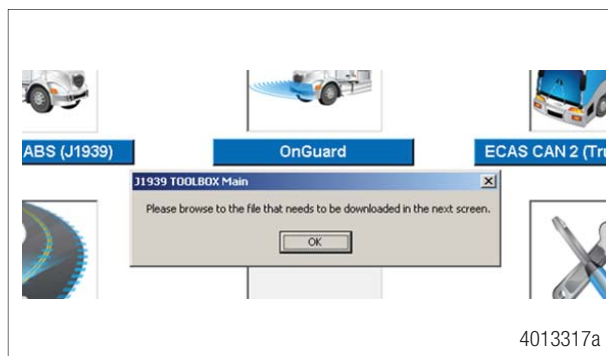
 Aftermarket Programming will change the SmartTrac™ hydraulic ABS module parameters.

Fig. 13.16



The Aftermarket Programming application will then locate the configuration file. Click OK to select the file. Figure 13.17.

Fig. 13.17



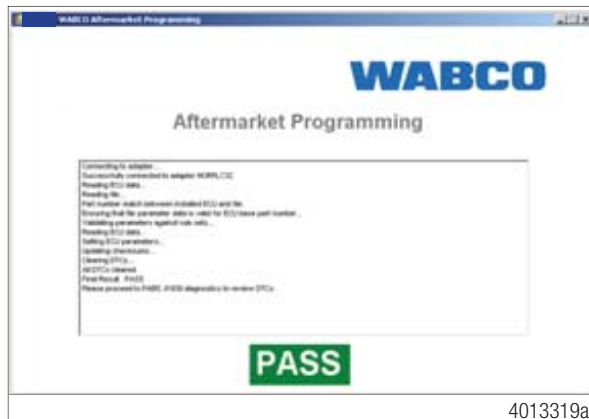
Use the file selection box to locate the configuration file that matches the part number and VIN being serviced. Select the file by clicking on it, and then click Open. Figure 13.18.

Fig. 13.18



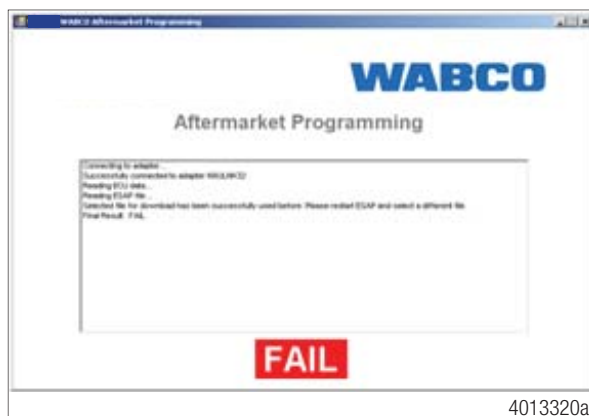
The Aftermarket Programming application will automatically run from this point. The programming operation progress will be displayed in the dialogue box. Once the SmartTrac™ hydraulic ABS module programming is successfully completed, a green PASS indicator will appear at the bottom of the aftermarket programming application window. Figure 13.19.

Fig. 13.19



If the programming operation fails for any reason, a red FAIL indicator will appear at the bottom of the aftermarket programming application window. Within the text box, an error code will be displayed with instructions. If the programming operation cannot be completed, record the error code and contact the WABCO Customer Care Center at 855-228-3203. Figure 13.20.

Fig. 13.20





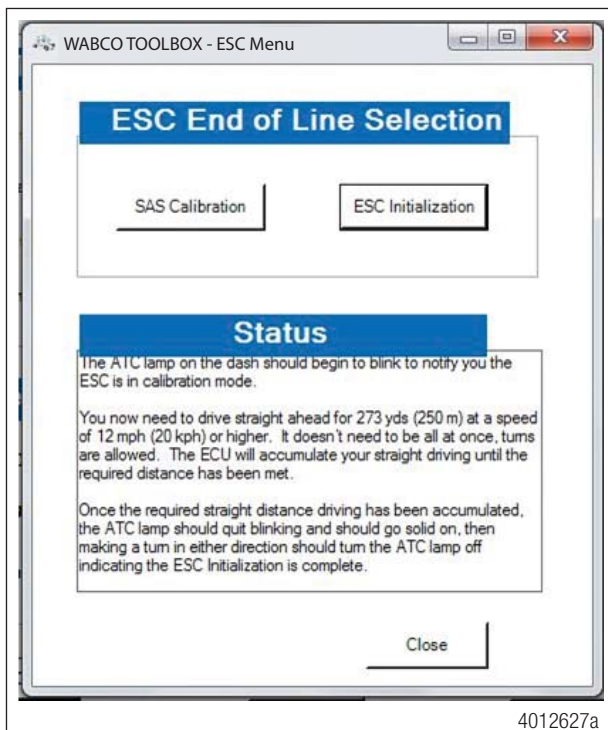
ESC ECUs will require the ESC End of Line procedure to be completed following ECU replacement.

## ESC Initialization

Access the ESC EOL menu as in SAS calibration, but instead in the message box that appears, click the “ESC Initialization” button.

Check the message box that appears. The ATC lamp will start blinking to inform driver ECU is in learning mode. Figure 13.21.

Fig. 13.21



Carefully follow the instructions that appear in the message box. Once the ESC initialization is started, the messages will automatically change as the requirements are met. **DO NOT** click the “continue” button again as this may cause the process to fail. The ESC Initialization procedure requires the vehicle to be driven.

The straight driving adjustment can be done in segments as the ECU will accumulate the information until the 273 yards is reached. Cornering and stopping is allowed as long as calibration is done within the same ignition cycle.

When the Straight Driving Adjustment is completed after ECU accumulated 273 yards of straight driving, the ATC lamp will stop blinking and will remain ON.

Once the straight driving portion of the calibration is completed, make a left or right turn to complete the initialization procedure. At this point the ATC lamp will turn off indicating the ESC initialization was successful.

For the ECU to be able to save ratios and ESC EOL data, the ignition **MUST** be cycled. With the vehicle stopped, close window that appeared and cycle the ignition for around 10 seconds.



Power down cycle time and sequence will vary amongst vehicle manufacturers. Some vehicles might require the key to be removed from the ignition for ignition power to be completely turned off. Please follow the vehicle manufacturer procedure to make sure ignition is turned off.

When the ignition is turned back ON, check that no active or stored faults are logged in the ECU and that the ABS and ATC/ESC warning lamps are OFF.

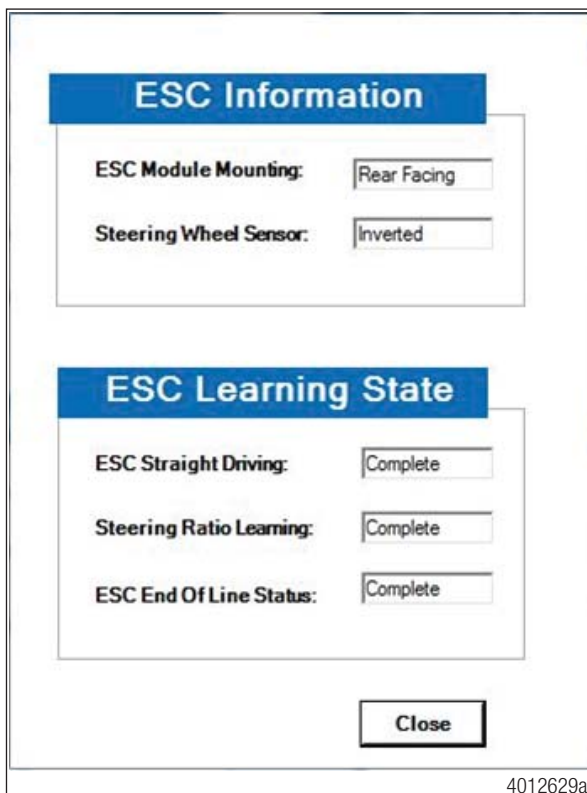
To check ESC system status, open the ESC menu and click the “ESC Info” button. Figure 13.22.

Fig. 13.22



The ESC Information screen will display the ESC straight driving, Steering Ratio Learning, and ESC End of Line Status as “Complete”. Figure 13.23.

Fig. 13.23





The ESC EOL Initialization procedure is completed. Click the “Close” button to close the screen.



If ESC EOL initialization was not properly completed and/or ratios correctly saved, code SPN 520210 88 FMI 14 will be active. Follow the ESC initialization again and make sure each portion is successfully completed. Make sure ignition power down is completed for the ECU to successfully save data.

## 13.3 Aftermarket Programming Failure Codes List

Fig. 13.24

SID	SPN	FMI	Warning Light	Programming Error Code	Message Displayed	Description/Action
253	630	2	ABS WL	None	None	This DTC is active for all programmable ECUs that have not been programmed with a configuration file. Completion of the programming operation will clear this DTC. If this code is active for a non-programmable ECU, refer to the SPN, SID, FMI Fault Codes section in this manual.
253	630	2	ABS WL	B1	Unable to connect to adapter [Adapter Name] (Error: B1). Please exit this window, cycle power, and try again. If the problem persists, please contact WABCO North America Customer Care at 855-228-3203.	The diagnostic adapter selection does not match the selection in TOOLBOX™ Software or the diagnostic adapter is not capable of J1939 communications. Return to the TOOLBOX™ Software main screen. Select Utilities --> Adapter Selection. Select the diagnostic adapter being used from the list of options.
253	630	2	ABS WL	B2	Unable to start diagnostic session with ECU (Error: B2). Please exit this window, cycle power and try again. If the problem persists, please contact WABCO North America Customer Care at 855-228-3203.	This failure may occur if communication with the ECU is interrupted during the configuration session. Close the TOOLBOX™ Software, reopen it and restart the aftermarket programming application. If the problem persists, repeat with key on only (Engine Off).  This failure will also occur when one or more of the following are not connected: Power, Ground, J1939 CAN High, or J1939 CAN Low. Check for continuity.
253	630	2	ABS WL	B3	Unable to read ECU Production Data (Error: B3). Please exit this window, cycle power and try again. If the problem persists, please contact WABCO North America Customer Care at 855-228-3203.	This failure may occur if communication with the ECU is interrupted during the configuration session. Close the TOOLBOX™ Software, reopen it and restart the aftermarket programming application. If the problem persists, repeat with key on only (Engine Off).  This failure will also occur when one or more of the following are not connected: Power, Ground, J1939 CAN High, or J1939 CAN Low. Check for continuity.
253	630	2	ABS WL	B4	Unable to read ECU Component ID (Error: B4). Please exit this window, cycle power and try again. If the problem persists, please contact WABCO North America Customer Care at 855-228-3203.	This failure may occur if communication with the ECU is interrupted during the configuration session. Close the TOOLBOX™ Software, reopen it and restart the aftermarket programming application. If the problem persists, repeat with key on only (Engine Off).  This failure will also occur when one or more of the following are not connected: Power, Ground, J1939 CAN High, or J1939 CAN Low. Check for continuity.
253	630	2	ABS WL	B5	Aftermarket programming configuration file for download not found (Error: B5).	This error will occur if the configuration file is moved or changed during a configuration session. Close the TOOLBOX™ Software, reopen it, and restart the aftermarket programming application. If the problem persists, repeat with key on only (Engine Off).
253	630	2	ABS WL	B6	Error reading the Aftermarket Programming configuration file (Error: B6).	This failure may occur if communication with the ECU is interrupted during the configuration session. Close the TOOLBOX™ Software, reopen it and restart the aftermarket programming application. If the problem persists, repeat with key on only (Engine Off).  This failure will also occur when one or more of the following are not connected: Power, Ground, J1939 CAN High, or J1939 CAN Low. Check for continuity.
253	630	2	ABS WL	B7	Selected file for download has been successfully used before. Please restart Aftermarket Programming and select a different file (Error: B7).	This failure will occur when a user tries to use a configuration file that has already been used to successfully configure an ECU. Purchase a new configuration file at <a href="https://wabco-na.snapon.com">https://wabco-na.snapon.com</a> .

4012092a

Fig. 13.25

SID	SPN	FMI	Warning Light	Programming Error Code	Message Displayed	Description/Action
253	630	2	ABS WL	B8	Module of the Aftermarket Programming file for download is incorrect for this application (Error: B8). Ensure that the Aftermarket Programming file extension was not renamed. Please exit this window and select Aftermarket Programming to try again.	This error will occur if the configuration file is moved or changed during a configuration session. Close TOOLBOX™ Software, reopen it and restart the aftermarket programming application. If the problem persists, repeat with key on only (Engine Off).
253	630	2	ABS WL	B9	Part number of installed ECU [part number] does not match part number of Aftermarket Programming configuration file (Error: B9). Please contact Meritor OnTrac™ Customer Call Center at 866-On Trac1 (668-7221).	This failure will occur when the part number in the configuration file does not match the aftermarket programmable ECU part number. Verify that the aftermarket programmable replacement ECU is correct for the ECU previously installed on the vehicle.
253	630	2	ABS WL	B10	This Aftermarket Programming configuration file does not work for this vehicle (Error: B10). Please contact WABCO North America Customer Care at 855-228-3203.	This failure will only occur when the VIN for the configuration file does not match the actual VIN of the vehicle being serviced. Verify that the VIN used to purchase the configuration file matches that of the vehicle the aftermarket programmable replacement ECU is being installed in/programmed on.
253	630	2	ABS WL	B11	Invalid ECU part number [part number] for programming (Error: B11).	This failure will occur when attempting to configure an ECU that does not require aftermarket programming. Verify the ECU does not require programming and refer to the SPN SID FMI Fault Codes section in this manual.
253	630	2	ABS WL	B12	Unable to read parameters from ECU (Error: B12). Please exit this window, cycle power and try again. If the problem persists, please contact WABCO North America Customer Care at 855-228-3203.	This failure may occur if communication with the ECU is interrupted during the configuration session. Close the TOOLBOX™ Software, reopen it and restart the aftermarket programming application. If the problem persists, repeat with key on only (Engine Off).  This failure will also occur when one or more of the following are not connected: Power, Ground, J1939 CAN High, or J1939 CAN Low. Check for continuity.
253	630	2	ABS WL	B13	Unable to gain security access to ECU (Error: B13). Please exit this window, cycle power, and try again. If the problem persists, please contact WABCO North America Customer Care at 855-228-3203.	This failure may occur if communication with the ECU is interrupted during the configuration session. Close the TOOLBOX™ Software, reopen it and restart the aftermarket programming application. If the problem persists, repeat with key on only (Engine Off).  This failure will also occur when one or more of the following are not connected: Power, Ground, J1939 CAN High, or J1939 CAN Low. Check for continuity.
253	630	2	ABS WL	B14	Unable to write VIN to the ECU (Error: B14). Please exit this window, cycle power and try again. If problem persists, please contact WABCO North America Customer Care at 855-228-3203.	This failure may occur if communication with the ECU is interrupted during the configuration session. Close the TOOLBOX™ Software, reopen it and restart the aftermarket programming application. If the problem persists, repeat with key on only (Engine Off).  This failure will also occur when one or more of the following are not connected: Power, Ground, J1939 CAN High, or J1939 CAN Low. Check for continuity.

4012093a

Fig. 13.26

SID	SPN	FMI	Warning Light	Programming Error Code	Message Displayed	Description/Action
253	630	2	ABS WL	B15	Unable to write checksum to ECU: Block [block information] (Error: B15). Please exit this window, cycle power and try again. If the problem persists, please contact WABCO North America Customer Care at 855-228-3203.	This failure may occur if communication with the ECU is interrupted during the configuration session. Close the TOOLBOX™ Software, reopen it, and restart the aftermarket programming application. If the problem persists, repeat with key on only (Engine Off).  This failure will also occur when one or more of the following are not connected: Power, Ground, J1939 CAN High, or J1939 CAN Low. Check for continuity.
253	630	2	ABS WL	B16	Communication Error (Error: B16). Please exit this window, cycle power, and try again. If the problem persists, please contact WABCO North America Customer Care at 855-228-3203.	This failure may occur if communication with the ECU is interrupted during the configuration session. Close the TOOLBOX™ Software, reopen it, and restart the aftermarket programming application. If the problem persists, repeat with key on only (Engine Off).  This failure will also occur when one or more of the following are not connected: Power, Ground, J1939 CAN High, or J1939 CAN Low. Check for continuity.
253	630	2	ABS WL	B17	Parameter Incompatibility (Error: B17). Please contact WABCO North America Customer Care at 855-228-3203.	Close the TOOLBOX™ Software, reopen it and restart the aftermarket programming application. If the problem persists, repeat with key on only (Engine Off).
253	630	2	ABS WL	B18	Unable to read memory address before setting parameter (Error: B18). Please exit this window, cycle power and try again. If the problem persists, please contact WABCO North America Customer Care at 855-228-3203.	This failure may occur if communication with the ECU is interrupted during the configuration session. Close the TOOLBOX™ Software, reopen it and restart the aftermarket programming application. If the problem persists, repeat with key on only (Engine Off).  This failure will also occur when one or more of the following are not connected: Power, Ground, J1939 CAN High, or J1939 CAN Low. Check for continuity.
253	630	2	ABS WL	B19	VCP program error: ByteToChange for [parameter information] neither 0 nor 1 (Error: B19). Please exit this window, cycle power and try again. If the problem persists, please contact WABCO North America Customer Care at 855-228-3203.	This failure may occur if communication with the ECU is interrupted during the configuration session. Close the TOOLBOX™ Software, reopen it and restart the aftermarket programming application. If the problem persists, repeat with key on only (Engine Off).  This failure will also occur when one or more of the following are not connected: Power, Ground, J1939 CAN High, or J1939 CAN Low. Check for continuity.
253	630	2	ABS WL	B20	Unable to write parameter: [parameter information] (Error: B20). Please exit this window, cycle power, and try again. If the problem persists, please contact WABCO North America Customer Care at 855-228-3203.	This failure may occur if communication with the ECU is interrupted during the configuration session. Close the TOOLBOX™ Software, reopen it and restart the aftermarket programming application. If the problem persists, repeat with key on only (Engine Off).  This failure will also occur when one or more of the following are not connected: Power, Ground, J1939 CAN High, or J1939 CAN Low. Check for continuity.
253	630	2	ABS WL	B21	Error while trying to set parameters (Error: B21). Please exit this window, cycle power and try again. If the problem persists, please contact WABCO North America Customer Care at 855-228-3203.	This failure may occur if communication with the ECU is interrupted during the configuration session. Close the TOOLBOX™ Software, reopen it and restart the aftermarket programming application. If the problem persists, repeat with key on only (Engine Off).  This failure will also occur when one or more of the following are not connected: Power, Ground, J1939 CAN High, or J1939 CAN Low. Check for continuity.

4012094a

Fig. 13.27

SID	SPN	FMI	Warning Light	Programming Error Code	Message Displayed	Description/Action
253	630	2	ABS WL	A1	Error parsing the Aftermarket Programming configuration file (Error: A1).	Close the TOOLBOX™ Software, reopen it and restart the aftermarket programming application. If the problem persists, repeat with key on only (Engine Off).
253	630	2	ABS WL	A2	No parameters were found in the Aftermarket Programming configuration file (Error: A2).	Close the TOOLBOX™ Software, reopen it and restart the aftermarket programming application. If the problem persists, repeat with key on only (Engine Off).
253	630	2	ABS WL	A3	Part number is missing from the Aftermarket Programming configuration file (Error: A4). Please contact WABCO North America Customer Care at 855-228-3203.	Close the TOOLBOX™ Software, reopen it and restart the aftermarket programming application. If the problem persists, repeat with key on only (Engine Off).
253	630	2	ABS WL	A4	VIN not found in the Aftermarket Programming configuration file (Error: A4). Please contact WABCO North America Customer Care at 855-228-3203.	Close the TOOLBOX™ Software, reopen it and restart the aftermarket programming application. If the problem persists, repeat with key on only (Engine Off).
253	630	2	ABS WL	C1	Mismatch found between installed ECU and the configuration file (Error: C1).	Close the TOOLBOX™ Software, reopen it and restart the aftermarket programming application. If the problem persists, repeat with key on only (Engine Off).
253	630	2	ABS WL	C2	[Parameter] Incorrect for installed ECU part number (Error: C2).	Close the TOOLBOX™ Software, reopen it and restart the aftermarket programming application. If the problem persists, repeat with key on only (Engine Off).

4012095a



## About WABCO

WABCO (NYSE: WBC) is the leading global supplier of braking control systems and other advanced technologies that improve the safety, efficiency and connectivity of commercial vehicles. Originating from the Westinghouse Air Brake Company founded nearly 150 years ago, WABCO is powerfully “Mobilizing Vehicle Intelligence” to support the increasingly autonomous, connected and electric future of the commercial vehicle industry. WABCO continues to pioneer innovations to address key technology milestones in autonomous mobility and apply its extensive expertise to integrate the complex control and fail-safe systems required to efficiently and safely govern vehicle dynamics at every stage of a vehicle’s journey – on the highway, in the city and at the depot. Today, leading truck, bus and trailer brands worldwide rely on WABCO’s differentiating technologies. Powered by its vision for accident-free driving and greener transportation solutions, WABCO is also at the forefront of advanced fleet management systems and digital services that contribute to commercial fleet efficiency. In 2018, WABCO reported sales of over \$3.8 billion and has more than 16,000 employees in 40 countries. For more information, visit [www.wabco-na.com](http://www.wabco-na.com).